

STANDING DATA FOR MSATS

Prepared by: AEMO MARKETS

Version: 5.89

Effective date: [15 November 2024](#)TBA

Status: [Final](#)Draft

Approved for distribution and use by:

Approved by: ~~Chin-Chan~~[Mark Katsikandarakis](#)

Title: Group Manager, Market Management

Date: [13 November 2024](#)

aemo.com.au

New South Wales | Queensland | South Australia | Victoria | Australian Capital Territory | Tasmania | Western Australia

Australian Energy Market Operator Ltd ABN 94 072 010 327

Contents

Current version release details	5
1. Introduction	6
1.1. Purpose and scope	6
1.2. Definitions and interpretation	6
1.3. Related documents	6
2. BACKGROUND	6
3. Conventions used within this document	7
3.1. Column Headed: Standing Data Required	7
3.2. NMI's Affected	8
4. CATS_METER_REGISTER	9
4.1. Field Definitions	9
4.2. Cross Reference of Browser and aseXML Data Elements	15
4.3. Field value examples	18
5. CATS_DLF_CODES	20
5.1. Field Definitions	20
5.2. Cross Reference of Browser and aseXML Data Elements	21
5.3 Field value examples	23
6. CATS_EMB_NET_ID_CODES	23
6.1. Field Definitions	23
6.2. Cross Reference of Browser and aseXML Data Elements	25
6.3. Field value examples	26
7. CATS_NMI_DATA	27
7.1. Field Definitions	27
7.2. Cross Reference of Browser and aseXML Data Elements	32
7.3. Field value examples	36
8. CATS_NMI_DATA_STREAM	38
8.1. Field Definitions	38
8.2. Cross Reference of Browser and aseXML Data Elements	40
8.3. Field value examples	41
9. CATS_Register_identifier	43
9.1. Field Definitions	43
9.2. Cross Reference of Browser and aseXML Data Elements	46
9.3. Field value examples	47
10. CATS_NMI_PARTICIPANT_RELATIONS	49
10.1. Field Definitions	49
10.2. Cross Reference of Browser and aseXML Data Elements	50
11. Reference tables	52

12. Use of NMI suffix to populate CATS_REGISTER_IDENTIFIER	55
12.1. Historical Information and Guideline only	57
13. Assignment of data – ACCUMULATION meters	58
13.1. Single Meter, no controlled load	58
13.2. Two Single Element Meters, no controlled load	5859
13.3. Two Single Element Meters, one with controlled load	59
13.4. One Meter with Two Registers, one measuring a controlled load	5960
13.5. Single Multi-function Meter	60
13.6. Two meters, three registers. One register measures a controlled load	61
14. Assignment of data – interval meters	61
14.1. One meter	61
14.2. Import/Export meter	62
14.3. One meter: multiple registers	62
14.4. One meter: Twin Measurement Elements	63
14.5. NCONUML and UMCP	64
15. Assignments of data – sample meters	64
15.1. Multifunction Sample Meter	6465
16. Data type conventions	65
Version release history	67

Tables

Table 1	MSATS Master Tables.....	6
Table 2	Explanation of Standing Data Requirements.....	7
Table 3	CATS_METER_REGISTER – Field Definitions.....	9
Table 4	CATS_Meter_Register – Browser Cross Reference	15
Table 5	MSATS_Meter_Register - Example	18
Table 6	CATS_DLF_CODES – Field Definitions.....	20
Table 7	CATS_DLF_Codes - Browser Cross Reference	22
Table 8	CATS_DLF_Codes - Example	23
Table 9	CATS_EMB_NET_ID_CODES – Field Definitions	24
Table 10	CATS_Emb_Net_ID_Codes - Browser Cross Reference.....	25
Table 11	CATS_Emb_Net_ID_Codes - Example.....	26
Table 12	CATS_NMI_DATA – Field Definitions.....	27
Table 13	CATS_NMI_Data	32
Table 14	CATS_NMI_Data Field value examples.....	36
Table 15	CATS_NMI_DATA_STREAM – Field Definitions	39
Table 16	CATS_NMI_DATA_STREAM- Browser cross reference.....	41
Table 17	CATS_NMI_Data_Stream – Examples.....	42
Table 18	CATS_REGISTER_IDENTIFIER – Field Definitions	43
Table 19	CATS_Register_Identifier - Browser Cross Reference	46
Table 20	CATS_Register_Identifier - Example	48

Table 21	CATS_NMI_PARTICIPANT_RELATIONS – Field Definitions.....	49
Table 22	CATS_NMI_Participant_Relations - Browser Cross Reference	50
Table 23	- Valid Aggregate Codes	52
Table 24	- Valid Consumption Type Codes	52
Table 25	- Valid Datastream Type Codes	53
Table 26	- Valid Profile Codes	53
Table 27	Valid Transformer Fields values.....	53
Table 28	Valid Meter Use Codes.....	5354
Table 29	Valid Time of Day Codes.....	54
Table 30	Valid Controlled Load Codes.....	54
Table 31	Valid Test Result Codes	54
Table 32	Valid Transformer Test Values	54
Table 33	Valid Shared Isolation Point Flag Values	5455
Table 34	Example CATS_NMI_DATA_STREAM	58
Table 35	Example CATS_REGISTER_IDENTIFIER.....	5859
Table 36	Example CATS_NMI_DATA_STREAM	59
Table 37	Example CATS_REGISTER_IDENTIFIER	59
Table 38	Example CATS_NMI_DATA_STREAM	59
Table 39	Example CATS_REGISTER_IDENTIFIER	59
Table 40	Example CATS_NMI_DATA_STREAM	60
Table 41	Example CATS_REGISTER_IDENTIFIER	60
Table 42	Example CATS_NMI_DATA_STREAM	60
Table 43	Example CATS_REGISTER_IDENTIFIER	6064
Table 44	Example CATS_NMI_DATA_STREAM	61
Table 45	Example CATS_REGISTER_IDENTIFIER	61
Table 46	Example CATS_NMI_DATA_STREAM	61
Table 47	Example CATS_REGISTER_IDENTIFIER.....	6162
Table 48	Example CATS_NMI_DATA_STREAM	62
Table 49	Example CATS_REGISTER_IDENTIFIER	62
Table 50	Example CATS_NMI_DATA_STREAM	62
Table 51	Example CATS_NMI_DATA_STREAM	63
Table 52	Example CATS_REGISTER_IDENTIFIER.....	6364
Table 53	Example CATS_NMI_DATA_STREAM	64
Table 54	Example CATS_REGISTER_IDENTIFIER	64
Table 55	Example CATS_NMI_DATA_STREAM	65
Table 56	Example CATS_REGISTER_IDENTIFIER.....	65
Table 57	BROWSER FORMATS.....	65

Current version release details

Version	Effective date	Summary of changes
5.715.9	2 June 2024 15 November 2024	Consolidated versions 5.63 and 5.7 of the Standing Data Document for the Retail Electricity Market Procedures June 2024 Consolidation Consultation Updating Standing Data document as part of the CATS and WIGS procedures amalgamation.

Note: There is a full version history at the end of this document.

1. Introduction

1.1. Purpose and scope

This document details the data requirements for the various data elements comprising the CATS Standing Data stored for each *NMI*, together with relevant examples and definitions.

This document forms part of each of the Retail Electricity Market Procedures and will be amended when another Retail Electricity Market Procedure requires amendment. The consultation process applicable to the relevant Retail Electricity Market Procedure will also apply to the necessary amendments to this document.

1.2. Definitions and interpretation

The Retail Electricity Market Procedures – Glossary and Framework:

- a) is incorporated into and forms part of this document; and
- b) should be read with this document.

1.3. Related documents

Title	Location
Retail Electricity Market Procedures – Glossary and Framework	https://www.aemo.com.au/Electricity/National-Electricity-Market-NEM/Retail-and-metering
CATS-MSATS Procedures Principles and Obligations for all Connection Points	http://www.aemo.com.au/Electricity/National-Electricity-Market-NEM/Retail-and-metering/Market-Settlement-and-Transfer-Solutions
WIGS Procedures	http://www.aemo.com.au/Electricity/National-Electricity-Market-NEM/Retail-and-metering/Market-Settlement-and-Transfer-Solutions
MDM Procedures	http://www.aemo.com.au/Electricity/National-Electricity-Market-NEM/Retail-and-metering/Market-Settlement-and-Transfer-Solutions
MSATS CATS history Model	http://www.aemo.com.au/Electricity/National-Electricity-Market-NEM/Retail-and-metering/Market-Settlement-and-Transfer-Solutions
MSATS guides	http://www.aemo.com.au/Electricity/National-Electricity-Market-NEM/Retail-and-metering/Market-Settlement-and-Transfer-Solutions

2. BACKGROUND

The five MSATS master tables contain the standing data stored for each *NMI*. They are the following:

Table 1 MSATS Master Tables

Table	Summary of Contents
CATS_NMI_DATA	Address, TNI Code, DLF Code, aggregate flag, embedded network names, Jurisdiction, NMI status code, etc.
CATS_NMI_PARTICIPANT_RELATIONS	Roles and associated Participants. Separate records are maintained for each Role/Participant relationship.
CATS_NMI_DATA_STREAM	Suffix, ADL Code, Profile Name, Datastream type and datastream status of each MDM Datastream.
CATS_METER_REGISTER	Meter Serial ID, meter type, meter manufacturer, test results, etc.

Table	Summary of Contents
CATS_REGISTER_IDENTIFIER	Meter Serial ID, Network Tariff Code, unit of measure etc.

For a *NMI* to be capable of being used in MSATS, it must have the following minimum set of data:

- At least one record on the CATS_NMI_DATA table; and
- At least eight records on the CATS_NMI_PARTICIPANT_RELATIONS table, one for each of the mandatory roles (ROLR, LNSP, LR, RP, FRMP, MDP, MPC and MPB).

It will also normally have:

- At least one record on each of the CATS_METER_REGISTER and CATS_REGISTER_IDENTIFIER (there should be at least one record for each *meter* and register associated with the *NMI*) tables.

NMIs may or may not have:

- Records on the CATS_NMI_DATA_STREAM table. If *metering data* is to be submitted to MDM there must be at least one valid record on this table.

Every time a change is made to any of the data in any of these tables, the old records are made inactive and new records are created, thus ensuring that there is a complete history of all changes.

3. Conventions used within this document

The format of the data fields in the ‘Browser Format Column’ column of Tables is as defined in Section 16.

The following information defines the coded entries in columns used in Tables 3, 6, 9, 12, 15, 18 and 21.

3.1. Column Headed: Standing Data Required

The column indicates the requirement to provide this data to MSATS.

Table 2 Explanation of Standing Data Requirements

Requirement	Description
MANDATORY	Transfer, Validation or processing cannot proceed without this data.
REQUIRED	This data must be provided if this information is available.
OPTIONAL	This data is not required but will be accepted if delivered.
Address Option 1	AEMO’s preferred address option. If the applicable fields labelled “Address Option 1” cannot be provided, “Address Option 2” is MANDATORY.
Address Option 2	AEMO’s non-preferred address option. If Address Option 1 is provided, these fields are not to be supplied.

3.2. NMI's Affected

Data must be provided for every *NMI* in MSATS. The *NMI's* that must be registered in MSATS are:

- All *connection points* where a *transmission network* connects to another *transmission network*.
- All *connection points* where a *transmission network* connects to a *distribution network*, i.e. *bulk supply connection points*.
- All *transmission network connection points* where *energy* is directly purchased from the *spot market* by a *Market Customer*, i.e. *wholesale connection points*.
- All *distribution network connection points* where *energy* is directly purchased from the *spot market* by a *Market Customer*.
- All *connection points* on a *distribution network* that connect that *distribution network* to an adjacent *distribution network* (other than an *embedded network*), i.e. *cross boundary connection points*.
- Sample meters as required by Metrology Procedures Part A to calculate CLP for participating jurisdictions.
- All *connection points* associated with a registered *integrated resource system* that is connected to the *transmission network*, i.e. *transmission-connected integrated resource system*.
- All *connection points* associated with a registered *integrated resource system* that is connected to the *distribution network*, i.e. *distribution-connected integrated resource system*.
- All *connection points* associated with a *generating unit classified by a Market Generator* connected to a registered network other than a *transmission network* or *embedded network*, i.e., *distribution-connected generating system*
- All *connection points* associated with a *generating unit classified by a Market Generator* connected to a *transmission network*, i.e. *transmission-connected generating system*.
- All *connection points* that are *small resource connection points* that are not a *micro DER connection*, i.e. *non-registered connection points*.
- All *type 7 loads*.
- All *non-contestable unmetered loads*.
- All *distribution network connection points* where there is a *market connection point*.
- All *child connection points*.

4. CATS_METER_REGISTER

4.1. Field Definitions

The CATS_Meter_Register table is a NMI master table containing data that is stored at the Meter Register level. Information stored at this level includes the NSRD. It is updated whenever a Change Request containing inbound Meter Register data is completed.

Note: References to 'LNSP' include the ENM for *child connection points*.

Table 3 CATS_METER_REGISTER – Field Definitions

Data Element Name	Description	Standing Data Required	Party to Provide
CurrentTransformerLocation	A free text field to indicate the location of the current transformer at the site.	REQUIRED NOT USED for NCONUML, BULK, XBOUNDRY and INTERCON	MPB
CurrentTransformerType	Whether the current transformer at the metering installation is single phase or three phase. This value must correspond to a valid Current Transformer Type value in the Valid Transformer Fields values reference table listed in section 11.	REQUIRED NOT USED for NCONUML, BULK, XBOUNDRY and INTERCON	MPB
CurrentTransformerRatioAvailable	The available ratio of the current transformer at the metering installation. This value must correspond to a valid Current Transformer Ratio (Available) value in the Valid Transformer Fields values reference table listed in section 11.	REQUIRED NOT USED for NCONUML, BULK, XBOUNDRY and INTERCON	MPB
CurrentTransformerRatioConnected	The connected ratio of the current transformer at the metering installation. This value must correspond to a valid Current Transformer Ratio (Connected) value in the Valid Transformer Fields values reference table listed in section 11.	REQUIRED NOT USED for NCONUML, BULK, XBOUNDRY and INTERCON	MPB



Data Element Name	Description	Standing Data Required	Party to Provide
CurrentTransformerAccuracyClass	The accuracy class of the current transformer at the metering installation. This value must correspond to a valid Current Transformer Accuracy Class value in the Valid Transformer Fields values reference table listed in section 11.	REQUIRED NOT USED for BULK, XBOUNDRY and INTERCON	MPB
CurrentTransformerTest	Type of test performed on metering installation with Current Transformer which can be one of the following: <ul style="list-style-type: none"> TESTED (definition – part of 100% testing) SAMPLE TESTED (definition – tested as part of a sample plan) SAMPLE (definition – part of an approved sample plan) This value must correspond to a valid transformer test value in the Valid Transformer Test Values reference table listed in section 11.	REQUIRED NOT USED for BULK, XBOUNDRY and INTERCON	MPB
CurrentTransformerTestDate	A date that represents actual test date for metering installations with Current Transformer tested or date represents family expiry date for those included in an approved sample plan.	REQUIRED NOT USED for BULK, XBOUNDRY and INTERCON	MPB
GPSCoordinatesLat	GPS Coordinates Latitude is the angular measurement North or South of the equator in decimal degrees (5-7 decimal places). Angles South of the equator will be represented as negative values. E.g. -37.8886755. It is the latitude of the metering installation and not of the site.	For NMI's with manually read meters: REQUIRED for 36 months from effective date of these Procedures, MANDATORY thereafter. For NMI's with remotely read meters: MANDATORY for new NMI's established from the effective date of these Procedures and all NMI's when they have a physical field site visit, REQUIRED for all other NMI's. Where no GPS coverage is available, a value of	MPB

Data Element Name	Description	Standing Data Required	Party to Provide
		0.00000 (5-7 decimal places) is to used. Not Used for NMIS for Type 7 and NCONUML.	
GPSCoordinatesLong	GPS Coordinates Longitude is the angular measurement East or West of the prime meridian in decimal degrees (5-7 decimal places). Angles East of the Prime Meridian (e.g. Australia) will be represented as positive values. E.g. +145.1410361. It is the longitude of the metering installation and not of the site.	For NMIs with manually read meters: REQUIRED for 36 months from effective date of these Procedures, MANDATORY thereafter. For NMIs with remotely read meters: MANDATORY for new NMIs established from the effective date of these Procedures and all NMIs when they have a physical field site visit, REQUIRED for all other NMIs. Where no GPS coverage is available, a value of 0.00000 (5-7 decimal places) is to used. Not Used for NMIs for Type 7 and NCONUML.	MPB
LastTestDate	The date on which the <i>metering installation</i> was last tested or inspected by the Metering Provider “B”. This date will be used if clause 7.9.4(a) of the NER needs to be applied.	REQUIRED	MPB
Hazard	Free text or code identifying hazards associated with reading, maintaining or installing the <i>meter</i> . If the following are present at the <i>metering installation</i> , they should be listed in this field:	REQUIRED	MPB

Data Element Name	Description	Standing Data Required	Party to Provide
	Asbestos		
InstallationTypeCode	<p>The InstallationTypeCode may identify attributes of a physical <i>metering installation</i>, <i>metering data</i> collection methods or <i>metering data</i> calculation methods.</p> <p>This value must correspond to a valid Meter Installation Type Code as referenced in MSATS Procedures: GATS Procedures: Principles and Obligations for all Connection Points</p>	MANDATORY	MPB
Location	Free text descriptive material identifying the relationship between the location of the <i>metering point</i> and the <i>connection point</i> .	REQUIRED	MPB
Manufacturer	Free text field to identify the manufacturer of the installed <i>meter</i> . This field will be an enumerated list of values corresponding to current Meter Manufacturers in the industry with the options of UNMETERED and UNKNOWN.	MANDATORY	MPB
Model	Free text field to identify the <i>meter</i> manufacturer's designation for the <i>meter</i> model. This field will be an enumerated list of values corresponding to current Meter Models in the industry with the options of UNMETERED and UNKNOWN.	MANDATORY	MPB
ReadTypeCode	<p>Code to denote the method and frequency of Meter Reading.</p> <p>First Character = Remote (R) or Manual (M);</p> <p>Second Character = Mode</p> <p>T = telephone</p> <p>W = wireless</p> <p>P = powerline</p> <p>I = infra-red</p> <p>G = galvanic</p> <p>V = visual</p> <p>Third Character = Frequency of Scheduled Meter Readings</p> <p>1 = Twelve times per year</p> <p>2 = Six times per year</p> <p>3 = Four times per year</p> <p>D = Daily or weekly</p> <p>Fourth Character =</p> <ul style="list-style-type: none"> o A – 5 minute o B – 15 minute o C – 30 minute 	REQUIRED	MPB

Data Element Name	Description	Standing Data Required	Party to Provide
	<ul style="list-style-type: none"> o D – Cannot convert to 5-minute (i.e. due to metering installation de-energised) o M - Manually Read Accumulation Meter For example, MV3M = Manual, Visual, Quarterly, Manually Read Accumulation Meter; RWDC = Remote, Wireless, Daily, 30 minutes interval, RWD = Remote, Wireless, Daily (applicable for Vic AMI <i>metering installations</i> where InstallationTypeCode = 'MRIM' and JurisdictionCode = 'Victoria').		
SerialNumber	The Meter Serial ID uniquely identifies a <i>meter</i> for a given <i>NMI</i> . Maximum 12 Characters (alpha numeric). Unique for <i>NMI</i> . Use dummy for UMCP (Type 7), logical (meters) and <i>non-contestable unmetered loads</i> . Except for UMCP, logical, and <i>non-contestable unmetered loads</i> , SerialNumber should be as displayed on the physical device (also known as property number). SerialNumber to be property number if exists, otherwise the <i>meter</i> manufacturer's serial number, otherwise dummy number.	MANDATORY	MPB
Status	A code to denote the status of the <i>meter</i> . This value must correspond to a valid Meter Register Status as specified in the MSATS Procedures: GATS Procedures Principles and Obligations for all Connection Points .	MANDATORY	MPB
Use	A code identifying how the <i>meter</i> is used. This value must correspond to a valid Meter Use value in the Valid Meter Use Codes reference table listed in section 11.	MANDATORY	MPB
NextScheduledReadDate	Indicates the Scheduled Next Read Date for the <i>meter</i> if a manual Meter Reading is required.	MANDATORY for manually read meters, REQUIRED for Type 7 metering installations with calculated metering data where the forward estimate process is using a BLOCK methodology, and NOT USED for remotely read meters	MPB initially, then MDP for updates
NMI	<i>NMI</i> . This number is unique for each <i>connection point</i> within the <i>NEM</i> .	MANDATORY	LNSP

Data Element Name	Description	Standing Data Required	Party to Provide
TestResult	The result from the test performed on the date indicated in the LastTestDate field. This value must correspond to a valid Test Result value in the Valid Test Result Codes reference table listed in section 11.	REQUIRED	MPB
VoltageTransformerLocation	A free text field to indicate the location of the voltage transformer at the site.	REQUIRED NOT USED for NCONUML, BULK, XBOUNDRY and INTERCON	MPB
VoltageTransformerType	Whether the voltage transformer at the metering installation is single phase or three phase. This value must correspond to a valid Voltage Transformer Type value in the Valid Transformer Fields values reference table listed in section 11.	REQUIRED NOT USED for NCONUML, BULK, XBOUNDRY and INTERCON	MPB
VoltageTransformerRatio	The available or connected ratio of the voltage transformer at the metering installation. This value must correspond to a valid Voltage Transformer Ratio value in the Valid Transformer Fields values reference table listed in section 11.	REQUIRED NOT USED for NCONUML, BULK, XBOUNDRY and INTERCON	MPB
VoltageTransformerAccuracyClass	The accuracy class of the voltage transformer at the metering installation. This value must correspond to a valid Voltage Transformer Type value in the Valid Transformer Fields values reference table listed in section 11.	REQUIRED NOT USED for BULK, XBOUNDRY and INTERCON	MPB
VoltageTransformerTest	Type of test performed on metering installation with Voltage Transformer which can be one of the following: <ul style="list-style-type: none"> TESTED (definition – part of 100% testing) Sample SAMPLE TESTED (definition – tested as part of a sample plan) SAMPLE (definition – part of an approved sample plan) This value must correspond to a valid transformer test value in the Valid Transformer Test Values reference table listed in section 11.	REQUIRED NOT USED for BULK, XBOUNDRY and INTERCON	MPB
VoltageTransformerTestDate	A date that represents actual test date for metering installation with Voltage Transformer tested or date represents family expiry date for those included in an approved sample plan.	REQUIRED NOT USED for BULK, XBOUNDRY and INTERCON	MPB

Data Element Name	Description	Standing Data Required	Party to Provide
FromDate	Start date of the record. This indicates the date on which the parameters of this particular record apply from. The data applies from the beginning of this date (the start of the day, i.e. 00:00).	MANDATORY	Participant sending transaction
ToDate	End date of the record. This indicates the date on which the parameters of this particular record end. The data applies until the end of this date (the end of the day, i.e. 23:59). A default date of 9999-12-31 is recorded if EndDate is not provided.	MANDATORY (Defaults to high date unless supplied)	System generated unless supplied.
RowStatus	Indicates whether the record is active or inactive. Whenever a new record is created, it will be A (Active). A change to the data will make this record redundant and its MaintActFlg is changed to I (Inactive).	MANDATORY	System generated
MaintenanceDate	Date and time the record was updated. A default date of 9999-12-31 is used when the record is created initially. If the record is subsequently updated, its MaintUpdtDt is changed to the date and time the record was updated.	MANDATORY	System generated
CreationDate	Date and time the record was created.	MANDATORY	System generated

4.2. Cross Reference of Browser and aseXML Data Elements

The table below lists the names that are used in the MSATS browser. The table also provides the aseXML data element names and the respective formats used in each context.

In some cases, such as date fields, the format of the field is shown differently in the Browser to that used in the related aseXML transactions. Also, aseXML uses full words throughout, rather than the coded values used in the Browser.

Section 16 provides data type conventions of the Browser formats shown in this section.

Table 4 CATS_Meter_Register – Browser Cross Reference

Browser Field Name	aseXML Data Element Name	aseXML Path	Browser Format	aseXML Data Type
Current Transformer Location	CurrentTransformerLocation	ElectricityMeter/CurrentTransformerLocation	VARCHAR(50)	xsd:string maxLen = 50

Browser Field Name	aseXML Data Element Name	aseXML Path	Browser Format	aseXML Data Type
Current Transformer Type	CurrentTransformerType	ElectricityMeter/CurrentTransformerType	VARCHAR(20)	xsd:string maxLen = 20
Current Transformer RatioAvailable	CurrentTransformerRatioAvailable	ElectricityMeter/CurrentTransformerRatioAvailable	VARCHAR(50)	xsd:string maxLen = 50
Current Transformer RatioConnected	CurrentTransformerRatioConnected	ElectricityMeter/CurrentTransformerRatioConnected	VARCHAR(20)	xsd:string maxLen = 20
Current Transformer Accuracy Class	CurrentTransformerAccuracyClass	ElectricityMeter/CurrentTransformerAccuracyClass	VARCHAR(50)	xsd:string maxLen = 50
Current Transformer Test	CurrentTransformerTest	ElectricityMeter/CurrentTransformerTest	VARCHAR2(20)	xsd:string maxLen = 20
Current Transformer Test Date	CurrentTransformerTestDate	ElectricityMeter/LastTestDate	dd-mmm-yyyy	xsd:date
GPS Coordinates - Latitude	GPSCoordinates	ElectricityMeter/GPSCoordinates/Latitude	NUMERIC (s2.7)	xsd:decimal minIncl = -99.9999999 maxIncl = 99.9999999 totdig = 2 fracdig = 7
GPS Coordinates - Longitude	GPSCoordinates	ElectricityMeter/GPSCoordinates/Longitude	NUMERIC (s3.7)	xsd:decimal minIncl = 0 maxIncl = 999.9999999 totdig = 3 fracdig = 7
Last Test Date	LastTestDate	ElectricityMeter/LastTestDate	dd-mmm-yyyy	xsd:date
Meter Hazard	Hazard	ElectricityMeter/Hazard	VARCHAR2(100)	xsd:string maxLen = 100
Meter Installation Type Code	InstallationTypeCode	ElectricityMeter/InstallationTypeCode	VARCHAR2(8)	xsd:string maxLen = 8
Meter Location	Location	ElectricityMeter/Location	VARCHAR2(200) See AddlSiteInfo (above)	xsd:string maxLen = 200
Meter Manufacturer	Manufacturer	ElectricityMeter/Manufacturer	VARCHAR2(15)	xsd:string

Browser Field Name	aseXML Data Element Name	aseXML Path	Browser Format	aseXML Data Type
				maxLen = 15
Meter Model	Model	ElectricityMeter/Model	VARCHAR2(12)	xsd:string maxLen = 12
Meter Read Type	ReadTypeCode	ElectricityMeter/ReadTypeCode	VARCHAR(4)	xsd:string maxLen = 4
Meter Serial ID Meter ID (Different on two screens)	SerialNumber	ElectricityMeter/SerialNumber	VARCHAR2(12)	xsd:string maxLen = 12
Status Code	Status	ElectricityMeter/Status	CHAR(1)	xsd:string with enumeration
Meter Use	Use	ElectricityMeter/Use	VARCHAR2(10)	xsd:string maxLen = 10
Next Scheduled Read Date	NextScheduled ReadDate	ElectricityMeter/NextScheduled ReadDate	dd-mmm-yyyy	xsd:date
NMI	NMI	NMI	CHAR(10)	xsd:string maxLen = 10
Test Result	TestResult	ElectricityMeter/TestResult	VARCHAR2(4)	xsd:string maxLen = 4
Voltage Transformer Location	VoltageTransformerLocation	ElectricityMeter/VoltageTransformerLocation	VARCHAR(50)	xsd:string maxLen = 50
Voltage Transformer Type	VoltageTransformerType	ElectricityMeter/VoltageTransformerType	VARCHAR(50)	xsd:string maxLen = 50
Voltage Transformer Ratio	VoltageTransformerRatio	ElectricityMeter/VoltageTransformerRatio	VARCHAR(50)	xsd:string maxLen = 50
Voltage Transformer Accuracy Class	VoltageTransformerAccuracyClasses	ElectricityMeter/VoltageTransformerAccuracyClasses	VARCHAR(20)	xsd:string maxLen = 20
Voltage Transformer Test	VoltageTransformerTest	ElectricityMeter/VoltageTransformerTest	VARCHAR2(20)	xsd:string maxLen = 20



Browser Field Name	aseXML Data Element Name	aseXML Path	Browser Format	aseXML Data Type
Voltage Transformer Test Date	VoltageTransformerTestDate	ElectricityMeter/VoltageTransformerTestDate	dd-mmm-yyyy	xsd:date
Start Date	FromDate	FromDate	dd-mmm-yyyy	xsd:dateTime
End Date	ToDate	ToDate	dd-mmm-yyyy	xsd:dateTime
Updated On	MaintenanceDate	MaintenanceDate	dd-mmm-yyyy (summary screen) dd-mmm-yyyy hh:mm:ss (detail screen)	xsd:dateTime
Created On	CreationDate	CreationDate	dd-mmm-yyyy (summary screen) dd-mmm-yyyy hh:mm:ss (detail screen)	xsd:dateTime
Activity Status	RowStatus	RowStatus	CHAR(1)	xsd:string with enumeration

4.3. Field value examples

This section provides examples of typical sets of data element values associated with different types of *connection points*.

The data shown in each example is as shown in the Browser. This reverses the sequence of the day-month-year communicated via aseXML transactions.

Table 5 MSATS_Meter_Register - Example

Data Element Name (as it appears in XML documents)	Browser Field Name(as it appears in MSATS Browser)	Basic Example	Interval Example	Data Element Name
CurrentTransformerLocation	Current Transformer Location		BEHIND DOOR	CurrentTransformerLocation
CurrentTransformerType	Current Transformer Type		A	CurrentTransformerType
CurrentTransformerRatioAvailable	Current Transformer Ratio Available		20/50/100:5	CurrentTransformerRatio

Data Element Name (as it appears in XML documents)	Browser Field Name(as it appears in MSATS Browser)	Basic Example	Interval Example	Data Element Name
CurrentTransformerRatioConnected	Current Transformer Ratio Connected		400:5	CurrentTransformerRatio
CurrentTransformerAccuracyClass	Current Transformer Accuracy Class		0.2M	CurrentTransformerAccuracyClass
CurrentTransformerTest	Current Transformer Test		TESTED	CurrentTransformerTest
CurrentTransformerTestDate	Current Transformer Test Date		01-01-2020	CurrentTransformerTestDate
GPSCoordinates - Latitude	GPSCoordinatesLat	-37.8886755	-37.8886755	
GPSCoordinates - Longitude	GPSCoordinatesLong	+145.1410361	+145.1410361	
LastTestDate	Last Test Date	07-05-2004	07-03-2004	LastTestDate
Hazard	Meter Hazard		Asbestos	Hazard
InstallationTypeCode	Meter Installation Type Code	BASIC	COMMS4	InstallationTypeCode
Location	Meter Location	ON SUB POLE	BEHIND DOOR	Location
Manufacturer	Meter Manufacturer	EMAIL	EDMI	Manufacturer
Model	Meter Model	Q3	Q4	Model
ReadTypeCode	Meter Read Type	MV3M	RTDA	ReadTypeCode
SerialNumber	Meter Serial ID, Meter ID (Different on two screens)	525811	201000299	SerialNumber
Status	Status Code	C	C	Status
Use	Meter Use	REVENUE	REVENUE	Use
NextScheduledReadDate	Next Scheduled Read Date	04-10-2006		NextScheduledReadDate
NMI	NMI	1122334455	1122334455	NMI
TestResult	Test Result Accuracy	PASS	FAIL	TestResult
VoltageTransformerLocation	Voltage Transformer Location		BEHIND DOOR	VoltageTransformerLocation

Data Element Name (as it appears in XML documents)	Browser Field Name(as it appears in MSATS Browser)	Basic Example	Interval Example	Data Element Name
VoltageTransformerType	Voltage Transformer Type		IVT	VoltageTransformerType
VoltageTransformerRatio	Voltage Transformer Ratio		3300:110	VoltageTransformerRatio
VoltageTransformerAccuracyClass	Voltage Transformer Accuracy Class		0.01M	VoltageTransformerAccuracyClass
VoltageTransformerTest	Voltage Transformer Test		Tested	VoltageTransformerTest
VoltageTransformerTestDate	Voltage Transformer Test Date		01-01-2020	VoltageTransformerTestDate
FromDate	Start Date	14-03-1990	16-03-2002	FromDate
ToDate	End Date	31-12-9999	18-07-2006	ToDate
MaintenanceDate	Updated On	31-12-999 00:00:00	31-12-999 00:00:00	MaintenanceDate
CreationDate	Created On	19-03-1990 00:01:00	18-03-2002 00:01:00	CreationDate

5. CATS_DLF_CODES

5.1. Field Definitions

The CATS_DLF_Codes table contains a list of DLF Codes and their relevant values. The StartDate and DLFCode fields will need to be provided for *settlements* calculations.

Note: References to 'LNSP' include the ENM for child *connection points*.

Table 6 CATS_DLF_CODES – Field Definitions

Data Element Name	Description	Standing Data Required	Party to Provide
DistributionLossFactorCode	A four character alpha-numeric code used to identify DLF values. All <i>NM/s</i> must be assigned a DLF Code. Refer to AEMO Distribution Loss Factor documents for each financial year..	MANDATORY	AEMO

Data Element Name	Description	Standing Data Required	Party to Provide
DistributionLossFactorDescription	Description of the DLF Code and value.	MANDATORY	AEMO
DistributionLossFactor Value	Numeric value up to 5 decimal places, reflecting the value of the DLF Code.	MANDATORY	AEMO
JurisdictionCode	Jurisdiction code to which the <i>NMI</i> belongs. This value must correspond to Jurisdiction Code values as specified in the MSATS Procedures: Principles and Obligations for all Connection PointsGATS Procedures .	MANDATORY	AEMO
RowStatus	Indicates whether the DLF Code is active or inactive. Whenever a new record is created, it will be A (Active). A change to the data will make this record redundant and its MaintActFlg is changed to I (Inactive).	MANDATORY	System generated
FromDate	Start date of the record. This indicates the date on which the parameters of this particular record apply from. The data applies from the beginning of this date (the start of the day, i.e. 00:00).	MANDATORY	AEMO
ToDate	End date of the record. This indicates the date on which the parameters of this particular record end. The data applies until the end of this date (the end of the day, i.e. 23:59). A default date of 9999-12-31 is recorded if EndDate is not provided.	MANDATORY	System generated
MaintenanceDate	Date and time the record was updated. A default date of 9999-12-31 is used when the record is created initially. If the record is subsequently updated, its MaintUpdtDt is changed to the date and time the record was updated.	MANDATORY	System generated
CreationDate	Date and time the record was created.	MANDATORY	System generated

5.2. Cross Reference of Browser and aseXML Data Elements

The table below lists the names that are used in the MSATS browser. The table also provides the aseXML data element names and the respective formats used in each context.

In some cases, such as date fields, the format of the field is shown differently in the Browser to that used in the related aseXML transactions. Also, aseXML uses full words throughout, rather than the coded values used in the Browser.

Section 16 provides data type conventions of the Browser formats shown in this section.

Table 7 CATS_DLF_Codes - Browser Cross Reference

Browser Field Name	aseXML Data Element Name	aseXML Path	Browser Format	aseXML Data Type
DLF Code	DistributionLossFactorCode	DistributionLossFactorCode	VARCHAR2(4)	xsd:string maxLen = 4
Description	DistributionLossFactorDescription	DistributionLossFactorDescription	VARCHAR2(50)	xsd:string maxLen = 50
DLF Value	DistributionLossFactorValue	DistributionLossFactorValue	NUMBER(6,5)	xsd:decimal minIncl = 0 maxIncl = 6 totdig = 6 fracdig = 5
Jurisdiction	JurisdictionCode	ElectricityStandingData/MasterData/JurisdictionCode	VARCHAR2(3)	xsd:string maxLen = 3
Activity Status	RowStatus	RowStatus	CHAR(1)	xsd:string with enumeration
Start Date	FromDate	FromDate	dd-mmm-yyyy	xsd:dateTime
End Date	ToDate	ToDate	dd-mmm-yyyy	xsd:dateTime
Updated On	MaintenanceDate	MaintenanceDate	dd-mmm-yyyy (summary screen) dd-mmm-yyyy hh:mm:ss (detail screen)	xsd:dateTime
	CreationDate	CreationDate	dd-mmm-yyyy (summary screen) dd-mmm-yyyy hh:mm:ss (detail screen)	xsd:dateTime

5.3 Field value examples

This section provides examples of typical sets of data element values associated with different types of *connection points*.

The data shown in each example is as shown in the Browser. This reverses the sequence of the day-month-year communicated via aseXML transactions.

Table 8 CATS_DLF_Codes - Example

Data Element Name	Browser Field Name	Basic & Interval Example
DistributionLossFactorCode	DLF Code	NHV1
DistributionLossFactorDescription	Description	UMPLP - High Voltage
DistributionLossFactorValue	[The actual DLF value]	1.11111
JurisdictionCode	Jurisdiction Code	SA
RowStatus	Activity Status	A
FromDate	Start Date	01-07-1999
ToDate	End Date	30-06-2000
MaintenanceDate	Updated On	31-05-2000 00:30:27
CreationDate		01-06-1999 00:23:32

6. CATS_EMB_NET_ID_CODES

6.1. Field Definitions

The CATS_EMB_NET_ID_CODES table contains embedded network identifier codes, which are used to identify which *embedded network* a *NMI* belongs to, either as a Parent NMI or a Child NMI.

Note: References to 'LNSP' include the ENM for *child connection points*.

Table 9 CATS_EMB_NET_ID_CODES – Field Definitions

Data Element Name	Description	Standing Data Required	Party to Provide
EmbeddedNetworkIdentifier	Embedded Network Code. Refer to Allocation of Embedded Network Codes for further details.	MANDATORY	AEMO
EmbeddedNetworkDescription	Description of embedded network identifier.	MANDATORY	AEMO
SuburbOrPlaceOrLocality	Locality to which the embedded network identifier belongs.	MANDATORY	AEMO
PostCode	Postcode for the locality to which the embedded network identifier belongs.	MANDATORY	AEMO
StateOrTerritory	State or Territory abbreviation in accordance with AS 4590.	MANDATORY	AEMO
RowStatus	Indicates whether the code is active or inactive. Whenever a new record is created, it will be A (Active). A change to the data will make this record redundant and its MaintActFlg is changed to I (Inactive).	MANDATORY	System generated
FromDate	Start date of the record. This indicates the date on which the parameters of this particular record apply from. The data applies from the beginning of this date (the start of the day, i.e. 00:00).	MANDATORY	AEMO
ToDate	End date of the record. This indicates the date on which the parameters of this particular record end. The data applies until the end of this date (the end of the day, i.e. 23:59). A default date of 9999-12-31 is recorded if EndDate is not provided.	MANDATORY	System generated
MaintenanceDate	Date and time the record was updated. A default date of 9999-12-31 is used when the record is created initially. If the record is subsequently updated, its MaintUpdtDt is changed to the date and time the record was updated.	MANDATORY	System generated
CreationDate	Date and time the record was created.	MANDATORY	System generated

6.2. Cross Reference of Browser and aseXML Data Elements

The table below lists the names that are used in the MSATS browser. The table also provides the aseXML data element names and the respective formats used in each context.

In some cases, such as date fields, the format of the field is shown differently in the Browser to that used in the related aseXML transactions. Also, aseXML uses full words throughout, rather than the coded values used in the Browser.

Section 16 provides data type conventions of the Browser formats shown in this section.

Table 10 CATS_Emb_Net_ID_Codes - Browser Cross Reference

Browser Field Name	aseXML Data Element Name	aseXML Path	Browser Format	aseXML Data Type
Code	EmbeddedNetworkIdentifier	EmbeddedNetworkIdentifier	VARCHAR2(10)	xsd:string maxLen = 10
Description	EmbeddedNetworkDescription	EmbeddedNetworkDescription	VARCHAR2(50)	xsd:string maxLen = 50
Locality/Suburb	SuburbOrPlaceOrLocality	ElectricityStandingData/MasterData/Address/AustralianAddresses/SuburbOrPlaceOrLocality	VARCHAR2(46)	xsd:string maxLen = 46
Postcode	PostCode	ElectricityStandingData/MasterData/Address/AustralianAddresses/PostCode	VARCHAR2(4)	xsd:string pattern: [\p{N}]{4}
State	StateOrTerritory	ElectricityStandingData/MasterData/Address/AustralianAddresses/StateOrTerritory	VARCHAR2(3)	xsd:string with enumerations
Activity Status	RowStatus	RowStatus	CHAR(1)	xsd:string with enumeration
Start Date	FromDate	FromDate	dd-mmm-yyyy	xsd:dateTime
End Date	ToDate	ToDate	dd-mmm-yyyy	xsd:dateTime

Browser Field Name	aseXML Data Element Name	aseXML Path	Browser Format	aseXML Data Type
Updated On	MaintenanceDate	MaintenanceDate	dd-mmm-yyyy (summary screen) dd-mmm-yyyy hh:mm:ss (detail screen)	xsd:dateTime
Created On	CreationDate	CreationDate	dd-mmm-yyyy (summary screen) dd-mmm-yyyy hh:mm:ss (detail screen)	xsd:dateTime

6.3. Field value examples

This section provides examples of typical sets of data element values associated with different types of *connection points*.

The data shown in each example is as shown in the Browser. This reverses the sequence of the day-month-year communicated via aseXML transactions.

Table 11 CATS_Emb_Net_ID_Codes - Example

Data Element Name	Browser Field Name	Basic & Basic Example
EmbeddedNetworkIdentifier	Code	SE01008111
EmbeddedNetworkDescription	Description	Kingston-On-Murray Caravan Park
SuburbOrPlaceOrLocality	Suburb / Locality	Kingston-On-Murray
PostCode	Postcode	5331
StateOrTerritory	State	SA
RowStatus	Activity Status	A
FromDate	Start Date	5/04/2003
ToDate	End Date	31/12/9999

Data Element Name	Browser Field Name	Basic & Basic Example
MaintenanceDate	Updated On	31/12/9999
CreationDate	Creation On	1/04/2003 13:23

7. CATS_NMI_DATA

7.1. Field Definitions

The CATS_NMI_DATA table records Master NMI Record data information. It is updated whenever a Change Request containing data in the CATS_INBOUND_NMI_DATA table is completed.

Note: References to 'LNSP' include the ENM for *child connection points*.

Table 12 CATS_NMI_DATA – Field Definitions

Data Element Name	Description	Standing Data Required	Party to Provide
NMI	<i>NMI</i> . All alpha characters are Upper Case	MANDATORY	LNSP
NMI ClassificationCode	Code used to indicate the NMI Classification Code of this <i>NMI</i> . This value must correspond to NMI Classification Code values as specified in the MSATS Procedures: Principles and Obligations for all Connection PointsCATS Procedures .	MANDATORY	LNSP
MasterData/ StatusCode	Code used to indicate the status of the <i>NMI</i> . This value must correspond to NMI Status Code values as specified in the MSATS Procedures: Principles and Obligations for all Connection PointsCATS Procedures .	MANDATORY	LNSP
TransmissionNode Identifier	This value must correspond to a valid code in the CATS_TNI_Codes table.	MANDATORY	LNSP
TransmissionNode Identifier2	TNI Code assigned, by AEMO, to a distribution network into which energy normally flows through a connection point between adjacent distribution networks that has a single NMI. This value must correspond to a valid code in the CATS_TNI_Codes table.	REQUIRED	AEMO
SharedIsolationPoin	A flag (Yes, No, Isolated or Unknown) to indicate the Shared Fuse Arrangement for the <i>metering</i>	MANDATORY	LNSP

Data Element Name	Description	Standing Data Required	Party to Provide
tFlag	<i>installation</i> . Valid values are Y, N, I or U. This value must correspond to a valid shared isolation point flag value in the Valid Shared Isolation Point Flag Values reference table listed in section 11.		
MeterMalfunctionExemptionNumber	The exemption number granted by AEMO when a meter malfunction exemption is granted .	REQUIRED	AEMO
MeterMalfunctionExemptionExpiryDate	The end date of the malfunction exemption.	REQUIRED	AEMO
JurisdictionCode	Jurisdiction code to which the <i>NMI</i> belongs. This code defines the jurisdictional rules which apply to the transfer of this <i>NMI</i> . This value must correspond to Jurisdiction Code values as specified in the MSATS Procedures: Principles and Obligations for all Connection Points CATS Procedures .	MANDATORY	LNSP
DistributionLossFactorCode	Distribution Loss Factor Code. Must be a valid code in the CATS_DLF_Codes table.	MANDATORY	LNSP
ConnectionConfiguration	Two-character code to denote information about the configuration of the connection point. First Character = Connection Type. H = <i>High voltage</i> (as defined in the NER) L = Low voltage (lower than the threshold defined for <i>high voltage</i> in the NER) Second Character = Phases In Use. This refers to phases to the NMI. 1 = Single Phase 2 = Two-Phase 3 = Three-Phase Information registered with a Greenfield NMI may be subject to change during the connection process. Information may be subject to change during the NMI lifecycle.	MANDATORY	LNSP
ChildEmbeddedNetworkIdentifier	The embedded network identifier code is used to identify which embedded network this given <i>NMI</i> is the 'child of'. (If on a NMI record this field is not populated, it is assumed the <i>NMI</i> is not the child of any other <i>NMI</i> .) Must be a valid code within the CATS_Emb_Net_ID_Codes table. This field cannot be used unless the Parent NMI has been created and assigned an embedded network identifier code. Refer section 2.11 (f) of the MSATS Procedure: Principles and Obligations for all Connection Points CATS Procedure .	REQUIRED	LNSP
ParentEmbedded	The embedded network identifier code is used to identify which <i>embedded network</i> this given <i>NMI</i> is the	REQUIRED	LNSP

Data Element Name	Description	Standing Data Required	Party to Provide
NetworkIdentifier	'parent of'. (If on a NMI record this field is not populated, it is assumed the <i>NMI</i> is not the parent of any other <i>NMI</i> .) Must be a valid code within the CATS_Emb_Net_ID_Codes table.		
BuildingOrPropertyName	A free text description of the full name used to identify the physical building or property as part of its location. Defines the building or property name, reference AS4590.	REQUIRED	LNSP
LotNumber	The lot reference number allocated to an address prior to street numbering. The word 'LOT' is not required.	REQUIRED	LNSP
FlatOrUnitNumber	Specification of the number of the flat or unit which is a separately identifiable portion within a building/complex.	REQUIRED	LNSP
FlatOrUnitType	Specification of the type of flat or unit which is a separately identifiable portion within a building/complex. This value must correspond to a valid Flat Type Code, reference AS4590.	REQUIRED	LNSP
FloorOrLevelNumber	Floor Number is used to identify the floor or level of a multi-storey building/complex.	REQUIRED	LNSP
FloorOrLevelType	Floor Type is used to identify the floor or level of a multi-storey building/complex. This value must correspond to a valid Floor Type Code in the Floor Type Codes, reference AS4590.	REQUIRED	LNSP
HouseNumber	The numeric reference of a house or property. Specifically the house number.	REQUIRED	LNSP
HouseNumberSuffix	The numeric reference of a house or property. Specifically the single character identifying the house number suffix.	REQUIRED	LNSP
HouseNumberTo	The numeric reference of a house or property for scenarios where the address is similar to 4-10 Smith St. For example, HouseNumber = 4 and HouseNumberTo = 10 where the address is 4-10 Smith St.	REQUIRED	LNSP
HouseNumberToSuffix	The numeric reference of a house or property. Specifically the single character identifying the house number suffix to for scenarios where the address is similar to 4A-4B Smith St. For examples, HouseNumber = 4, HouseNumberSuffix = A, HouseNumberTo = 4 and HouseNumberToSuffix = B where the address is 4A-4B Smith St.	REQUIRED	LNSP
StreetName	Records the thoroughfare name. See notes at end of table for more information on Structured Addresses	REQUIRED	LNSP
StreetSuffix	Records street suffixes. This value must correspond to a valid Street Suffix Code, reference AS4590.	REQUIRED	LNSP

Data Element Name	Description	Standing Data Required	Party to Provide
StreetType	Records the street type abbreviation. This value must correspond to a valid Street Type Code, reference AS4590.	REQUIRED	LNSP
SuburbOrPlaceOrLocality	The full name of the general locality containing the specific address.	MANDATORY	LNSP
LocationDescriptor	A general field to capture various references to address locations alongside another physical location.	REQUIRED	LNSP
PostCode	The descriptor for a postal delivery area, aligned with locality, suburb or place.	MANDATORY	LNSP
StateOrTerritory	Defined State or Territory abbreviation.	MANDATORY	LNSP
GNAFPID	The Geocoded National Address File (G-NAF) Persistent Identifier (PID) for a given address.	REQUIRED	LNSP/ AEMO
SectionNumber	A section number corresponds to a reference that contributes to defining the legal boundaries of a plot of land in NSW and ACT	REQUIRED for NSW and ACT OPTIONAL in all other jurisdictions	LNSP
DPNumber	A deposited plan (DP) number corresponds to an image that defines the legal boundaries of a plot of land in NSW and ACT	REQUIRED for NSW and ACT OPTIONAL in all other jurisdictions	LNSP
DeliveryPointIdentifier	Delivery point identifier - the numeric descriptor for a postal delivery point which is equal to a physical address. The values are in the range 10000000 – 99999999.	REQUIRED	LNSP/ AEMO
Aggregate	This flag determines whether the energy at this <i>connection point</i> is to be treated as consumer <i>load</i> or as a <i>generating unit</i> (this may include <i>generator</i> auxiliary loads). MSATS will initially set this field to “Y” This value must correspond to a valid Aggregate value in the Aggregate Codes reference table listed in section 11.	OPTIONAL	(Defaults to ‘Y’, AEMO updates to ‘N’ as required)

Data Element Name	Description	Standing Data Required	Party to Provide
Feeder Class	A code to provide Participants with information to indicate the appropriate service level timeframes for performing work in relation to Service Order Requests.	Required in QLD where relevant OPTIONAL in all other jurisdictions	LNSP
Customer Classification Code	A code that defines the consumer class as defined in the National Energy Retail Regulations, or in overriding Jurisdictional instruments.	MANDATORY	Current FRMP
Customer Classification Threshold Code	A code that defines the consumption threshold as defined in the National Energy Retail Regulations, or in overriding Jurisdictional instruments.	MANDATORY	LNSP
Last Consumer Change Date	The date a consumer starts or ends as the account holder for a premises.	MANDATORY	Current FRMP
FromDate	Start date of the NMI Data record. This indicates the date on which the parameters of this particular NMI data record apply from. The data applies from the beginning of this date (the start of the day, i.e. 00:00).	MANDATORY	LNSP
ToDate	End date of the record. This indicates the date on which the parameters of this particular record end. The data applies until the end of this date (the end of the day, i.e. 23:59). A default date of 9999-12-31 is recorded if EndDate is not provided.	MANDATORY (Defaults to high date unless supplied)	System generated unless supplied.
RowStatus	Indicates whether the record is active or inactive. Whenever a new record is created, it will be A (Active). A change to the data will make this record redundant and its MaintActFlg is changed to I (Inactive).	MANDATORY	System generated
MaintenanceDate	Date and time the record was updated. A default date of 9999-12-31 is used when the record is created initially. If the record is subsequently updated, its MaintUpdtDt is changed to the date and time the record was updated.	MANDATORY	System generated
CreationDate	Date and time the record was created.	MANDATORY	System generated

7.2. Cross Reference of Browser and aseXML Data Elements

The table below lists the names that are used in the MSATS browser. The table also provides the aseXML data element names and the respective formats used in each context.

In some cases, such as date fields, the format of the field is shown differently in the Browser to that used in the related aseXML transactions. Also, aseXML uses full words throughout, rather than the coded values used in the Browser.

Section 16 provides data type conventions of the Browser formats shown in this section.

Table 13 CATS_NMI_Data

Browser Field Name	aseXML Data Element Name	aseXML Path	Browser Format	aseXML Data Type
NMI	NMI	NMI	CHAR(10)	xsd:string maxLen = 10
NMI Classification Code	NMClassificationCode	ElectricityStandingData/MasterData/ NMClassificationCode	VARCHAR2(8)	xsd:string maxLen = 8
Status Code	Status	ElectricityStandingData/MasterData/Status	CHAR(1)	xsd:string maxLen = 1
TNI Code	TransmissionNodeIdentifier	ElectricityStandingData/MasterData/TransmissionNodeIdentifier	VARCHAR2(4)	xsd:string maxLen = 4
TNI Code 2	TransmissionNodeIdentifier2	ElectricityStandingData/MasterData/TransmissionNodeIdentifier2	VARCHAR2(4)	xsd:string maxLen = 4
Shared Isolation Point Flag	SharedIsolationPointFlag	ElectricityMeter/ SharedIsolationPointFlag	CHAR(1)	xsd:string maxLen = 1
Meter Malfunction Exemption Number	MeterMalfunctionExemptionNumber	ElectricityMeter/MeterMalfunctionExemptionNumber	VARCHAR2(15)	xsd:string maxLen = 15
Meter Malfunction Exemption Expiry Date	MeterMalfunctionExemptionExpiryDate	ElectricityMeter/MeterMalfunctionExemptionExpiryDate	dd-mmm-yyyy	xsd:date
Jurisdiction Code	JurisdictionCode	JurisdictionCode	VARCHAR2(3)	xsd:string maxLen = 3

Browser Field Name	aseXML Data Element Name	aseXML Path	Browser Format	aseXML Data Type
Connection Configuration	ConnectionConfiguration	ElectricityMeter/ConnectionConfiguration	VARCHAR2(2)	xsd:string maxLen = 2
DLF Code	DistributionLossFactorCode	ElectricityStandingData/MasterData/DistributionLossFactorCode	VARCHAR2(4)	xsd:string maxLen = 4
Embedded Network ID (Child)	ChildEmbeddedNetworkIdentifier	ElectricityStandingData/MasterData/ChildEmbeddedNetworkIdentifier	VARCHAR2(10)	xsd:string maxLen = 10
Embedded Network (Parent)	ParentEmbeddedNetworkIdentifier	ElectricityStandingData/MasterData/ParentEmbeddedNetworkIdentifier	VARCHAR2(10)	xsd:string maxLen = 10
Building / Property Name	BuildingOrPropertyName	ElectricityStandingData/MasterData/Address/AustralianAddress/StructuredAddress/BuildingOrPropertyName	VARCHAR2(30)	xsd:string maxLen = 30 x 2
Lot Number	LotNumber	ElectricityStandingData/MasterData/Address/AustralianAddress/StructuredAddress/Lot/LotNumber	VARCHAR2(6)	xsd:string pattern: [\p{L}\p{N}\p{P}]{1,6}
Flat/Unit Number	FlatOrUnitNumber	ElectricityStandingData/MasterData/Address/AustralianAddress/StructuredAddress/FlatOrUnit/FlatOrUnitNumber	VARCHAR2(7)	xsd:string pattern: [\p{L}\p{N}\p{P}]{1,7}
Flat/Unit Type	FlatOrUnitType	ElectricityStandingData/MasterData/Address/AustralianAddress/StructuredAddress/FlatOrUnit/FlatOrUnitType	VARCHAR2(4)	xsd:string with enumerations
Floor/Level Number	FloorOrLevelNumber	ElectricityStandingData/MasterData/Address/AustralianAddress/StructuredAddress/FloorOrLevel/FloorOrLevelNumber	VARCHAR2(5)	xsd:string [\p{L}\p{N}\p{P}]{1,5}
Floor/Level Type	FloorOrLevelType	ElectricityStandingData/MasterData/Address/AustralianAddress/StructuredAddress/FloorOrLevel/FloorOrLevelType	VARCHAR2(2)	xsd:string with enumerations
House Number	HouseNumber	ElectricityStandingData/MasterData/Address/AustralianAddress/StructuredAddress/House/HouseNumber	NUMBER(5)	xsd:nonNegativeInteger maxIncl = 99999
House Number Suffix	HouseNumberSuffix	ElectricityStandingData/MasterData/Address/AustralianAddress/StructuredAddress/House/HouseNumberSuffix	VARCHAR2(1)	xsd:string pattern: [\p{L}\p{N}]{1}

Browser Field Name	aseXML Data Element Name	aseXML Path	Browser Format	aseXML Data Type
House Number To	HouseNumberTo	ElectricityStandingData/MasterData/Address/AustralianAddress/StructuredAddress/House/HouseNumberTo	NUMBER(5)	xsd:nonNegativeInteger maxIncl = 99999
House Number To Suffix	HouseNumberToSuffix	ElectricityStandingData/MasterData/Address/AustralianAddress/StructuredAddress/House/HouseNumberSuffixTo	VARCHAR2(1)	xsd:string pattern: [\p{L}\p{N}]{1}
Street Name	StreetName	ElectricityStandingData/MasterData/Address/AustralianAddress/StructuredAddress/Street/StreetName	VARCHAR2(30)	xsd:string pattern: [\p{L}\p{N}\s\-\-]{1,30}
Street Name Suffix	StreetSuffix	ElectricityStandingData/MasterData/Address/AustralianAddress/StructuredAddress/Street/StreetSuffix	VARCHAR2(2)	xsd:string with enumerations
Street Type	StreetType	ElectricityStandingData/MasterData/Address/AustralianAddress/StructuredAddress/Street/StreetType	VARCHAR2(4)	xsd:string with enumerations
Suburb/Locality	SuburbOrPlaceOrLocality	ElectricityStandingData/MasterData/Address/AustralianAddress/SuburbOrPlaceOrLocality	VARCHAR2(46)	xsd:string maxLen = 46
Location Descriptor	LocationDescriptor	ElectricityStandingData/MasterData/Address/AustralianAddress/StructuredAddress/LocationDescriptor	VARCHAR2(200)	xsd:string pattern: [\p{L}\p{N}\p{P}\s]{1,30}
Postcode	PostCode	ElectricityStandingData/MasterData/Address/AustralianAddress/PostCode	VARCHAR2(4)	xsd:string pattern: [\p{N}]{4}
State	StateOrTerritory	ElectricityStandingData/MasterData/Address/AustralianAddress/StateOrTerritory	VARCHAR2(3)	xsd:string with enumerations
DPID	DeliveryPointIdentifier	ElectricityStandingData/MasterData/Address/AustralianAddress/StructuredAddress/DeliveryPointIdentifier	NUMBER(8)	xsd:nonNegativeInteger minIncl = 10000000 maxIncl = 99999999

Browser Field Name	aseXML Data Element Name	aseXML Path	Browser Format	aseXML Data Type
GNAF PID	GNAFPID	ElectricityStandingData/MasterData/Address/AustralianAddress/StructuredAddress/GNAFPID	VARCHAR2(20)	xsd:string maxLen = 20
Section Number	SectionNumber	ElectricityStandingData/MasterData/Address/AustralianAddress/StructuredAddress/SectionNumber	VARCHAR2(20)	xsd:string maxLen = 20
DP Number	DPNumber	ElectricityStandingData/MasterData/Address/AustralianAddress/StructuredAddress/DPNumber	VARCHAR2(20)	xsd:string maxLen = 20
Aggregate Flag	Aggregate	ElectricityStandingData/MasterData/Aggregate	CHAR(1)	xsd:string with enumeration
Start Date	FromDate	FromDate	dd-mmm-yyyy	xsd:dateTime
End Date	ToDate	ToDate	dd-mmm-yyyy	xsd:dateTime
Updated On	MaintenanceDate	MaintenanceDate	dd-mmm-yyyy (summary screen) dd-mmm-yyyy hh:mm:ss (detail screen)	xsd:dateTime
Created On	CreationDate	CreationDate	dd-mmm-yyyy (summary screen) dd-mmm-yyyy hh:mm:ss (detail screen)	xsd:dateTime
Activity Status	RowStatus	RowStatus	CHAR(1)	xsd:string with enumeration
Feeder Class	Feeder Class	ElectricityStandingData/MasterData/FeederClass	VARCHAR2(15)	xsd:string maxLen = 15

Browser Field Name	aseXML Data Element Name	aseXML Path	Browser Format	aseXML Data Type
Customer Classification Code	CustomerClassificationCode	ElectricityStandingData/MasterData/CustomerClassificationCode	VARCHAR2(20)	xsd:string maxLen = 20
Last Consumer Change Date	LastConsumerChangeDate	ElectricityStandingData/MasterData/LastConsumerChangeDate	dd-mmm-yyyy	xsd:date
Customer Classification Threshold Code	CustomerThresholdCode	ElectricityStandingData/MasterData/CustomerThresholdCode	VARCHAR2(20)	xsd:string maxLen = 20

7.3. Field value examples

This section provides examples of typical sets of data element values associated with different types of *connection points*.

The data shown in each example is as shown in the Browser. This reverses the sequence of the day-month-year communicated via aseXML transactions.

Table 14 CATS_NMI_Data Field value examples

Data Element Name	Browser Field Name	Basic Example	Interval Example
NMI	NMI	122334451	1122334455
NMClassificationCode	NMI Classification Code	SMALL	LARGE
MasterData/Status	Status Code	A	G
TransmissionNodeIdentifier	TNI Code	NRGE	SBER
TransmissionNodeIdentifier2	TNI Code 2		SORA
SharedIsolationPointFlag	Shared Isolation Point Flag	N	Y
MeterMalfunctionExemption Number	Meter Malfunction Exemption Number	100000000001234	100000000001234
MeterMalfunctionExemptionExpiry Date	Meter Malfunction Exemption Expiry Date	07-05-2020	07-05-2020
JurisdictionCode	Jurisdiction Code	NSW	SA

Data Element Name	Browser Field Name	Basic Example	Interval Example
ConnectionConfiguration	Connection Configuration	L1	H3
DistributionLossFactorCode	DLF Code	NRGE	NLV2
ChildEmbeddedNetworkIdentifier	Embedded Network ID (Child)	NS01008111	SE01008111
ParentEmbeddedNetworkIdentifier	Embedded Network (Parent)	NS01008111	SE01008111
BuildingOrPropertyName	Building / Property Name	BP	SHELL
LotNumber	Lot Number	22	23
FlatOrUnitNumber	Flat/Unit Number	1	2
FlatOrUnitType	Flat/Unit Type	U	U
FloorOrLevelNumber	Flat/Unit Number	1	1
FloorOrLevelType	Floor/Level Type	FL	FL
HouseNumber	House Number	6	10
HouseNumberSuffix	House Number Suffix	A	B
HouseNumberTo	House Number To	10	17
HouseNumberToSuffix	House Number To Suffix	B	C
StreetName	Street Name	BORIS	DORIS
StreetSuffix	Street Name Suffix	N	W
StreetType	Street Type	DR	ST
SuburbOrPlaceOrLocality	Suburb/Locality	ORANGE	LOXTON
LocationDescriptor	Location Descriptor	CNR FRED ST	SHELL SERVICE STATION
PostCode	Postcode	2211	5333
StateOrTerritory	State	NSW	SA
DeliveryPointIdentifier	DPID	01234567	12345678

Data Element Name	Browser Field Name	Basic Example	Interval Example
GNAFPID	GNAF PID	GDA2020	GDA2020
SectionNumber	Section Number	Section 23K	Section 23K
DPNumber	DP Number	DP 825310	DP 825310
Aggregate	Aggregate Flag	Y	Y
FromDate	Start Date	01-06-2004	01-06-2001
ToDate	End Date	31-12-9999	01-01-2003
MaintenanceDate	Updated On	31-12-9999 00:00:00	05-01-2003 00:01:00
CreationDate	Created On	04-01-2004 09:31:00	01-06-2001 00:01:00
RowStatus	Activity Status	A	A
FeederClass	Feeder Class	ERGUD	ERGUD
Customer ClassificationCode	Customer Classification	RESIDENTIAL	BUSINESS
Last Consumer Change Date	LastConsumerChangeDate	01-05-2023	01-05-2023
CustomerThresholdCode	Customer Threshold	LOW	HIGH

8. CATS_NMI_DATA_STREAM

8.1. Field Definitions

The CATS_NMI_Data_Stream table is a NMI master table containing data that is stored at the *NMI* Datastream level. Information stored at this level includes suffixes, profile name, average daily load etc. It is updated whenever a Change Request containing inbound Datastream data is completed.

Note: Data is only required for this table if the *NMI* is active in the NEM or is used for profile peel-off in accordance with the Metrology Procedure.

Note: References to 'LNSP' include the ENM for *child connection points*.

Table 15 CATS_NMI_DATA_STREAM – Field Definitions

Data Element Name	Description	Standing Data Required	Party to Provide
NMI	<i>NMI</i>	MANDATORY	MDP LNSP
ElectricityDataStream/Suffix	The Metering Datastream identifier (for MDM). Identifies the ElectricityDataStream Suffix as delivered to AEMO for NEM Settlement calculations, profile peeloff, UFE analysis and Vic TUOS sites. The value must be a valid as per Datastream suffix details specified in the MSATS Procedures: National Metering Identifier procedure. The value must match the MDMContributorySuffix value provided in an MDFF File.	MANDATORY	MDP
ElectricityDataStream/Status	Code used to indicate the status of the suffix. This value must correspond to a valid Datastream Status Code as specified in the MSATS Procedures: Principles and Obligations for all Connection PointsGATS procedures .	MANDATORY	MDP
AveragedDailyLoad	The <i>energy</i> delivered or generation delivered via a datastream over an extended period normalised to a "per day" basis (kWh).	MANDATORY	MDP
DataStreamType	Indicates the primary function of the ElectricityDatastream Suffix. i.e. inclusion within NEM Settlement calculations, UFE analysis, profile peeloff or Vic TUOS. This value must correspond to a valid DataStreamType in the Data Stream Type Codes reference table listed in section 11.	MANDATORY	MDP
ProfileName	The Profile Name is a code that identifies the name of the algorithmically derived shape that is used to allocate a Datastream's consumption to TIs. This value must correspond to a valid code in the PROFILE table. For all Interval Meters and sample <i>meters</i> , this must be set to 'NOPROF'. For Accumulation Meters, refer to the MDM Profile for valid profile names. <ul style="list-style-type: none"> In Victoria and the ACT, ProfileName must be NSLP. InQLD and SA, ProfileName must be NSLP or the relevant controlled load profile. This value must correspond to a valid ProfileName value in the Profile Codes reference table listed in section 11.	MANDATORY	MDP
FromDate	Start date of the <i>NMI</i> data record. This indicates the date on which the parameters of this particular <i>NMI</i> data record apply from. The data applies from the beginning of this date (the start of the day, i.e. 00:00).	MANDATORY	Party sending transaction

Data Element Name	Description	Standing Data Required	Party to Provide
ToDate	End date of the record. This indicates the date on which the parameters of this particular record end. The data applies until the end of this date (the end of the day, i.e. 23:59). A default date of 9999-12-31 is recorded if EndDate is not provided.	MANDATORY (Defaults to high date unless supplied)	System generated unless supplied.
RowStatus	Indicates whether the record is active or inactive. Whenever a new record is created, it will be A (Active). A change to the data will make this record redundant and its MaintActFlg is changed to I (Inactive).	MANDATORY	System generated
MaintenanceDate	Date and time the record was updated. A default date of 9999-12-31 is used when the record is created initially. If the record is subsequently updated, its MaintUpdtDt is changed to the date and time the record was updated.	MANDATORY	System generated
CreationDate	Date and time the record was created.	MANDATORY	System generated

8.2. Cross Reference of Browser and aseXML Data Elements

The table below lists the names that are used in the MSATS browser. The table also provides the aseXML data element names and the respective formats used in each context.

In some cases, such as date fields, the format of the field is shown differently in the Browser to that used in the related aseXML transactions. Also, aseXML uses full words throughout, rather than the coded values used in the Browser.

Section 16 provides data type conventions of the Browser formats shown in this section.

Table 16 CATS_NMI_DATA_STREAM- Browser cross reference

Browser Field name	aseXML Data Element Name	aseXML Path	BrowserFormat	aseXMLData Type
NMI	NMI	NMI	CHAR(10)	xsd:string maxLen=10
Suffix	Suffix	ElectricityDatastream/Suffix	VARCHAR2(2)	xsd:string maxLen=2
Status Code	Status	ElectricityDatastream/Status	CHAR(1)	xsd:string maxLen=10
Average Daily Load	AverageDailyLoad	ElectricityDatastream/AverageDailyLoad	NUMBER(10)	xsd:integer
Type	DataStreamType	ElectricityDatastream/DatastreamType	CHAR(1)	xsd:string with enumeration
Profile Name	ProfileName	ElectricityDatastream/ProfileName	VARCHAR2(10)	xsd:string maxLen=10
Start Date	FromDate	FromDate	dd-mmm-yyyy	xsd:dateTime
End Date	ToDate	ToDate	dd-mmm-yyyy	xsd:dateTime
Updated On	MaintenanceDate	MaintenanceDate	dd-mmm-yyyy (Summary Screen) dd-mmm-yyyy hh:mm:ss (Detail Screen)	xsd:dateTime
Created On	CreationDate	CreationDate	dd-mmm-yyyy (Summary Screen) dd-mmm-yyyy hh:mm:ss (Detail Screen)	xsd:dateTime
Activity Status	RowStatus	RowStatus	CHAR(1)	xsd:string with enumeration

8.3. Field value examples

This section provides examples of typical sets of data element values associated with different types of *connection points*.

The data shown in each example is as shown in the Browser. This reverses the sequence of the day-month-year communicated via aseXML transactions.

Table 17 CATS_NMI_Data_Stream – Examples

Data Element Name	Browser Field Name	Basic Example	Interval Example
NMI	NMI	1100445566	2211335544
ElectricityDataStream/Suffix	Suffix	31	N1
ElectricityDataStream/Status	Status Code	A	A
ElectricityDataStream/AveragedDailyLoad	Average Daily Load	5	800
ElectricityDataStream/DataStreamType	Type	C	I
ElectricityDataStream/ProfileName	Profile Name	NSLP	NOPROF
FromDate	Start Date	31-12-2001	01-06-2005
ToDate	End Date	31-12-9999	31-12-9999
MaintenanceDate	Updated On	02-01-2004 13:27:58	31-12-9999
CreationDate	Created On	19-01-2002 17:15:23	05-06-2005 15:12:20
RowStatus	Activity Status	I	A

9. CATS_Register_Identifier

9.1. Field Definitions

The CATS_Register_Identifier table contains data that is stored at the register identifier level. Information stored at this level includes the Network Tariff Code. It is updated whenever a Change Request containing inbound register identifier data is completed.

Note: References to 'LNSP' include the ENM for *child connection points*.

Table 18 CATS_REGISTER_IDENTIFIER – Field Definitions

Data Element Name	Description	Standing Data Required	Party to Provide
NMI	<i>NMI</i> . This number is unique for each <i>connection point</i> within the NEM.	MANDATORY	MPB
SerialNumber	The Meter Serial ID uniquely identifies a <i>meter</i> for a given <i>NMI</i> . Maximum 12 Characters (alpha numeric). Unique for <i>NMI</i> . Use dummy for UMCP (Type 7), logical (<i>meters</i>) and <i>non-contestable unmetered loads</i> . Except for UMCP, logical, and <i>non-contestable unmetered loads</i> , MeterSerial should be displayed on physical device also known as property number). SerialNumber to be property number if exists, otherwise the <i>meter</i> manufacturers' serial number, otherwise dummy number.	MANDATORY	MPB
RegisterID	The RegisterID is used to identify a data source that is obtained from the <i>meter</i> . A single <i>meter</i> may provide multiple data sources.	MANDATORY	MPB
NetworkTariffCode	The Network Tariff Code is a free text field required. The text must match the Network Tariff Codes supplied and published by the LNSP. Must be a valid code from the CATS_Network_Tariff_Codes table.	MANDATORY	MPB
NetworkAdditional Information	Free text field.	REQUIRED	MPB
UnitOfMeasure	Code to identify the unit of measure for data held in this register.	MANDATORY	MPB

Data Element Name	Description	Standing Data Required	Party to Provide
TimeOfDay	Code to identify the time validity of register contents. As published by each LNSP. This value must correspond to a valid Time of Day value in the Time of Day Codes reference table listed in section 11. For Interval meters, use code "INTERVAL".	MANDATORY	MPB
Multiplier	Multiplier required to take a register value and turn it into a value representing billable energy	MANDATORY	MPB
DialFormat	Describes the register display format. First number is the number of digits to the left of the decimal place, and the second number is the number of digits to the right of the decimal place.	MANDATORY	MPB
Suffix	The Suffix field in the CATS_REGISTER_IDENTIFIER table is used to identify a physical data source that is obtained from the <i>meter</i> . The value must match the value provided in the MDF File. The Suffix value must be unique for each meter register. The Suffix in the CATS_REGISTER_IDENTIFIER table must be valid as per Datastream suffix details specified in the NMI Procedure. <ul style="list-style-type: none"> For Basic Meters, the Suffix in the CATS_REGISTER_IDENTIFIER table need not match the RegisterID in the CATS_REGISTER_IDENTIFIER table. For basic data streams, the value will be identical to the related Suffix value in the CATS_NMI_DataStream table. For Interval Meters, the Suffix in the CATS_REGISTER_IDENTIFIER table will indicate the individual datastreams: <ul style="list-style-type: none"> contributing to the Nx Suffix value in the CATS_NMI_DataStream table, or associated with the individual register level interval datastream records. 	MANDATORY	MPB
ControlledLoad	Indicates whether the <i>energy</i> recorded by this register is created under a Controlled Load regime ControlledLoad field will have "NO" if register does not relate to a Controlled Load. If the register relates to a Controlled Load, it must correspond to a valid Controlled Load value in the Controlled Load Codes reference table listed in section 11.	MANDATORY	MPB
RegisterDetail/ Status	Lookup code to indicate if register is active. Must ensure that RegisterDetail/Status is not Current (C) when ElectricityMeter/Status is Removed (R). This value must correspond to a valid Register Identifier Status as specified in the MSATS Procedures: Principles and Obligations for all Connection PointsGATS Procedures .	MANDATORY	MPB

Data Element Name	Description	Standing Data Required	Party to Provide
ConsumptionType	<p>Actual/Subtractive Indicator.</p> <p>Actual (A) implies volume of energy actually metered between two dates.</p> <p>Cumulative (C) indicates a Meter Reading for a specific date. A second Meter Reading is required to determine the consumption between those two Meter Reading dates.</p> <p>For an Interval Meter, ActCumInd = A.</p> <p>This value must correspond to a valid ConsumptionType from the Consumption Type Codes reference table listed in section 11.</p>	MANDATORY	MPB
FromDate	<p>Start date of the <i>NMI</i> data record. This indicates the date on which the parameters of this particular <i>NMI</i> data record apply from.</p> <p>The data applies from the beginning of this date (the start of the day, i.e. 00:00).</p>	MANDATORY	Participant sending transaction
ToDate	<p>End date of the record. This indicates the date on which the parameters of this particular record end. The data applies until the end of this date (the end of the day, i.e. 23:59).</p> <p>A default date of 9999-12-31 is recorded if EndDate is not provided.</p>	MANDATORY (Defaults to high date unless supplied)	System generated unless supplied.
RowStatus	<p>Indicates whether the record is active or inactive.</p> <p>Whenever a new record is created, it will be A (Active). A change to the data will make this record redundant and its MaintActFlg is changed to I (Inactive).</p>	MANDATORY	System generated
MaintenanceDate	<p>Date and time the record was updated.</p> <p>A default date of 9999-12-31 is used when the record is created initially.</p> <p>If the record is subsequently updated, its MaintUpdtDt is changed to the date and time the record was updated.</p>	MANDATORY	System generated
CreationDate	Date and time the record was created.	MANDATORY	System generated

9.2. Cross Reference of Browser and aseXML Data Elements

The table below lists the names that are used in the MSATS browser. The table also provides the aseXML data element names and the respective formats used in each context.

In some cases, such as date fields, the format of the field is shown differently in the Browser to that used in the related aseXML transactions. Also, aseXML uses full words throughout, rather than the coded values used in the Browser.

Section 16 provides data type conventions of the Browser formats shown in this section.

Table 19 CATS_Register_Identifier - Browser Cross Reference

Browser Field Name	aseXML Data Element Name	aseXML Path	Browser Format	aseXML Data Type
NMI	NMI	NMI	CHAR(10)	xsd:string maxLen = 10
Meter Serial ID Meter ID (Different on two screens)	SerialNumber	SerialNumber	VARCHAR2(12)	xsd:string maxLen = 12
Register ID	RegisterID	ElectricityMeterRegisterDetail/RegisterID	VARCHAR2(10)	xsd:string maxLen = 10
Network Tariff Code	NetworkTariffCode	ElectricityMeterRegisterDetail/NetworkTariffCode	VARCHAR2(10)	xsd:string maxLen = 10
Network Tariff Additional Information	NetworkAdditionalInformation	ElectricityMeterRegisterDetail/NetworkAdditionalInformation	VARCHAR2(4000)	xsd:string
Unit of Measure	UnitOfMeasure	ElectricityMeterRegisterDetail/UnitOfMeasure	VARCHAR2(5)	xsd:string maxLen = 5
Time of Day	TimeOfDay	ElectricityMeterRegisterDetail/TimeOfDay	VARCHAR2(10)	xsd:string maxLen = 10
Multiplier	Multiplier	ElectricityMeterRegisterDetail/Multiplier	Number(13,5)	xsd:decimal
Dial Format	DialFormat	ElectricityMeterRegisterDetail/DialFormat	Number(4,2)	xsd:decimal minIncl = 0 maxIncl = 9999.99

Browser Field Name	aseXML Data Element Name	aseXML Path	Browser Format	aseXML Data Type
				totalDigits = 4 fractionDigits = 2
Suffix	Suffix	ElectricityMeterRegisterDetail/Suffix	VARCHAR2(2)	xsd:string maxLength = 2
Controlled Load	ControlledLoad	ElectricityMeterRegisterDetail/ControlledLoad	VARCHAR2(100)	xsd:string maxLength = 100
Status Code	Status	ElectricityMeterRegisterDetail/Status	CHAR(1)	xsd:string with enumeration
Actual/Cumulative Indicator	ConsumptionType	ElectricityMeterRegisterDetail/ConsumptionType	CHAR(1)	xsd:string with enumeration
Start Date	FromDate	FromDate	dd-mmm-yyyy	xsd:dateTime
End Date	ToDate	ToDate	dd-mmm-yyyy	xsd:dateTime
Updated On	MaintenanceDate	MaintenanceDate	dd-mmm-yyyy (summary screen) dd-mmm-yyyy hh:mm:ss (detail screen)	xsd:dateTime
Created On	CreationDate	CreationDate	dd-mmm-yyyy (summary screen) dd-mmm-yyyy hh:mm:ss (detail screen)	xsd:dateTime
Activity Status	RowStatus	RowStatus	CHAR(1)	xsd:string with enumeration

9.3. Field value examples

This section provides examples of typical sets of data element values associated with different types of *connection points*.

The data shown in each example is as shown in the Browser. This reverses the sequence of the day-month-year communicated via aseXML transactions.

Table 20 CATS_Register_Identifier - Example

Data Element Name	Browser Field Name	Basic Example	Interval Example
NMI	NMI	1100445566	2211335544
SerialNumber	Meter Serial ID Meter ID (Different on two screens)	000012345	112258
RegisterID	Register ID	1	E1
NetworkTariffCode	Network Tariff Code	BLNB2CO	MB2RI
NetworkAdditionalInformation	Network Tariff Additional Information	General Supply Non TOU Eligible	LV TOU Demand Eligible
UnitOfMeasure	Unit of Measure	KWH	KWH
TimeOfDay	Time of Day	ALLDAY	INTERVAL
Multiplier	Multiplier	1.00000	120.00000
DialFormat	Dial Format	5.00	5.10
Suffix	Suffix	11	E1
ControlledLoad	Controlled Load	YES	NO
Status	Status Code	C	C
ConsumptionType	Actual/Cumulative Indicator	C	A
FromDate	Start Date	01-08-2004	01-06-2005
ToDate	End Date	31-12-9999	31-12-9999
MaintenanceDate	Updated On	31-12-9999	31-12-9999
CreationDate	Created On	01-11-2005 22:30:30	05-06-2005 09:09:09
RowStatus	Activity Status	A	A

10. CATS_NMI_PARTICIPANT_RELATIONS

10.1. Field Definitions

The CATS_NMI_Participant_Relations table is a NMI master table containing data that stores the Roles that Participants play for each *NMI*. It is updated whenever a Change Request containing inbound Roles is completed. Each Role record, which contains a single Role code and a single Participant ID, has a start date and an end date, as well as information about when it was created and when it became inactive if it is no longer an active record.

Note: References to 'LNSP' include the ENM for *child connection points*.

Table 21 CATS_NMI_PARTICIPANT_RELATIONS – Field Definitions

Data Element Name	Description	Standing Data Required	Party to Provide
Party	The Participant ID whose relationship (Role) with the <i>NMI</i> is defined in this table.	MANDATORY	LNSP
NMI	<i>NMI</i> . This number is unique for each <i>connection point</i> .	MANDATORY	LNSP
Role	This defines the relationship (Role) of the Participant with the <i>NMI</i> in this table.	MANDATORY	LNSP
FromDate	Start date of the record. This indicates the date on which the parameters of this particular record apply from. The data applies from the beginning of this date (the start of the day, i.e. 00:00).	MANDATORY	Party sending transaction
ToDate	End date of the record. This indicates the date on which the parameters of this particular record end. The data applies until the end of this date (the end of the day, i.e. 23:59). A default date of 9999-12-31 is recorded if EndDate is not provided.	MANDATORY (Defaults to high date unless supplied)	System generated unless supplied.
RowStatus	Indicates whether the record is active or inactive. Whenever a new record is created, it will be A (Active). A change to the data will make this record redundant and its MaintActFlg is changed to I (Inactive).	MANDATORY	System generated

Data Element Name	Description	Standing Data Required	Party to Provide
MaintenanceDate	Date and time the record was updated. A default date of 9999-12-31 is used when the record is created initially. If the record is subsequently updated, its MaintUpdtDt is changed to the date and time the record was updated.	MANDATORY	System generated
CreationDate	Date and time the record was created.	MANDATORY	System generated

10.2. Cross Reference of Browser and aseXML Data Elements

The table below lists the names that are used in the MSATS browser. The table also provides the aseXML data element names and the respective formats used in each context.

In some cases, such as date fields, the format of the field is shown differently in the Browser to that used in the related aseXML transactions. Also, aseXML uses full words throughout, rather than the coded values used in the Browser.

Section 16 provides data type conventions of the Browser formats shown in this section.

Table 22 CATS_NMI_Participant_Relations - Browser Cross Reference

Browser Field Name	aseXML Data Element Name	aseXML Path	Browser Format	aseXML Data Type
Participant ID	Party	Party	VARCHAR2(10)	xsd:string
NMI	NMI	NMI	CHAR(10)	xsd:string maxLen = 10
Role	Role	Role	VARCHAR2(4)	xsd:string maxLen = 4
Start Date	FromDate	FromDate	dd-mmm-yyyy	xsd:dateTime
End Date	ToDate	ToDate	dd-mmm-yyyy	xsd:dateTime
Updated On	MaintenanceDate	MaintenanceDate	dd-mmm-yyyy (summary screen) dd-mmm-yyyy hh:mm:ss (detail screen)	xsd:dateTime

Browser Field Name	aseXML Data Element Name	aseXML Path	Browser Format	aseXML Data Type
Created On	CreationDate	CreationDate	dd-mmm-yyyy (summary screen) dd-mmm-yyyy hh:mm:ss (detail screen)	xsd:dateTime
Activity Status	RowStatus	RowStatus	CHAR(1)	xsd:string with enumeration

11. Reference tables

Table 23 - Valid Aggregate Codes

Aggregate	Description
Y	Customer load.
N	Generator NMI.

Table 24 - Valid Consumption Type Codes

Consumptiontype	Description
ACTUAL	Actual Consumption.
CUMULATIVE	Cumulative Consumption.

Table 25 - Valid Datastream Type Codes

Datastreamtype	Description	Datastream suffix (as per NMI Procedure)
I	Interval Datastream included in NEM Settlement process.	A, D, B, E, N
C	Consumption Datastream is included in NEM Settlement Process.	First character is 1 to 9
P	Profile Datastream included in NEM Profile calculations (Sample meters only).	E, N
N	Interval Datastream is not to be included in the NEM Settlement process or NEM Profile calculations.	J, P, S, K, Q, T, G, H, M, V, C, F, L, R, U, Y, W, Z, X A,D,B,E when not used for NEM Settlements (e.g. Vic TUOS)

Table 26 - Valid Profile Codes

ProfileName	Description
NSLP	Net System Load Profile. The profile is calculated by MSATS. NSLP represents the system load after all actual <i>interval metering data</i> or specified previously-calculated profiled <i>metering data</i> that is not dependent on the NSLP has been subtracted from a known total system load and represents system-wide usage by consumption-type <i>metering installations</i> .
QLDEGXCL31	Controlled Load profile Energex tariff 31
QLDEGXCL33	Controlled Load profile Energex tariff 33
SACLOAD	South Australian Controlled Load.
NOPROF	Used for interval Datastream types (to indicate that such Datastreams do not need to be profiled to obtain 'readings' for each <i>settlements</i> interval because the data is supplied in 30-minute intervals).

Table 27 Valid Transformer Fields values

Valid Transformer Fields values can be found at the following location:

[https://visualisations.aemo.com.au/aemo/web-help/Content/MSATSuserGuides/UpdateMeteringData.htm?TocPath=Market%20Settlement%20and%20Transfer%20System%20\(MSATS\)%7CGuide%20to%20MSATS%7CMetering%20Data%7C_4](https://visualisations.aemo.com.au/aemo/web-help/Content/MSATSuserGuides/UpdateMeteringData.htm?TocPath=Market%20Settlement%20and%20Transfer%20System%20(MSATS)%7CGuide%20to%20MSATS%7CMetering%20Data%7C_4)

Proposed changes to Transformer Field values must be submitted to AEMO via the Electricity Retail Consultative Forum's Issue/Change Form. Once a request has been received and verified, AEMO will notify stakeholders of the proposed changes and applicable effective date.

Table 28 Valid Meter Use Codes

Meter Use	Description
REVENUE	Revenue meter. or unmetered load.

Meter Use	Description
CHECK	Check meter.
STATIS	Statistical meter.
TUOS	TUOS meter.
LOGICAL	Logical meter.
SAMPLE	Sample meter.
AVERAGE	Average meter.
PREPAID	Prepaid meter.
INFORM	Information meter.
UNKNOWN	Unknown meter use code.

Table 29 Valid Time of Day Codes

TimeOfDay	Description
ALLDAY	All day
INTERVAL	Interval time of day, used for all Interval metering
PEAK	Peak time of day
BUSINESS	Business time of day
SHOULDER	Shoulder time of day
EVENING	Evening time of day
OFFPEAK	Off peak time of day
CONTROLLED	Controlled time of day
DEMAND	Demand is used for describing a register

Table 30 Valid Controlled Load Codes

ControlledLoad	Description
NO	No controlled load
YES	There is controlled load associated with a controlled load network tariff on this register
EXT	There is controlled load which is externally switched by the LNSP associated with a controlled load network tariff on this register

Table 31 Valid Test Result Codes

Test Result	Description
PASS	Test has passed
FAIL	Test has failed

Table 32 Valid Transformer Test Values

Test Result	Description
TESTED	Part of 100% testing
SAMPLE TESTED	Tested as part of a sample plan
SAMPLE	Part of an approved sample plan

Table 33 Valid Shared Isolation Point Flag Values

SharedIsolationPointFlag	Description
Y	Indicates that a Shared Fuse Arrangement is present

SharedIsolationPointFlag	Description
N	Indicates that no Shared Fuse Arrangement is present
I	Indicates the metering installation is Isolated independently but still part of a Shared Fuse Arrangement
U	Indicates that the presence of a Shared Fuse Arrangement is Unknown

Note: Refer to the MSATS [Procedures: Principles and Obligations for all Connection Points](#) ~~CATS Procedure~~ section 4 for details on the valid codes for the following:

- Jurisdiction Codes
- Metering Installation Type Codes
- NMI Classification Codes
- NMI Status Codes
- Datastream Status Codes

12. Use of NMI suffix to populate CATS_REGISTER_IDENTIFIER

For any particular *connection point* there may be multiple *energy* measurement elements and data recorders with multiple channels. Accurate identification of Datastreams is essential.

The NMI Procedure includes the requirements for structure of both the Suffix populated in the CATS_REGISTER_IDENTIFIER table and the ElectricityDataStream Suffix populated in the CATS_DATA_STREAM table.

The illustrations below provide context to the relationships between ‘Suffix’ across the MDFF Specification and [CATSMSATS Procedures: Principles and Obligations for all Connection Points](#) (specifically the CATS_REGISTER_IDENTIFIER table and CATS_DATA_STREAM tables).

Example of an Accumulated Meter ‘Suffix’

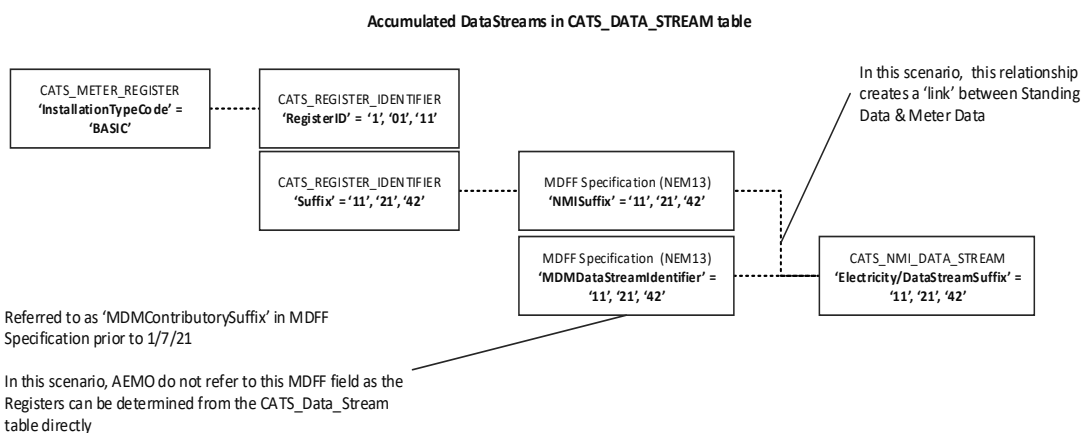

Example of an Interval Meter ‘Suffix’ – Net DataStreams

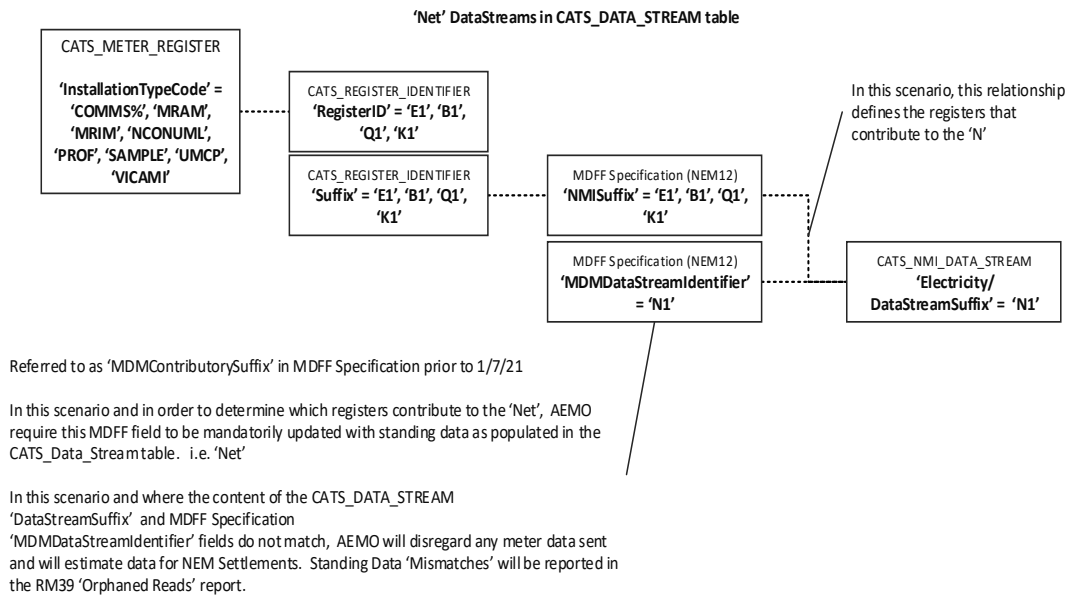

Example of an Interval Meter “Suffix” – Register Level DataStreams

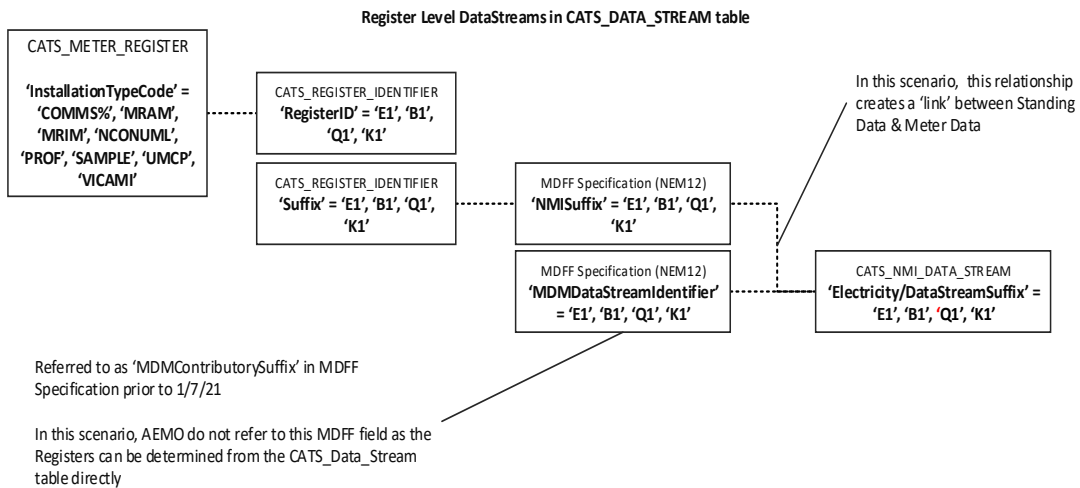

Note:

- A record must be created in the CATS_REGISTER_TABLE for each register required for settlements, profiling and UFE calculations.
- An ElectricityDataStream Suffix must be created for all individual DataStreams required for NEM Settlement calculations, profile peeloff, UFE analysis and Vic TUOS sites.

The NMI Procedure includes the requirements for the use of a suffix to the *NMI* that identifies these Datastreams. The DataStreamSuffix detailed in the NMI Procedure provides identification at the measurement element level for all Datastreams from the *connection point* identified by the *NMI*. The DataStreamSuffix is commonly known as the NMISSuffix. The NMISSuffix is labelled as 'Suffix' in the Browser and is the ElectricityDataStream/Suffix data element in aseXML.

12.1. Historical Information and Guideline only

The NMISuffix was first used in the NMI Procedure to describe, in conjunction with the *NMI*, the data transferred from the MDP to AEMO and Participants for *settlements*. The NMISuffix was further extended to describe Datastreams in MSATS, and numeric suffixes were developed to describe the data from type 6 *metering installations*.

In MSATS, the NMISuffix is used in the CATS_NMI_DATA_STREAM table to describe the data as delivered to AEMO. For *settlements* purposes this data must be 'NET' [Export from *network*, less import to *network*] and will be 'Nx' for an interval Datastream, or numeric for an Accumulation Meter.

In MSATS release 2.0 a new table, CATS_REGISTER_IDENTIFIER, was introduced to link identifiers for the source *meter* register(s) to the Datastream suffix in the CATS_NMI_DATA_STREAM table. The purpose of the table is to enable the alignment of the data held in MSATS and the data being transferred between Participants in the B2B process.

This link is achieved through the RegisterID (which describes the data source at the *metering installation*) and ElectricityDataStream/Suffix (which describes the NMISuffix to which the RegisterID contributes) data elements. This is a many-to-one relationship, i.e. there may be multiple RegisterID values for each ElectricityDataStream/Suffix value in the CATS_REGISTER_IDENTIFIER table.

- The RegisterID identifies the measurement element and type of measurement for an Interval Meter, and identifies the location of a stored energy value in an Accumulation Meter.
- The ElectricityDataStream/Suffix value in the CATS_NMI_DATA_STREAM table identifies the Datastream registered in MSATS. For *settlements* purposes, Interval Meter Datastreams will be the NET suffix (format Nx) and for Accumulation Meter Datastreams the suffix value is numeric. MSATS requires data to be delivered against this suffix (if the Datastream is ACTIVE). MSATS does not validate the values entered in this field.
- The ElectricityDataStream/Suffix value in the CATS_REGISTER_IDENTIFIER table identifies the individual Datastream(s) contributing to the ElectricityDataStream/Suffix value in the CATS_NMI_DATA_STREAM table. For interval Datastreams, the suffix(es) will indicate the individual Datastream(s) contributing to the Nx Suffix value in the CATS_NMI_DATA_STREAM table where the DataStreamType is P or I (Refer section 14 for examples). For accumulation Datastreams the value will be numeric and will be identical to the related Suffix value in the CATS_NMI_DATA_STREAM table (refer section 13 for examples).
- The ElectricityDataStream/Suffix values used in the CATS_REGISTER_IDENTIFIER table are used to identify *metering data* contained in MDFF Files (in the NMISuffix field).
- The linkage between the RegisterID and ElectricityDataStream/Suffix exists because the ElectricityDataStream/Suffix data element is populated in the CATS_REGISTER_IDENTIFIER table.
- The RegisterID data element has no standard format; therefore, the MPB must determine the appropriate population of this field, e.g. it may be used to indicate the programming code of the register.

There is an inconsistent understanding across industry of the meaning of the terms 'register' and 'datastream'. Conventionally, to field metering personnel, a 'register' contains a single value, while a 'datastream' represents an array of time separated register values in chronological order.

For Accumulation Meters, the RegisterID refers to the non-volatile storage of the cumulative energy register(s). The RegisterID will have identification with the displays of the *meters*, or identification of internal data stores.

For Accumulation Meters, the ElectricityDataStream/Suffix data element in the CATS_REGISTER_IDENTIFIER table may have a many-to-one relationship with the ElectricityDataStream/Suffix data element in the CATS_NMI_DATA_STREAM table. That is, the same Suffix may occur several times in the CATS_REGISTER_IDENTIFIER table and occur once only in the CATS_NMI_DATA_STREAM table.

For Interval Meters, the definition of the RegisterID field is less obvious. To make this field useful, the RegisterID should be associated with the ElectricityDataStream/Suffix. As Interval Meters may have multiple measurement elements and there may be multiple *meters* for a *NMI*, the MDP must manage Datastreams against a *NMI* to avoid duplication of ElectricityDataStream/Suffixes and provide correct mapping of RegisterIDs.

13. Assignment of data – ACCUMULATION meters

This section details examples of the assignment of data for various basic *metering installations*. For Accumulation Meters, the Suffix values in CATS_REGISTER_IDENTIFIER and CATS_NMI_DATA_STREAM tables are always numeric.

13.1. Single Meter, no controlled load

A Accumulation Meter with a single register measuring a Non-Controlled Load will have a single Datastream suffix 11 for the *NMI*.

Table 34 Example CATS_NMI_DATA_STREAM

Data Element:	NMI	Suffix	ElectricityDataStream/Status	DataStreamType
Value	0123456789	11	A	C

The CATS_REGISTER_IDENTIFIER table indicates that the *meter* has only one register. The Suffix in the CATS_REGISTER_IDENTIFIER ‘11’ denotes that data from RegisterID 01 contributes to the Datastream identified by Suffix 11 in CATS_NMI_DATA_STREAM table.

Table 35 Example CATS_REGISTER_IDENTIFIER

Data Element:	Serial Number	RegisterID	UnitOfMeasure	TimeOfDay	Suffix	Controlled Load
Value	ABCD1111	01	KWH	ALLDAY	11	NO

The ElectricityDataStream Suffix in CATS_NMI_DATA_STREAM table will be recorded as ‘11’ by the MDP and the Suffix in CATS_REGISTER_IDENTIFIER table must then be ‘11’.

13.2. Two Single Element Meters, no controlled load

The *NMI* has two Accumulation Meters, each *meter* with single register. The data from the two *meters* will be submitted to MSATS as two Datastreams.

Table 36 Example CATS_NMI_DATA_STREAM

Data Element:	NMI	Suffix	ElectricityDataStream/Status	DataStreamType
Values	0123456789	11	A	C
	0123456789	12	A	C

Table 37 Example CATS_REGISTER_IDENTIFIER

Data Element:	Serial Number	RegisterID	UnitOfMeasure	TimeOfDay	Suffix	Controlled Load
Values	ABCD1111	01	KWH	ALLDAY	11	NO
	XYZA1112	01	KWH	ALLDAY	12	NO

13.3. Two Single Element Meters, one with controlled load

A *NMI* has two Accumulation Meters, each *meter* has a single register, and one *meter* is measuring a Controlled Load. The data from the two *meters* is submitted to MSATS as two ElectricityDataStream Suffixes.

Table 38 Example CATS_NMI_DATA_STREAM

Data Element:	NMI	Suffix	ElectricityDataStream/Status	DataStreamType
Value	0123456789	11	A	C
	0123456789	42	A	C

Table 39 Example CATS_REGISTER_IDENTIFIER

Data Element:	Serial Number	RegisterID	UnitOfMeasure	TimeOfDay	Suffix	Controlled Load
Values	ABCD1111	01	KWH	ALLDAY	11	NO
	XYZA1112	01	KWH	CONTROLLED	42	EXT

13.4. One Meter with Two Registers, one measuring a controlled load

NMI has one Accumulation Meter with two registers. The second register is measuring a Controlled Load.

Table 40 Example CATS_NMI_DATA_STREAM

Data Element:	NMI	Suffix	ElectricityDataStream/Status	DataStreamType
Value	0123456789	11	A	C
	0123456789	42	A	C

Table 41 Example CATS_REGISTER_IDENTIFIER

Data Element:	Serial Number	RegisterID	UnitOfMeasure	TimeOfDay	Suffix	Controlled Load
Value	ABCD1111	01	KWH	PEAK	11	NO
	ABCD1111	02	KWH	CONTROLLED	41	YES

13.5. Single Multi-function Meter

Accumulation Meter has 4 registers, one register being a Controlled Load.

Table 42 Example CATS_NMI_DATA_STREAM

Data Element:	NMI	Suffix	ElectricityDataStream/Status	DataStreamType
Values	0123456789	11	A	C
	0123456789	21	I	C
	0123456789	31	A	C
	0123456789	41	A	C

Each register is separately identified in CATS_NMI_Data_Stream. However, register 2 on meter 1 is inactive in MSATS.

Table 43 Example CATS_REGISTER_IDENTIFIER

Data Element:	Serial Number	RegisterID	UnitOfMeasure	TimeOfDay	Suffix	Controlled Load
Values	ABCD1111	01	KWH	PEAK	11	NO
	ABCD1111	02	KWH	SHOULDER	21	NO
	ABCD1111	03	KWH	OFFPEAK	31	NO
	ABCD1111	04	KWH	CONTROLLED	41	YES

13.6. Two meters, three registers. One register measures a controlled load

Table 44 Example CATS_NMI_DATA_STREAM

Data Element:	NMI	Suffix	ElectricityDataStream/Status	DataStreamType
Values	0123456789	11	A	C
	0123456789	21	A	C
	0123456789	42	A	C

Table 45 Example CATS_REGISTER_IDENTIFIER

Data Element:	Serial Number	RegisterID	UnitOfMeasure	TimeOfDay	Suffix	Controlled Load
Values	ABCD1111	01	KWH	PEAK	11	NO
	ABCD1111	02	KWH	OFFPEAK	21	NO
	XYZA1112	01	KWH	CONTROLLED	42	EXT

14. Assignment of data – interval meters

This section details examples of the assignment of data for various Interval Meters.

14.1. One meter

Table 46 Example CATS_NMI_DATA_STREAM

Data Element:	NMI	Suffix	ElectricityDataStream/Status	DataStreamType
Value	0123456789	E1	A	I

The CATS_Register_Identifier table indicates that the *meter* has only one register. The Suffix in the CATS_REGISTER_IDENTIFIER [E1] denotes that data from RegisterID 01 contributes to the ElectricityDataStream Suffix identified by Suffix E1 in the CATS_NMI_DATA_STREAM table.

Table 47 Example CATS_REGISTER_IDENTIFIER

Data Element:	Serial Number	RegisterID	UnitOfMeasure	TimeOfDay	Suffix
Value	ABCD1111	01	KWH	INTERVAL	E1

E1 indicates that it is a single element measuring export.

14.2. Import/Export meter

Interval Meter has a two registers, registering import and export *energy*. Multiple ElectricityDataStream Suffixes (E1 and B1) are defined for the *NMI*.

Table 48 Example CATS_NMI_DATA_STREAM

Data Element:	NMI	Suffix	ElectricityDataStream/Status	DataStreamType
Value	0123456789	E1	A	I
Value	0123456789	B1	A	I

The CATS_REGISTER_IDENTIFIER table indicates that the *meter* has two registers, one for IMPORT and one for EXPORT.

Table 49 Example CATS_REGISTER_IDENTIFIER

Data Element:	Serial Number	RegisterID	UnitOfMeasure	TimeOfDay	Suffix
Values	ABCD1111	E1	KWH	INTERVAL	E1
	ABCD1111	B1	KWH	INTERVAL	B1

Only one RegisterID with the Suffix ‘E1’ permitted per *meter* in CATS_REGISTER_IDENTIFIER.

Only one RegisterID with the Suffix ‘B1’ permitted per *meter* in CATS_REGISTER_IDENTIFIER.

14.3. One meter: multiple registers

Interval Meter has a single measurement element registering import and export *energy*, reactive and *voltage*.

Table 50 Example CATS_NMI_DATA_STREAM

Data Element:	NMI	Suffix	ElectricityDataStream/Status	DataStreamType
Value	0123456789	E1	A	I
Value	0123456789	B1	A	I
Value	0123456789	Q1	A	N
Value	0123456789	K1	A	N

The CATS_Register_Identifier table indicates that the *meter* has five registers: two for IMPORT of *energy* and reactive; two for EXPORT of *energy* and reactive; and one for *voltage* monitoring.

Data Element:	Serial Number	RegisterID	UnitOfMeasure	TimeOfDay	Suffix
Values	ABCD1111	E1	KWH	INTERVAL	E1
	ABCD1111	B1	KWH	INTERVAL	B1
	ABCD1111	Q1	KVARH	INTERVAL	Q1
	ABCD1111	K1	KVARH	INTERVAL	K1
	ABCD1111	V1	VOLTS	INTERVAL	V1

14.4. One meter: Twin Measurement Elements

Certain multifunction *meters* have the capability for initial installation as an Accumulation Meter, but can be re-programmed to provide *interval metering data*.

The NER do not permit the use of two different types of *metering installation* on the one *NMI*, and therefore these two *metering* functions MUST NOT be active simultaneously in MSATS.

The MDP and RP will be held accountable for a breach of this requirement.

The CATS_REGISTER_IDENTIFIER can be used to record the *meter* capability.

The CATS_REGISTER_IDENTIFIER table values for this *meter* when it is operated as an Interval Meter are shown below. The RegisterID for the Accumulation Meter registers in this type of *meter* are user defined. The Interval Meter suffixes must be added to the *NMI* and made active, and the basic Suffixes made inactive at the same date.

Table 51 Example CATS_NMI_DATA_STREAM

Data Element:	NMI	Suffix	ElectricityDataStream/Status	DataStreamType
Values	0123456789	E1	A	I
	0123456789	E2	A	I
	0123456789	11	I	C
	0123456789	21	I	C
	0123456789	31	I	C
	0123456789	41	I	C

Table 52 Example CATS_REGISTER_IDENTIFIER

Data Element:	Serial Number	RegisterID	UnitOfMeasure	TimeOfDay	Suffix
Values	AB888888	E1	KWH	INTERVAL	E1
	AB888888	E2	KWH	INTERVAL	E2

Data Element:	Serial Number	RegisterID	UnitOfMeasure	TimeOfDay	Suffix
	AB888888	11	KWH	PEAK	11
	AB888888	21	KWH	SHOULDER	21
	AB888888	31	KWH	OFFPEAK	31
	AB888888	41	KWH	CONTROLLED	41

If a second *meter* of the same configuration were established on this *NMI*, ‘E3’ and ‘E4’ RegisterIDs in the CATS_REGISTER_IDENTIFIER table and ElectricityDataStream Suffixes in the CATS_DATA_STREAM table would be required in order to provide unambiguous identification of Datastreams.

14.5. NCONUML and UMCP

Table 53 Example CATS_NMI_DATA_STREAM

Data Element:	NMI	Suffix	ElectricityDataStream/Status	DataStreamType
Values	1144885588	E1	A	I

Table 54 Example CATS_REGISTER_IDENTIFIER

Data Element:	Serial Number	RegisterID	UnitOfMeasure	TimeOfDay	Suffix
Values	Dummy Value	E1	KWH	INTERVAL	E1

15. Assignments of data – sample meters

The application of profiles in accordance with the Metrology Procedure requires *interval metering data* from Sites that have Accumulation Metering. However, the NER do not permit different metering installation types on the one *NMI*, and in any case, the Participants associated with the *interval metering data* are different to those associated with the Accumulation Meter. Therefore, for these *connection points*, two different *NMIs* are used.

There are *meters* that can combine the required Accumulation Metering and Interval Metering functions. An example is shown below.

15.1. Multifunction Sample Meter

In this case, a single *meter* is registered within MSATS for two purposes against two *NMIs*. This is a special case, and should not be used other than for this non-standard purpose. The *meter* has two circuits, with Accumulation Metering for *energy* trading and Interval Metering for the sample profile.

In this example, NMI 9801234567 is associated with the sample *meter installation* and NMI 9876543210 with the End User installation.

Table 55 Example CATS_NMI_DATA_STREAM

Data Element:	NMI	Suffix	ElectricityDataStream/Status	DataStreamType
Values	9801234567	E1	A	P
	9876543210	11	I	C
	9876543210	12	I	C
	9876543210	41	A	C

Table 56 Example CATS_REGISTER_IDENTIFIER

Data Element:	NMI	MeterSerial	RegisterID	UnitOfMeasure	TimeOfDay	Suffix
Values	9801234567	AB888888	E1	KWH	INTERVAL	E1
	9876543210	AB888888	11	KWH	PEAK	11
	9876543210	AB888888	12	KWH	OFFPEAK	12
	9876543210	AB888888	41	KWH	CONTROLLED	41

16. Data type conventions

The Browser formats used in section 16 are as defined in the following table.

The value of “x” must be positive and cannot be zero.

For explanation of the aseXML data types shown in section 16 refer

<http://www.w3.org/TR/xmlschema-0/#simpleTypesTable>

Table 57 BROWSER FORMATS

	Format	Definition
1	CHAR(x)	Indicates a field that can only contain alphanumeric characters and must contain exactly "x" characters. Note that leading and trailing "spaces" are considered significant (i.e. form part of the "x" characters for the field).
2	VARCHAR2(x)	Indicates a character field containing up to "x" characters.
3	NUMBER(x)	Indicates a positive integer (zero or above) up to "x" significant digits long; any leading zeroes are not significant and hence "050" is equivalent to "50".
4	NUMBER(x.y)	Indicates a positive number with up to "x" significant characters to the left of the decimal point and "y" decimal places after the decimal point (trailing zeros are optional). In other words, the maximum length of the field as a whole is "x"+"y"+1 characters (the +1 reserving space for the decimal point).

Version release history

Version	Effective date	Summary of changes
5.9	15 November 2024TBA	Updating Standing Data document as part of the CATS and WIGS procedures amalgamation
5.8	01 September 2024	Removal of NSW Controlled Load Profile
5.71	2 June 2024	Consolidated versions 5.63 and 5.7 of the Standing Data Document for the Retail Electricity Market Procedures June 2024 Consolidation Consultation.
5.7	2 June 2024	Updated for National Electricity Amendment (Integrating energy storage systems into the NEM) Rule 2021
5.63	4 March 2024	Consolidation of v5.62 and v5.61 to reflect the following: <ul style="list-style-type: none"> November 2023 consolidated version v5.61 Metering installation exemption automation changes from v5.62
5.62	4 March 2024	Updated to include changes to the metering installation malfunction exemption fields as part of the meter exemption automation changes.
5.61	1 November 2023	Consolidation of v5.52 and v5.6 to reflect the following: <ul style="list-style-type: none"> Amendments to the Test Result field examples in Table 5 and the replacement of the values list in Table 27 with the relevant website link Consumer Data Right (CDR) Inclusion of LastConsumerChangeDate field
5.6	1 November 2023	Consumer Data Right (CDR) Inclusion of LastConsumerChangeDate field
5.52	29 September 2023	Amendments to the Test Result field examples in Table 5 and the replacement of the values list in Table 27 with the relevant website link
5.51	30 May 2023	Consolidation of v5.35, v5.4, v5.41 and v5.5 <ul style="list-style-type: none"> Addition of CT Ratio (Available) 100/150:1 Addition of CT Ratio (Available) 500/2000/3000:1
5.5	30 May 2023	Updated as part of the Load Profiling Methodologies Consultation to include: ICF_064 Addition of the 'HouseNumberToSuffix' field
5.41	30 May 2023	Removal of Consumer Data Right (CDR) change of LastConsumerChangeDate field from the 30 May 2023 MSATS standing data changes.
5.4	30 May 2023	Consumer Data Right (CDR) · Inclusion of LastConsumerChangeDate field
5.35	17 April 2023	Updated to include additional CT Ratio Available
5.34	1 March 2023	Updated to include: <ul style="list-style-type: none"> Additional VT Ratio Additional CT Ratios Available Additional CT Ratio Connected

Version	Effective date	Summary of changes
5.33	16 December 2022	Updated to include: <ul style="list-style-type: none"> Additional CT Ratio Available enumerations Minor correction in CATS_METER_REGISTER Table 3 of GPS decimals
5.32	7 November 2022	Updated to include new CT Ratios and correct anomalies
5.31	7 November 2022	Updated to include minor amendments as part of the CDR consultation
5.3	7 November 2022	Updated as part of Retail Electricity October consultation. Consolidated V5.11 and v5.2. Updated implementation date for: <ul style="list-style-type: none"> CIP_049 Controlled Load Enumerations CIP_053 GPS Coordinates Minimum Requirements Clarified connection configuration
5.21	7 November 2022	MSATS Standing Data Review Minor Amendment
5.2	N/A	MSATS Standing Data Review Phase 2 – Removed fields Version not used.
5.11	1 May 2022	Updated Controlled Load Enumerations (CIP_049), GPS Coordinates Minimum Requirements (CIP_053) and clarified connection configuration as part of Retail Electricity October 2021 consultation. Consolidated v4.52, v4.6, v5.0 and v5.1.
5.101	1 May 2022	MSATS Standing Data Review Minor Amendment
5.1	1 May 2022	Updated as part of Retail Electricity Market Procedures March 2021 Consultation for ICF_037 Redefinition of ‘Connection Configuration’.
5.0	1 May 2022	Updated to incorporate amendments for National Electricity Amendment (Global Settlement and Market Reconciliation) Rule 2018 No 14.
4.6	20 May 2019	MSATS Standing Data Review Phase 1 – New and amended fields
4.52	1 October 2021	v4.5 and v4.51 consolidation
4.51	1 October 2021	Updated to include changes for the Metering ICF Package 2020 consultation, the changes are for the following Information Change Requests (ICFs): <ul style="list-style-type: none"> ICF_027 Average Daily Load (ADL) definition ICF_029 Amend or Revert Definition of the Register ID Field in MSATS.
4.5	01 October 2021	Updated to incorporate amendments for National Electricity Amendment (Five Minute Settlement) Rule 2017 No. 15 and National Electricity Amendment (Global Settlement and Market Reconciliation) Rule 2018 No 14.
4.4	01 December 2017	Final Version
4.3	01 December 2017	Updated to incorporate: <ul style="list-style-type: none"> National Electricity Amendment (Expanding competition in metering and related services) Rule 2015. No.12;

Version	Effective date	Summary of changes
		<ul style="list-style-type: none"> National Electricity Amendment (Embedded Networks) Rule 2015 No. 15; and National Electricity Amendment (Meter Replacement Processes) Rule 2016 No. 2.
4.2	28/08/2013	Updated wording for Nx suffixes in sections 8, 9 and 12. Updated reference to the CATS procedures for Embedded Networks in section 7. Added new data stream type codes under section 11: Reference Tables. Updated reference to the NEM Metrology Procedures in section 15.
4.1	19/04/2012	Updates to NMI Data tables to include Feeder Class, Customer Classification Code & Customer Threshold Code and minor data corrections.
4.0	Aug 2009	Update to AEMO Format