

STANDING DATA FOR MSATS

PREPARED BY: AEMO MARKETS
VERSION: 5.11
EFFECTIVE DATE: 1 May 2022
STATUS: Final

Approved for distribution and use by:

APPROVED BY: Michael Gatt
TITLE: Executive General Manager Operations

DATE: 27 January 2022

VERSION RELEASE HISTORY

Version	Effective Date	Summary of Changes
4.0	Aug 2009	Update to AEMO Format
4.1	19/04/2012	Updates to NMI Data tables to include Feeder Class, Customer Classification Code & Customer Threshold Code and minor data corrections.
4.2	28/08/2013	Updated wording for Nx suffixes in sections 8, 9 and 12. Updated reference to the CATS procedures for Embedded Networks in section 7. Added new data stream type codes under section 11: Reference Tables. Updated reference to the NEM Metrology Procedures in section 15.
4.3	01 December 2017	Updated to incorporate: <ul style="list-style-type: none"> National Electricity Amendment (Expanding competition in metering and related services) Rule 2015. No.12; National Electricity Amendment (Embedded Networks) Rule 2015 No. 15; and National Electricity Amendment (Meter Replacement Processes) Rule 2016 No. 2.
4.4	01 December 2017	Final Version
4.5	01 October 2021	Updated to incorporate amendments for National Electricity Amendment (Five Minute Settlement) Rule 2017 No. 15 and National Electricity Amendment (Global Settlement and Market Reconciliation) Rule 2018 No 14.
4.51	1 October 2021	Updated to include changes for the Metering ICF Package 2020 consultation, the changes are for the following Information Change Requests (ICFs): <ul style="list-style-type: none"> ICF_027 Average Daily Load (ADL) definition ICF_029 Amend or Revert Definition of the Register ID Field in MSATS.
4.52	1 October 2021	v4.5 and v4.51 consolidation
4.6	20 May 2019	MSATS Standing Data Review Phase 1 – New and amended fields
5.0	1 May 2022	Updated to incorporate amendments for National Electricity Amendment (Global Settlement and Market Reconciliation) Rule 2018 No 14.
5.1	1 May 2022	Updated as part of Retail Electricity Market Procedures March 2021 Consultation for ICF_037 Redefinition of 'Connection Configuration'.
5.101	1 May 2022	MSATS Standing Data Review Minor Amendment
5.11	1 May 2022	Consolidated v4.52, v4.6, v5.0 and v5.1 as part of Retail Electricity October 2021 consultation.

CONTENTS

1.	INTRODUCTION	6
1.1.	Purpose and scope	6
1.2.	Definitions and interpretation	6
1.3.	Related documents	6
2.	BACKGROUND	6
3.	CONVENTIONS USED WITHIN THIS DOCUMENT	7
3.1.	Column Headed: Standing Data Required	7
3.2.	NMIs Affected	7
4.	CATS_METER_REGISTER	9
4.1.	Field Definitions	9
4.2.	Cross Reference of Browser and aseXML Data Elements	13
4.3.	Field value examples	17
5.	CATS_DLF_CODES	19
5.1.	Field Definitions	19
5.2.	Cross Reference of Browser and aseXML Data Elements	21
5.3.	Field value examples	22
6.	CATS_EMB_NET_ID_CODES	23
6.1.	Field Definitions	23
6.2.	Cross Reference of Browser and aseXML Data Elements	25
6.3.	Field value examples	26
7.	CATS_NMI_DATA	27
7.1.	Field Definitions	27
7.2.	Cross Reference of Browser and aseXML Data Elements	31
7.3.	Field value examples	34
8.	CATS_NMI_DATA_STREAM	36
8.1.	Field Definitions	36
8.2.	Cross Reference of Browser and aseXML Data Elements	38
8.3.	Field value examples	39
9.	CATS_REGISTER_IDENTIFIER	41
9.1.	Field Definitions	41
9.2.	Cross Reference of Browser and aseXML Data Elements	44
9.3.	Field value examples	46
10.	CATS_NMI_PARTICIPANT_RELATIONS	47
10.1.	Field Definitions	47
10.2.	Cross Reference of Browser and aseXML Data Elements	48

11.	REFERENCE TABLES	50
12.	USE OF NMI SUFFIX TO POPULATE CATS_REGISTER_IDENTIFIER	52
12.1.	Historical Information and Guideline only	53
13.	ASSIGNMENT OF DATA – ACCUMULATION METERS	54
13.1.	Single Meter, no controlled load	54
13.2.	Two Single Element Meters, no controlled load	55
13.3.	Two Single Element Meters, one with controlled load	55
13.4.	One Meter with Two Registers, one measuring a controlled load	56
13.5.	Single Multi-function Meter	56
13.6.	Two meters, three registers. One register measures a controlled load	57
14.	ASSIGNMENT OF DATA – INTERVAL METERS	57
14.1.	One meter	57
14.2.	Import/Export meter	57
14.3.	One meter: multiple registers	58
14.4.	One meter: Twin Measurement Elements	58
14.5.	NCONUML and UMCP	59
15.	ASSIGNMENTS OF DATA – SAMPLE METERS	60
15.1.	Multifunction Sample Meter	60
16.	DATA TYPE CONVENTIONS	60

TABLES

Table 1	MSATS Master Tables	6
Table 2	Explanation of Standing Data Requirements	7
Table 3	CATS_METER_REGISTER – Field Definitions	9
Table 4	CATS_Meter_Register – Browser Cross Reference.....	14
Table 5	MSATS_Meter_Register – Example	17
Table 6	CATS_DLF_CODES – Field Definitions	20
Table 7	CATS_DLF_Codes - Browser Cross Reference	21
Table 8	CATS_DLF_Codes - Example.....	22
Table 9	CATS_EMB_NET_ID_CODES – Field Definitions	23
Table 10	CATS_Emb_Net_ID_Codes - Browser Cross Reference	25
Table 11	CATS_Emb_Net_ID_Codes - Example	26
Table 12	CATS_NMI_DATA – Field Definitions	27
Table 13	CATS_NMI_Data.....	31
Table 14	CATS_NMI_Data Field value examples.....	35
Table 15	CATS_NMI_DATA_STREAM – Field Definitions.....	37
Table 16	CATS_NMI_DATA_STREAM- Browser cross reference	39
Table 17	CATS_NMI_Data_Stream – Examples.....	40

Table 18 CATS_REGISTER_IDENTIFIER – Field Definitions 41

Table 19 CATS_Register_Identifier - Browser Cross Reference 44

Table 20 CATS_Register_Identifier - Example..... 46

Table 21 CATS_NMI_PARTICIPANT_RELATIONS – Field Definitions..... 48

Table 22 CATS_NMI_Participant_Relations - Browser Cross Reference 49

Table 23 - Valid Aggregate Codes..... 50

Table 24 - Valid Consumption Type Codes..... 50

Table 25 - Valid Datastream Type Codes..... 51

Table 26 - Valid Profile Codes 51

Table 27 Example CATS_NMI_DATA_STREAM 55

Table 28 Example CATS_REGISTER_IDENTIFIER..... 55

Table 29 Example CATS_NMI_DATA_STREAM 55

Table 30 Example CATS_REGISTER_IDENTIFIER..... 55

Table 31 Example CATS_NMI_DATA_STREAM 55

Table 32 Example CATS_REGISTER_IDENTIFIER..... 56

Table 33 Example CATS_NMI_DATA_STREAM 56

Table 34 Example CATS_REGISTER_IDENTIFIER..... 56

Table 35 Example CATS_NMI_DATA_STREAM 56

Table 36 Example CATS_REGISTER_IDENTIFIER..... 56

Table 37 Example CATS_NMI_DATA_STREAM 57

Table 38 Example CATS_REGISTER_IDENTIFIER..... 57

Table 39 Example CATS_NMI_DATA_STREAM 57

Table 40 Example CATS_REGISTER_IDENTIFIER..... 57

Table 41 Example CATS_NMI_DATA_STREAM 58

Table 42 Example CATS_REGISTER_IDENTIFIER..... 58

Table 43 Example CATS_NMI_DATA_STREAM 58

Table 44 Example CATS_NMI_DATA_STREAM 59

Table 45 Example CATS_REGISTER_IDENTIFIER..... 59

Table 46 Example CATS_NMI_DATA_STREAM 59

Table 47 Example CATS_REGISTER_IDENTIFIER..... 60

Table 48 Example CATS_NMI_DATA_STREAM 60

Table 49 Example CATS_REGISTER_IDENTIFIER..... 60

Table 50 BROWSER FORMATS 61

1. INTRODUCTION

1.1. Purpose and scope

This document details the data requirements for the various data elements comprising the CATS Standing Data stored for each *NMI*, together with relevant examples and definitions.

This document forms part of each of the Retail Electricity Market Procedures and will be amended when another Retail Electricity Market Procedure requires amendment. The consultation process applicable to the relevant Retail Electricity Market Procedure will also apply to the necessary amendments to this document.

1.2. Definitions and interpretation

The Retail Electricity Market Procedures – Glossary and Framework:

- a) is incorporated into and forms part of this document; and
- b) should be read with this document.

1.3. Related documents

Title	Location
Retail Electricity Market Procedures – Glossary and Framework	https://www.aemo.com.au/Electricity/National-Electricity-Market-NEM/Retail-and-metering
CATS Procedures	http://www.aemo.com.au/Electricity/National-Electricity-Market-NEM/Retail-and-metering/Market-Settlement-and-Transfer-Solutions
WIGS Procedures	http://www.aemo.com.au/Electricity/National-Electricity-Market-NEM/Retail-and-metering/Market-Settlement-and-Transfer-Solutions
MDM Procedures	http://www.aemo.com.au/Electricity/National-Electricity-Market-NEM/Retail-and-metering/Market-Settlement-and-Transfer-Solutions
MSATS CATS history Model	http://www.aemo.com.au/Electricity/National-Electricity-Market-NEM/Retail-and-metering/Market-Settlement-and-Transfer-Solutions
MSATS guides	http://www.aemo.com.au/Electricity/National-Electricity-Market-NEM/Retail-and-metering/Market-Settlement-and-Transfer-Solutions

2. BACKGROUND

The five MSATS master tables contain the standing data stored for each *NMI*. They are the following:

Table 1 MSATS Master Tables

Table	Summary of Contents
CATS_NMI_DATA	Address, TNI Code, DLF Code, aggregate flag, embedded network names, Jurisdiction, NMI status code, etc.
CATS_NMI_PARTICIPANT_RELATIONS	Roles and associated Participants. Separate records are maintained for each Role/Participant relationship.
CATS_NMI_DATA_STREAM	Suffix, ADL Code, Profile Name, Datastream type and datastream status of each MDM Datastream.
CATS_METER_REGISTER	Meter Serial ID, meter type, meter manufacturer, test results, etc.
CATS_REGISTER_IDENTIFIER	Meter Serial ID, Network Tariff Code, unit of measure etc.

For a *NMI* to be capable of being used in MSATS, it must have the following minimum set of data:

- At least one record on the CATS_NMI_DATA table; and
- At least eight records on the CATS_NMI_PARTICIPANT_RELATIONS table, one for each of the mandatory roles (ROLR, LNSP, LR, RP, FRMP, MDP, MPC and MPB).

It will also normally have:

- At least one record on each of the CATS_METER_REGISTER and CATS_REGISTER_IDENTIFIER (there should be at least one record for each *meter* and register associated with the *NMI*) tables.

NMIs may or may not have:

- Records on the CATS_NMI_DATA_STREAM table. If *metering data* is to be submitted to MDM there must be at least one valid record on this table.

Every time a change is made to any of the data in any of these tables, the old records are made inactive and new records are created, thus ensuring that there is a complete history of all changes.

3. CONVENTIONS USED WITHIN THIS DOCUMENT

The format of the data fields in the 'Browser Format Column' column of Tables is as defined in Section 16.

The following information defines the coded entries in columns used in Tables 3, 6, 9, 12, 15, 18 and 21.

3.1. Column Headed: Standing Data Required

The column indicates the requirement to provide this data to MSATS.

Table 2 Explanation of Standing Data Requirements

Requirement	Description
MANDATORY	Transfer, Validation or processing cannot proceed without this data.
REQUIRED	This data must be provided if this information is available.
OPTIONAL	This data is not required, but will be accepted if delivered.
Address Option 1	AEMO's preferred address option. If the applicable fields labelled "Address Option 1" cannot be provided, "Address Option 2" is MANDATORY.
Address Option 2	AEMO's non-preferred address option. If Address Option 1 is provided, these fields are not to be supplied.

3.2. NMIs Affected

Data must be provided for every *NMI* in MSATS. The *NMIs* that must be registered in MSATS are:

- All *connection points* where a *transmission network* connects to another *transmission network*.

- All *connection points* where a *transmission network* connects to a *distribution network*, i.e. *bulk supply connection points*.
- All *transmission network connection points* where *energy* is directly purchased from the *spot market* by a *Market Customer*, i.e. *wholesale connection points*.
- All *connection points* on a *distribution network* that connect that *distribution network* to an adjacent *distribution network* (other than an *embedded network*), i.e. *cross boundary connection points*.
- Sample meters as required by Metrology Procedures Part A to calculate CLP for participating jurisdictions.
- All *connection points* associated with a *non-registered embedded generator*, i.e. a *generating unit* that is not classified by a *Market Generator*, but is eligible to be classified by a *Small Generation Aggregator* as a *market generating unit*.
- All *type 7 loads*.
- All *non-contestable unmetered loads*.
- All *connection points* associated with a *generating unit* classified by a *Market Generator*.
- All *distribution network connection points* where *energy* is directly purchased from the *spot market* by a *Market Customer*.
- All *distribution network connection points* where there is a *market load*.
- All *child connection points*.

4. CATS_METER_REGISTER

4.1. Field Definitions

The CATS_Meter_Register table is a NMI master table containing data that is stored at the Meter Register level. Information stored at this level includes the NSRD. It is updated whenever a Change Request containing inbound Meter Register data is completed.

Note: References to 'LNSP' include the ENM for *child connection points*.

Table 3 CATS_METER_REGISTER – Field Definitions

Data Element Name	Description	Standing Data Required	Party to Provide
AdditionalSiteInformation	Free text, descriptive of the Site, describing Site access and the relationship between the <i>metering point</i> and the <i>connection point</i> .	OPTIONAL	MPB
AssetManagementPlan	Asset management plan If a Site plan is used, free text description of plan. If a sample plan is used, the name of the AEMO approved plan.	OPTIONAL	MPB
CalibrationTables	Calibration tables – details of any calibration factors programmed into the <i>meter</i> .	OPTIONAL	MPB
CommunicationsEquipmentType	Used to store baud rate for installed communication equipment in a code, calculated by dividing the baud rate by 100, of the installed communication equipment. For example, 48 = 4800 baud.	OPTIONAL	MPB
CommunicationsProtocol	Used to provide details of access through switch units (if installed). Data to include Switch Unit, Dial Pkg, Port#, userid, password.	OPTIONAL	MPB
DataConversion	Actual Pulse Multipliers	OPTIONAL	MPB
DataValidations	Free text description of required data validations.	OPTIONAL	MPB
EstimationInstructions	Estimation instructions. Free text field	OPTIONAL	MPB
LastTestDate	The date on which the <i>metering installation</i> was last tested or inspected by the Metering Provider "B". This date will be used if clause 7.9.4(a) of the NER needs to be applied.	REQUIRED	MPB
MeasurementType	Code based on the <i>NMI</i> suffix codes, indicating the type of measurements available from the <i>meter</i> . For example, EBQK = bidirectional <i>energy</i> plus reactive Interval Meter.	OPTIONAL NOT USED for types 6 & 7 Transfers.	MPB

STANDING DATA FOR MSATS



Data Element Name	Description	Standing Data Required	Party to Provide
Constant	The <i>meter</i> K_E (intrinsic constraint of meter in Wh/pulse).	OPTIONAL	MPB
Hazard	Free text or code identifying hazards associated with reading the <i>meter</i> .	OPTIONAL	MPB
InstallationTypeCode	The <i>InstallationTypeCode</i> may identify attributes of a physical <i>metering installation</i> , <i>metering data</i> collection methods or <i>metering data</i> calculation methods. This value must correspond to a valid Meter Installation Type Code as referenced in MSATS Procedures: CATS Procedures.	MANDATORY	MPB
Location	Free text descriptive material identifying the relationship between the location of the <i>metering point</i> and the <i>connection point</i> .	REQUIRED	MPB
Manufacturer	Free text field to identify the manufacturer of the installed <i>meter</i> .	OPTIONAL	MPB
Model	Free text field to identify the <i>meter</i> manufacturer's designation for the <i>meter</i> model.	OPTIONAL	MPB
Point	Identifies the <i>meter</i> uniquely for the <i>NMI</i> . In the format 0n, where n is the <i>meter</i> number per the protocol described in the <i>NMI</i> Procedure. The allowed values are 01 to 09, 0A to 0H, 0J to 0N, 0P to 0Z. This will allow an audit trail when one <i>meter</i> is removed and a new <i>meter</i> is given the same <i>MeterPoint</i> value.	OPTIONAL	MPB
Program	Free text field providing a description of the program used to initialise the installed <i>meter</i> .	OPTIONAL	MPB

STANDING DATA FOR MSATS



Data Element Name	Description	Standing Data Required	Party to Provide
ReadTypeCode	<p>Code to denote the method and frequency of Meter Reading.</p> <p>First Character = Remote (R) or Manual (M);</p> <p>Second Character = Mode</p> <p>T = telephone</p> <p>W = wireless</p> <p>P = powerline</p> <p>I = infra-red</p> <p>G = galvanic</p> <p>V = visual</p> <p>Third Character = Frequency of Scheduled Meter Readings</p> <p>1 = Twelve times per year</p> <p>2 = Six times per year</p> <p>3 = Four times per year</p> <p>D = Daily or weekly</p> <p>Fourth Character =</p> <ul style="list-style-type: none"> o A – 5 minute o B – 15 minute o C – 30 minute o D – Cannot convert to 5-minute (i.e. due to metering installation de-energised) o M - Manually Read Accumulation Meter <p>For example, MV3M = Manual, Visual, Quarterly, Manually Read Accumulation Meter; RWDC = Remote, Wireless, Daily, 30 minutes interval, RWD = Remote, Wireless, Daily (applicable for Vic AMI <i>metering installations</i> where InstallationTypeCode = 'MRIM' and JurisdictionCode = 'Victoria').</p>	REQUIRED	MPB
Route	The route identifier the <i>meter</i> is currently being read in.	OPTIONAL	MPB

Data Element Name	Description	Standing Data Required	Party to Provide
SerialNumber	The Meter Serial ID uniquely identifies a <i>meter</i> for a given <i>NMI</i> . Maximum 12 Characters (alpha numeric). Unique for <i>NMI</i> . Use dummy for UMCP (Type 7), logical (meters) and <i>non-contestable unmetered loads</i> . Except for UMCP, logical, and <i>non-contestable unmetered loads</i> , SerialNumber should be as displayed on the physical device (also known as property number). SerialNumber to be property number if exists, otherwise the <i>meter</i> manufacturer's serial number, otherwise dummy number.	MANDATORY	MPB
Status	A code to denote the status of the <i>meter</i> . This value must correspond to a valid Meter Register Status as specified in the MSATS Procedures: CATS Procedures.	MANDATORY	MPB
Use	A code identifying how the <i>meter</i> is used.	OPTIONAL	MPB
NextScheduledReadDate	Indicates the Scheduled Next Read Date for the <i>meter</i> if a manual Meter Reading is required.	OPTIONAL	MPB initially, then MDP for updates
NextTestDate	Next date on which the <i>meter</i> should be tested.	OPTIONAL	MPB
NMI	<i>NMI</i> . This number is unique for each <i>connection point</i> within the <i>NEM</i> .	MANDATORY	LNSP
Password	Read & time set passwords separated by a space.	OPTIONAL	MPB
RemotePhoneNumber	The public telephone number to contact a remote Site for <i>metering data</i> . Includes STD prefix and no spaces.	OPTIONAL	MPB
TestCalibrationProgram	Test & calibration program.	OPTIONAL	MPB
TestPerformedBy	Identifying the Metering Provider "B" and the technician responsible for conducting the last test. The technician is to be identified by a number unique to the Metering Provider "B".	OPTIONAL	MPB
TestResultAccuracy	The accuracy figure from the test performed on the date indicated in the LastTestDate field.	OPTIONAL	MPB
TestResultNotes	A statement of compliance indicating the standard of the test regime applied at the time of the last test.	OPTIONAL	MPB
TransformerLocation	A free text field to identify the existence of instrument transformers and their location relative to the market connection point.	OPTIONAL	MPB

Data Element Name	Description	Standing Data Required	Party to Provide
TransformerRatio	A statement of the available and applied <i>transformer</i> ratios.	OPTIONAL	MPB
TransformerType	An explanation of the type of <i>transformation</i> used.	OPTIONAL	MPB
UserAccessRights	Details of any End User access to the <i>metering installation</i> ; examples include pulse outputs, interface to consumer load management system, or consumer directly accessing data in <i>meter</i> by special agreement.	OPTIONAL	MPB
FromDate	Start date of the record. This indicates the date on which the parameters of this particular record apply from. The data applies from the beginning of this date (the start of the day, i.e. 00:00).	MANDATORY	Participant sending transaction
ToDate	End date of the record. This indicates the date on which the parameters of this particular record end. The data applies until the end of this date (the end of the day, i.e. 23:59). A default date of 9999-12-31 is recorded if EndDate is not provided.	MANDATORY (Defaults to high date unless supplied)	System generated unless supplied.
RowStatus	Indicates whether the record is active or inactive. Whenever a new record is created, it will be A (Active). A change to the data will make this record redundant and its MaintActFlg is changed to I (Inactive).	MANDATORY	System generated
MaintenanceDate	Date and time the record was updated. A default date of 9999-12-31 is used when the record is created initially. If the record is subsequently updated, its MaintUpdtDt is changed to the date and time the record was updated.	MANDATORY	System generated
CreationDate	Date and time the record was created.	MANDATORY	System generated

4.2. Cross Reference of Browser and aseXML Data Elements

The table below lists the names that are used in the MSATS browser. The table also provides the aseXML data element names and the respective formats used in each context.

In some cases, such as date fields, the format of the field is shown differently in the Browser to that used in the related aseXML transactions. Also, aseXML uses full words throughout, rather than the coded values used in the Browser.

Section 16 provides data type conventions of the Browser formats shown in this section.

Table 4 CATS_Meter_Register – Browser Cross Reference

Browser Field Name	aseXML Data Element Name	aseXML Path	Browser Format	aseXML Data Type
Additional Site Information	AdditionalSiteInformation	ElectricityMeter/AdditionalSiteInformation	VARCHAR2(100)	xsd:string maxLen = 100
Asset Management Plan	AssetManagementPlan	ElectricityMeter/AssetManagementPlan	VARCHAR2(50)	xsd:string maxLen = 50
Calibration Tables	CalibrationTables	ElectricityMeter/CalibrationTables	VARCHAR2(50)	xsd:string maxLen = 50
Communication Equipment Type	Communications EquipmentType	ElectricityMeter/CommunicationsEquipmentType	VARCHAR2(4)	xsd:string maxLen = 4
Communication Protocol	CommunicationsProtocol	ElectricityMeter/CommunicationsProtocol	VARCHAR2(50)	xsd:string maxLen = 50
Data Conversion	DataConversion	ElectricityMeter/DataConversion	VARCHAR2(50)	xsd:string maxLen = 50
Data Validations	DataValidations	ElectricityMeter/DataValidations	VARCHAR2(50)	xsd:string maxLen = 50
Estimation Instruction	EstimationInstructions	ElectricityMeter/EstimationInstructions	VARCHAR2(50)	xsd:string maxLen = 50
Last Test Date	LastTestDate	ElectricityMeter/LastTestDate	dd-mmm-yyyy	xsd:date
Measurement Type	MeasurementType	ElectricityMeter/MeasurementType	VARCHAR2(4)	xsd:string maxLen = 4
Meter Constant	Constant	ElectricityMeter/Constant	VARCHAR2(12)	xsd:string maxLen = 12
Meter Hazard	Hazard	ElectricityMeter/Hazard	VARCHAR2(12)	xsd:string maxLen = 12
Meter Installation Type Code	InstallationTypeCode	ElectricityMeter/InstallationType Code	VARCHAR2(8)	xsd:string maxLen = 8

STANDING DATA FOR MSATS



Browser Field Name	aseXML Data Element Name	aseXML Path	Browser Format	aseXML Data Type
Meter Location	Location	ElectricityMeter/Location	VARCHAR2(50) See AddSiteInfo (above)	xsd:string maxLen = 50
Meter Manufacturer	Manufacturer	ElectricityMeter/Manufacturer	VARCHAR2(15)	xsd:string maxLen = 15
Meter Model	Model	ElectricityMeter/Model	VARCHAR2(12)	xsd:string maxLen = 12
Meter Point	Point	ElectricityMeter/Point	VARCHAR(2)	xsd:string maxLen = 2
Meter Program	Program	ElectricityMeter/Program	VARCHAR2(30)	xsd:string maxLen = 30
Meter Read Type	ReadTypeCode	ElectricityMeter/ReadTypeCode	VARCHAR(4)	xsd:string maxLen = 4
Meter Route	Route	ElectricityMeter/Route	VARCHAR2(12)	xsd:string maxLen = 12
Meter Serial ID Meter ID (Different on two screens)	SerialNumber	ElectricityMeter/SerialNumber	VARCHAR2(12)	xsd:string maxLen = 12
Status Code	Status	ElectricityMeter/Status	CHAR(1)	xsd:string with enumeration
Meter Use	Use	ElectricityMeter/Use	VARCHAR2(10)	xsd:string maxLen = 10
Next Scheduled Read Date	NextScheduled ReadDate	ElectricityMeter/NextScheduled ReadDate	dd-mmm-yyyy	xsd:date
Next Test Date	NextTestDate	ElectricityMeter/NextTestDate	dd-mmm-yyyy	xsd:date
NMI	NMI	NMI	CHAR(10)	xsd:string maxLen = 10

STANDING DATA FOR MSATS



Browser Field Name	aseXML Data Element Name	aseXML Path	Browser Format	aseXML Data Type
Passwords	Password	ElectricityMeter/Password	VARCHAR2(20)	xsd:string maxLen = 20
Remote Phone Number	RemotePhoneNumber	ElectricityMeter/RemotePhone Number	VARCHAR2(12)	xsd:string maxLen = 12
Test & Calibration Program	TestCalibrationProgram	ElectricityMeter/TestCalibration Program	VARCHAR2(50)	xsd:string maxLen = 50
Test Performed By	TestPerformedBy	ElectricityMeter/TestPerformedBy	VARCHAR2(20)	xsd:string maxLen = 20
Test Result Accuracy	TestResultAccuracy	ElectricityMeter/TestResultAccuracy	NUMBER(8,5)	xsd:decimal totaldig = 8 fracdig = 5
Test Result Notes	TestResultNotes	ElectricityMeter/TestResultNotes	VARCHAR2(50)	xsd:string maxLen = 50
Transformer Location	TransformerLocation	ElectricityMeter/Transformer Location	VARCHAR2(30)	xsd:string maxLen = 30
Transformer Ratio	TransformerRatio	ElectricityMeter/TransformerRatio	VARCHAR2(20)	xsd:string maxLen = 20
Transformer Type	TransformerType	ElectricityMeter/TransformerType	VARCHAR2(20)	xsd:string maxLen = 20
User Access Rights	UserAccessRights	ElectricityMeter/UserAccessRights	VARCHAR2(50)	xsd:string maxLen = 50
Start Date	FromDate	FromDate	dd-mmm-yyyy	xsd:dateTime
End Date	ToDate	ToDate	dd-mmm-yyyy	xsd:dateTime
Updated On	MaintenanceDate	MaintenanceDate	dd-mmm-yyyy (summary screen) dd-mmm-yyyy hh:mm:ss (detail screen)	xsd:dateTime

Browser Field Name	aseXML Data Element Name	aseXML Path	Browser Format	aseXML Data Type
Created On	CreationDate	CreationDate	dd-mmm-yyyy (summary screen) dd-mmm-yyyy hh:mm:ss (detail screen)	xsd:dateTime
Activity Status	RowStatus	RowStatus	CHAR(1)	xsd:string with enumeration

4.3. Field value examples

This section provides examples of typical sets of data element values associated with different types of *connection points*.

The data shown in each example is as shown in the Browser. This reverses the sequence of the day-month-year communicated via aseXML transactions.

Table 5 MSATS_Meter_Register – Example

Data Element Name (as it appears in XML documents)	Browser Field Name(as it appears in MSATS Browser)	Basic Example	Interval Example	Data Element Name
AdditionalSiteInformation	Additional Site Information	MTR ON SITE AT 17B	Red Rooster	AdditionalSiteInformation
AssetManagementPlan	Asset Management Plan	CITIPower METER MANAGEMENT PLAN	PER CE DOC: TYPES 1-4 ASSET MANAGEMENT & TEST PLAN	AssetManagementPlan
CalibrationTables	Calibration Tables	Q		CalibrationTables
CommunicationsEquipment Type	Communication Equipment Type	FACE	96	CommunicationsEquipmentType
CommunicationsProtocol	Communication Protocol	NA	EMAIL MINI GATEWAY S/N SU121 MV90 2 TBD TBD	CommunicationsProtocol
DataConversion	Data Conversion	.0005	.0005	DataConversion

STANDING DATA FOR MSATS



Data Element Name (as it appears in XML documents)	Browser Field Name(as it appears in MSATS Browser)	Basic Example	Interval Example	Data Element Name
DataValidations	Data Validations	As per Metrology Procedure Part B	As per Metrology Procedure Part B	DataValidations
EstimationInstructions	Estimation Instruction	As per Metrology Procedure Part B (TYPES -61, 62, 65)	As per Metrology Procedure Part B (TYPES -14)	EstimationInstructions
LastTestDate	Last Test Date	07-05-2004	07-03-2004	LastTestDate
MeasurementType	Measurement Type	EQ	EQ	MeasurementType
Constant	Meter Constant	40	.5	Constant
Hazard	Meter Hazard		Asbestos	Hazard
InstallationTypeCode	Meter Installation Type Code	BASIC	COMMS4	InstallationTypeCode
Location	Meter Location	ON SUB POLE	BEHIND DOOR	Location
Manufacturer	Meter Manufacturer	EMAIL	EDMI	Manufacturer
Model	Meter Model	Q3	Q4	Model
Point	Meter Point	01	01	Point
Program	Meter Program	30 - NP 3.2 CT FACE PLATE READ	10- AE CT kVAR 9600	Program
ReadTypeCode	Meter Read Type	MV3M	RTDA	ReadTypeCode
Route	Meter Route	11618	1305	Route
SerialNumber	Meter Serial ID, Meter ID (Different on two screens)	525811	201000299	SerialNumber
Status	Status Code	C	C	Status
Use	Meter Use	REVENUE	REVENUE	Use
NextScheduledReadDate	Next Scheduled Read Date	04-10-2006		NextScheduledReadDate
NextTestDate	Next Test Date	17-05-2004	10-05-2004	NextTestDate

STANDING DATA FOR MSATS



Data Element Name (as it appears in XML documents)	Browser Field Name(as it appears in MSATS Browser)	Basic Example	Interval Example	Data Element Name
NMI	NMI	1122334455	1122334455	NMI
Password	Passwords	12345	12345	Password
RemotePhoneNumber	Remote Phone Number	FACE READ	0555 825 987	RemotePhoneNumber
TestCalibrationProgram	Test & Calibration Program	AS PER AS/NZ 1284	AS PER AS/NZ 1284	TestCalibrationProgram
TestPerformedBy	Test Performed By	Ron Sargeant	SMU	TestPerformedBy
TestResultAccuracy	Test Result Accuracy	-0.20000	-0.11000	TestResultAccuracy
TestResultNotes	Test Result Notes	CHECK AND RESEAL METER	METER TEST CORRECT	TestResultNotes
TransformerLocation	Transformer Location		REAR OFBUILDING	TransformerLocation
TransformerRatio	Transformer Ratio		1500/5	TransformerRatio
TransformerType	Transformer Type		24 WIRE WOUND	TransformerType
UserAccessRights	User Access Rights	AS PER AS/NZ 1284	MDP ONLY ACCESS	UserAccessRights
FromDate	Start Date	14-03-1990	16-03-2002	FromDate
ToDate	End Date	31-12-9999	18-07-2006	ToDate
MaintenanceDate	Updated On	31-12-999 00:00:00	31-12-999 00:00:00	MaintenanceDate
CreationDate	Created On	19-03-1990 00:01:00	18-03-2002 00:01:00	CreationDate

5. CATS_DLF_CODES

5.1. Field Definitions

The CATS_DLF_Codes table contains a list of DLF Codes and their relevant values. The StartDate and DLFCODE fields will need to be provided for *settlements* calculations.

Note: References to 'LNSP' include the ENM for child *connection points*.

Table 6 CATS_DLF_CODES – Field Definitions

Data Element Name	Description	Standing Data Required	Party to Provide
DistributionLossFactorCode	A four character alpha-numeric code used to identify DLF values. All <i>NMIs</i> must be assigned a DLF Code. Refer to AEMO Distribution Loss Factor documents for each financial year..	MANDATORY	AEMO
DistributionLossFactorDescription	Description of the DLF Code and value.	MANDATORY	AEMO
DistributionLossFactor Value	Numeric value up to 5 decimal places, reflecting the value of the DLF Code.	MANDATORY	AEMO
JurisdictionCode	Jurisdiction code to which the <i>NMI</i> belongs. This value must correspond to Jurisdiction Code values as specified in the MSATS Procedures: CATS Procedures.	MANDATORY	AEMO
RowStatus	Indicates whether the DLF Code is active or inactive. Whenever a new record is created, it will be A (Active). A change to the data will make this record redundant and its MaintActFlg is changed to I (Inactive).	MANDATORY	System generated
FromDate	Start date of the record. This indicates the date on which the parameters of this particular record apply from. The data applies from the beginning of this date (the start of the day, i.e. 00:00).	MANDATORY	AEMO
ToDate	End date of the record. This indicates the date on which the parameters of this particular record end. The data applies until the end of this date (the end of the day, i.e. 23:59). A default date of 9999-12-31 is recorded if EndDate is not provided.	MANDATORY	System generated
MaintenanceDate	Date and time the record was updated. A default date of 9999-12-31 is used when the record is created initially. If the record is subsequently updated, its MaintUpdtDt is changed to the date and time the record was updated.	MANDATORY	System generated
CreationDate	Date and time the record was created.	MANDATORY	System generated

5.2. Cross Reference of Browser and aseXML Data Elements

The table below lists the names that are used in the MSATS browser. The table also provides the aseXML data element names and the respective formats used in each context.

In some cases, such as date fields, the format of the field is shown differently in the Browser to that used in the related aseXML transactions. Also, aseXML uses full words throughout, rather than the coded values used in the Browser.

Section 16 provides data type conventions of the Browser formats shown in this section.

Table 7 CATS_DLF_Codes - Browser Cross Reference

Browser Field Name	aseXML Data Element Name	aseXML Path	Browser Format	aseXML Data Type
DLF Code	DistributionLossFactorCode	DistributionLossFactorCode	VARCHAR2(4)	xsd:string maxLen = 4
Description	DistributionLossFactorDescription	DistributionLossFactorDescription	VARCHAR2(50)	xsd:string maxLen = 50
DLF Value	DistributionLossFactorValue	DistributionLossFactorValue	NUMBER(6,5)	xsd:decimal minIncl = 0 maxIncl = 2 totdig = 6 fracdig = 5
Jurisdiction	JurisdictionCode	ElectricityStandingData/MasterData/JurisdictionCode	VARCHAR2(3)	xsd:string maxLen = 3
Activity Status	RowStatus	RowStatus	CHAR(1)	xsd:string with enumeration
Start Date	FromDate	FromDate	dd-mmm-yyyy	xsd:dateTime
End Date	ToDate	ToDate	dd-mmm-yyyy	xsd:dateTime
Updated On	MaintenanceDate	MaintenanceDate	dd-mmm-yyyy (summary screen) dd-mmm-yyyy hh:mm:ss (detail screen)	xsd:dateTime

Browser Field Name	aseXML Data Element Name	aseXML Path	Browser Format	aseXML Data Type
	CreationDate	CreationDate	dd-mmm-yyyy (summary screen) dd-mmm-yyyy hh:mm:ss (detail screen)	xsd:dateTime

5.3 Field value examples

This section provides examples of typical sets of data element values associated with different types of *connection points*.

The data shown in each example is as shown in the Browser. This reverses the sequence of the day-month-year communicated via aseXML transactions.

Table 8 CATS_DLF_Codes - Example

Data Element Name	Browser Field Name	Basic & Interval Example
DistributionLossFactorCode	DLF Code	NHV1
DistributionLossFactorDescription	Description	UMPLP - High Voltage
DistributionLossFactorValue	[The actual DLF value]	1.1111
JurisdictionCode	Jurisdiction Code	SA
RowStatus	Activity Status	A
FromDate	Start Date	01-07-1999
ToDate	End Date	30-06-2000
MaintenanceDate	Updated On	31-05-2000 00:30:27
CreationDate		01-06-1999 00:23:32

6. CATS_EMB_NET_ID_CODES

6.1. Field Definitions

The CATS_EMB_NET_ID_CODES table contains embedded network identifier codes, which are used to identify which *embedded network* a *NMI* belongs to, either as a Parent NMI or a Child NMI.

Note: References to 'LNSP' include the ENM for *child connection points*.

Table 9 CATS_EMB_NET_ID_CODES – Field Definitions

Data Element Name	Description	Standing Data Required	Party to Provide
EmbeddedNetworkIdentifier	Embedded Network Code. Refer to Allocation of Embedded Network Codes for further details.	MANDATORY	AEMO
EmbeddedNetworkDescription	Description of embedded network identifier.	MANDATORY	AEMO
SuburbOrPlaceOrLocality	Locality to which the embedded network identifier belongs.	MANDATORY	AEMO
PostCode	Postcode for the locality to which the embedded network identifier belongs.	MANDATORY	AEMO
StateOrTerritory	State or Territory abbreviation in accordance with AS 4590.	MANDATORY	AEMO
RowStatus	Indicates whether the code is active or inactive. Whenever a new record is created, it will be A (Active). A change to the data will make this record redundant and its MaintActFlg is changed to I (Inactive).	MANDATORY	System generated
FromDate	Start date of the record. This indicates the date on which the parameters of this particular record apply from. The data applies from the beginning of this date (the start of the day, i.e. 00:00).	MANDATORY	AEMO
ToDate	End date of the record. This indicates the date on which the parameters of this particular record end. The data applies until the end of this date (the end of the day, i.e. 23:59). A default date of 9999-12-31 is recorded if EndDate is not provided.	MANDATORY	System generated
MaintenanceDate	Date and time the record was updated. A default date of 9999-12-31 is used when the record is created initially. If the record is subsequently updated, its MaintUpdtDt is changed to the date and time the record was updated.	MANDATORY	System generated

STANDING DATA FOR MSATS



Data Element Name	Description	Standing Data Required	Party to Provide
CreationDate	Date and time the record was created.	MANDATORY	System generated

6.2. Cross Reference of Browser and aseXML Data Elements

The table below lists the names that are used in the MSATS browser. The table also provides the aseXML data element names and the respective formats used in each context.

In some cases, such as date fields, the format of the field is shown differently in the Browser to that used in the related aseXML transactions. Also, aseXML uses full words throughout, rather than the coded values used in the Browser.

Section 16 provides data type conventions of the Browser formats shown in this section.

Table 10 CATS_Emb_Net_ID_Codes - Browser Cross Reference

Browser Field Name	aseXML Data Element Name	aseXML Path	Browser Format	aseXML Data Type
Code	EmbeddedNetworkIdentifier	EmbeddedNetworkIdentifier	VARCHAR2(10)	xsd:string maxLen = 10
Description	EmbeddedNetworkDescription	EmbeddedNetworkDescription	VARCHAR2(50)	xsd:string maxLen = 50
Locality/Suburb	SuburbOrPlaceOrLocality	ElectricityStandingData/MasterData/Address/AustralianAddress/ SuburbOrPlaceOrLocality	VARCHAR2(46)	xsd:string maxLen = 46
Postcode	PostCode	ElectricityStandingData/MasterData/Address/AustralianAddress/ PostCode	VARCHAR2(4)	xsd:string pattern: [\p{N}]{4}
State	StateOrTerritory	ElectricityStandingData/MasterData/Address/AustralianAddress/ StateOrTerritory	VARCHAR2(3)	xsd:string with enumerations
Activity Status	RowStatus	RowStatus	CHAR(1)	xsd:string with enumeration
Start Date	FromDate	FromDate	dd-mmm-yyyy	xsd:dateTime
End Date	ToDate	ToDate	dd-mmm-yyyy	xsd:dateTime

Browser Field Name	aseXML Data Element Name	aseXML Path	Browser Format	aseXML Data Type
Updated On	MaintenanceDate	MaintenanceDate	dd-mmm-yyyy (summary screen) dd-mmm-yyyy hh:mm:ss (detail screen)	xsd:dateTime
Created On	CreationDate	CreationDate	dd-mmm-yyyy (summary screen) dd-mmm-yyyy hh:mm:ss (detail screen)	xsd:dateTime

6.3. Field value examples

This section provides examples of typical sets of data element values associated with different types of *connection points*.

The data shown in each example is as shown in the Browser. This reverses the sequence of the day-month-year communicated via aseXML transactions.

Table 11 CATS_Emb_Net_ID_Codes - Example

Data Element Name	Browser Field Name	Basic & Basic Example
EmbeddedNetworkIdentifier	Code	SE01008111
EmbeddedNetworkDescription	Description	Kingston-On-Murray Caravan Park
SuburbOrPlaceOrLocality	Suburb / Locality	Kingston-On-Murray
PostCode	Postcode	5331
StateOrTerritory	State	SA
RowStatus	Activity Status	A
FromDate	Start Date	5/04/2003
ToDate	End Date	31/12/9999
MaintenanceDate	Updated On	31/12/9999
CreationDate	Creation On	1/04/2003 13:23

7. CATS_NMI_DATA

7.1. Field Definitions

The CATS_NMI_DATA table records Master NMI Record data information. It is updated whenever a Change Request containing data in the CATS_INBOUND_NMI_DATA table is completed.

Note: References to 'LNSP' include the ENM for *child connection points*.

Table 12 CATS_NMI_DATA – Field Definitions

Data Element Name	Description	Standing Data Required	Party to Provide
NMI	<i>NMI</i> . All alpha characters are Upper Case	MANDATORY	LNSP
NMI ClassificationCode	Code used to indicate the NMI Classification Code of this <i>NMI</i> . This value must correspond to NMI Classification Code values as specified in the MSATS Procedures: CATS Procedures.	MANDATORY	LNSP
MasterData/ StatusCode	Code used to indicate the status of the <i>NMI</i> . This value must correspond to NMI Status Code values as specified in the MSATS Procedures: CATS Procedures.	MANDATORY	LNSP
TransmissionNode Identifier	This value must correspond to a valid code in the CATS_TNI_Codes table.	MANDATORY	LNSP
TransmissionNode Identifier2	TNI Code assigned, by AEMO, to a distribution network into which energy normally flows through a connection point between adjacent distribution networks that has a single NMI. This value must correspond to a valid code in the CATS_TNI_Codes table.	REQUIRED	AEMO
SharedIsolationPointFlag	A flag (Yes, No, Isolated or Unknown) to indicate the Shared Fuse Arrangement for the <i>metering installation</i> . Valid values are Y, N, I or U. This value must correspond to a valid shared isolation point flag value in the Valid Shared Isolation Point Flag Values reference table listed in section 11.	MANDATORY	LNSP
JurisdictionCode	Jurisdiction code to which the <i>NMI</i> belongs. This code defines the jurisdictional rules which apply to the transfer of this <i>NMI</i> . This value must correspond to Jurisdiction Code values as specified in the MSATS Procedures: CATS Procedures.	MANDATORY	LNSP

Data Element Name	Description	Standing Data Required	Party to Provide
DistributionLossFactorCode	Distribution Loss Factor Code. Must be a valid code in the CATS_DLF_Codes table.	MANDATORY	LNSP
ChildEmbeddedNetworkIdentifier	The embedded network identifier code is used to identify which embedded network this given <i>NMI</i> is the 'child of'. (If on a <i>NMI</i> record this field is not populated, it is assumed the <i>NMI</i> is not the child of any other <i>NMI</i> .) Must be a valid code within the CATS_Emb_Net_ID_Codes table. This field cannot be used unless the Parent <i>NMI</i> has been created and assigned an embedded network identifier code. Refer section 30.4.a of the CATS Procedure.	REQUIRED	LNSP
ParentEmbeddedNetworkIdentifier	The embedded network identifier code is used to identify which <i>embedded network</i> this given <i>NMI</i> is the 'parent of'. (If on a <i>NMI</i> record this field is not populated, it is assumed the <i>NMI</i> is not the parent of any other <i>NMI</i> .) Must be a valid code within the CATS_Emb_Net_ID_Codes table.	REQUIRED	LNSP
BuildingOrPropertyName	A free text description of the full name used to identify the physical building or property as part of its location.	Address Option 1	LNSP
LotNumber	The lot reference number allocated to an address prior to street numbering. The word 'LOT' is not required.	Address Option 1	LNSP
FlatOrUnitNumber	Specification of the number of the flat or unit which is a separately identifiable portion within a building/complex.	Address Option 1	LNSP
FlatOrUnitType	Specification of the type of flat or unit which is a separately identifiable portion within a building/complex. This value must correspond to a valid Flat Type Code, reference AS4590.	Address Option 1	LNSP
FloorOrLevelNumber	Floor Number is used to identify the floor or level of a multi-storey building/complex.	Address Option 1	LNSP
FloorOrLevelType	Floor Type is used to identify the floor or level of a multi-storey building/complex. This value must correspond to a valid Floor Type Code in the Floor Type Codes, reference AS4590.	Address Option 1	LNSP
HouseNumber	The numeric reference of a house or property. Specifically the house number.	Address Option 1	LNSP
HouseNumberSuffix	The numeric reference of a house or property. Specifically the single character identifying the house number suffix.	Address Option 1	LNSP

STANDING DATA FOR MSATS



Data Element Name	Description	Standing Data Required	Party to Provide
StreetName	Records the thoroughfare name. See notes at end of table for more information on Structured Addresses	Address Option 1	LNSP
StreetSuffix	Records street suffixes. This value must correspond to a valid Street Suffix Code, reference AS4590.	Address Option 1	LNSP
StreetType	Records the street type abbreviation. This value must correspond to a valid Street Type Code, reference AS4590.	Address Option 1	LNSP
SuburbOrPlaceOrLocality	The full name of the general locality containing the specific address.	MANDATORY	LNSP
LocationDescriptor	A general field to capture various references to address locations alongside another physical location.	Address Option 1	LNSP
PostCode	The descriptor for a postal delivery area, aligned with locality, suburb or place.	MANDATORY	LNSP
StateOrTerritory	Defined State or Territory abbreviation.	MANDATORY	LNSP
DeliveryPointIdentifier	Delivery point identifier - the numeric descriptor for a postal delivery point which is equal to a physical address. The values are in the range 10000000 – 99999999.	REQUIRED	LNSP/ AEMO
AddressLine	To provide the unstructured address (line 1) where a structured address cannot be supplied.	Address Option 2	LNSP
AddressLine	To provide the unstructured address (line 2) where a structured address cannot be supplied.	Address Option 2	LNSP
AddressLine	To provide the unstructured address (line 3) where a structured address cannot be supplied.	Address Option 2	LNSP

STANDING DATA FOR MSATS



Data Element Name	Description	Standing Data Required	Party to Provide
Aggregate	This flag determines whether the energy at this <i>connection point</i> is to be treated as consumer <i>load</i> or as a <i>generating unit</i> (this may include <i>generator</i> auxiliary loads). MSATS will initially set this field to "Y" This value must correspond to a valid Aggregate value in the Aggregate Codes reference table listed in section 11.	OPTIONAL	(Defaults to 'Y', AEMO updates to 'N' as required)
Feeder Class	A code to provide Participants with information to indicate the appropriate service level timeframes for performing work in relation to Service Order Requests..	Required in QLD where relevant OPTIONAL in all other jurisdictions	LNSP
Customer Classification Code	A code that defines the consumer class as defined in the National Energy Retail Regulations, or in overriding Jurisdictional instruments.	MANDATORY	Current FRMP
Customer Classification Threshold Code	A code that defines the consumption threshold as defined in the National Energy Retail Regulations, or in overriding Jurisdictional instruments.	MANDATORY	LNSP
FromDate	Start date of the NMI Data record. This indicates the date on which the parameters of this particular NMI data record apply from. The data applies from the beginning of this date (the start of the day, i.e. 00:00).	MANDATORY	LNSP
ToDate	End date of the record. This indicates the date on which the parameters of this particular record end. The data applies until the end of this date (the end of the day, i.e. 23:59). A default date of 9999-12-31 is recorded if EndDate is not provided.	MANDATORY (Defaults to high date unless supplied)	System generated unless supplied.
RowStatus	Indicates whether the record is active or inactive. Whenever a new record is created, it will be A (Active). A change to the data will make this record redundant and its MaintActFlg is changed to I (Inactive).	MANDATORY	System generated

Data Element Name	Description	Standing Data Required	Party to Provide
MaintenanceDate	Date and time the record was updated. A default date of 9999-12-31 is used when the record is created initially. If the record is subsequently updated, its MaintUpdtDt is changed to the date and time the record was updated.	MANDATORY	System generated
CreationDate	Date and time the record was created.	MANDATORY	System generated

7.2. Cross Reference of Browser and aseXML Data Elements

The table below lists the names that are used in the MSATS browser. The table also provides the aseXML data element names and the respective formats used in each context.

In some cases, such as date fields, the format of the field is shown differently in the Browser to that used in the related aseXML transactions. Also, aseXML uses full words throughout, rather than the coded values used in the Browser.

Section 16 provides data type conventions of the Browser formats shown in this section.

Table 13 CATS_NMI_Data

Browser Field Name	aseXML Data Element Name	aseXML Path	Browser Format	aseXML Data Type
NMI	NMI	NMI	CHAR(10)	xsd:string maxLen = 10
NMI Classification Code	NMClassificationCode	ElectricityStandingData/MasterData/ NMClassificationCode	VARCHAR2(8)	xsd:string maxLen = 8
Status Code	Status	ElectricityStandingData/MasterData/Status	CHAR(1)	xsd:string maxLen = 1
TNI Code	TransmissionNodelfentifier	ElectricityStandingData/MasterData/TransmissionNodelfentifier	VARCHAR2(4)	xsd:string maxLen = 4
TNI Code 2	TransmissionNodelfentifier2	ElectricityStandingData/MasterData/TransmissionNodelfentifier2	VARCHAR2(4)	xsd:string maxLen = 4
Shared Isolation Point	SharedIsolationPointFlag	ElectricityMeter/ SharedIsolationPointFlag	CHAR(1)	xsd:string

STANDING DATA FOR MSATS



Browser Field Name	aseXML Data Element Name	aseXML Path	Browser Format	aseXML Data Type
Flag				maxLen = 1
Jurisdiction Code	JurisdictionCode	JurisdictionCode	VARCHAR2(3)	xsd:string maxLen = 3
DLF Code	DistributionLossFactorCode	ElectricityStandingData/MasterData/DistributionLossFactor Code	VARCHAR2(4)	xsd:string maxLen = 4
Embedded Network ID (Child)	ChildEmbeddedNetworkIdentifier	ElectricityStandingData/MasterData/ChildEmbeddedNetworkIdentifier	VARCHAR2(10)	xsd:string maxLen = 10
Embedded Network (Parent)	ParentEmbeddedNetworkIdentifier	ElectricityStandingData/MasterData/ParentEmbeddedNetworkIdentifier	VARCHAR2(10)	xsd:string maxLen = 10
Building / Property Name	BuildingOrPropertyName	ElectricityStandingData/MasterData/Address/AustralianAddress/StructuredAddress/BuildingOrPropertyName	VARCHAR2(30)	xsd:string maxLen = 30 x 2
Lot Number	LotNumber	ElectricityStandingData/MasterData/Address/AustralianAddress/StructuredAddress/Lot/LotNumber	VARCHAR2(6)	xsd:string pattern: [\p{L}\p{N}\p{P}\s]{1,6}
Flat/Unit Number	FlatOrUnitNumber	ElectricityStandingData/MasterData/Address/AustralianAddress/StructuredAddress/FlatOrUnit/FlatOrUnitNumber	VARCHAR2(7)	xsd:string pattern: [\p{L}\p{N}\p{P}\s]{1,7}
Flat/Unit Type	FlatOrUnitType	ElectricityStandingData/MasterData/Address/AustralianAddress/StructuredAddress/FlatOrUnit/FlatOrUnitType	VARCHAR2(4)	xsd:string with enumerations
Floor/Level Number	FloorOrLevelNumber	ElectricityStandingData/MasterData/Address/AustralianAddress/StructuredAddress/FloorOrLevel/FloorOrLevelNumber	VARCHAR2(5)	xsd:string [\p{L}\p{N}\p{P}\s]{1,5}
Floor/Level Type	FloorOrLevelType	ElectricityStandingData/MasterData/Address/AustralianAddress/StructuredAddress/FloorOrLevel/FloorOrLevelType	VARCHAR2(2)	xsd:string with enumerations
House Number	HouseNumber	ElectricityStandingData/MasterData/Address/AustralianAddress/StructuredAddress/House/HouseNumber	NUMBER(5)	xsd:nonNegativeInteger maxIncl = 99999
House Number Suffix	HouseNumberSuffix	ElectricityStandingData/MasterData/Address/AustralianAddress/	VARCHAR2(1)	xsd:string pattern: [\p{L}\p{N}]{1}

STANDING DATA FOR MSATS



Browser Field Name	aseXML Data Element Name	aseXML Path	Browser Format	aseXML Data Type
		StructuredAddress/House/HouseNumberSuffix		
Street Name	StreetName	ElectricityStandingData/MasterData/Address/AustralianAddress/ StructuredAddress/Street/StreetName	VARCHAR2(30)	xsd:string pattern: [\p{L}\p{N}s\-']{1,30}
Street Name Suffix	StreetSuffix	ElectricityStandingData/MasterData/Address/AustralianAddress/ StructuredAddress/Street/StreetSuffix	VARCHAR2(2)	xsd:string with enumerations
Street Type	StreetType	ElectricityStandingData/MasterData/Address/AustralianAddress/ StructuredAddress/Street/StreetType	VARCHAR2(4)	xsd:string with enumerations
Suburb/Locality	SuburbOrPlaceOrLocality	ElectricityStandingData/MasterData/Address/AustralianAddress/ SuburbOrPlaceOrLocality	VARCHAR2(46)	xsd:string maxLen = 46
Location Descriptor	LocationDescriptor	ElectricityStandingData/MasterData/Address/AustralianAddress/ StructuredAddress/LocationDescriptor	VARCHAR2(30)	xsd:string pattern: [\p{L}\p{N}\p{P}s]{1,30}
Postcode	PostCode	ElectricityStandingData/MasterData/Address/AustralianAddress/ PostCode	VARCHAR2(4)	xsd:string pattern: [\p{N}]{4}
State	StateOrTerritory	ElectricityStandingData/MasterData/Address/AustralianAddress/ StateOrTerritory	VARCHAR2(3)	xsd:string with enumerations
DPID	DeliveryPointIdentifier	ElectricityStandingData/MasterData/Address/AustralianAddress/ StructuredAddress/DeliveryPointIdentifier	NUMBER(8)	xsd:nonNegativeInteger minIncl = 10000000 maxIncl = 99999999
Unstructured Address	AddressLine	ElectricityStandingData/MasterData/Address/AustralianAddress/ UnstructuredAddress/Address/AddressLine	VARCHAR2(80)	xsd:string maxLen = 80 x 3

Browser Field Name	aseXML Data Element Name	aseXML Path	Browser Format	aseXML Data Type
Aggregate Flag	Aggregate	ElectricityStandingData/MasterData/Aggregate	CHAR(1)	xsd:string with enumeration
Start Date	FromDate	FromDate	dd-mmm-yyyy	xsd:dateTime
End Date	ToDate	ToDate	dd-mmm-yyyy	xsd:dateTime
Updated On	MaintenanceDate	MaintenanceDate	dd-mmm-yyyy (summary screen) dd-mmm-yyyy hh:mm:ss (detail screen)	xsd:dateTime
Created On	CreationDate	CreationDate	dd-mmm-yyyy (summary screen) dd-mmm-yyyy hh:mm:ss (detail screen)	xsd:dateTime
Activity Status	RowStatus	RowStatus	CHAR(1)	xsd:string with enumeration
Feeder Class	Feeder Class	ElectricityStandingData/MasterData/FeederClass	VARCHAR2(15)	xsd:string maxLen = 15
Customer Classification Code	CustomerClassificationCode	ElectricityStandingData/MasterData/CustomerClassificationCode	VARCHAR2(20)	xsd:string maxLen = 20
Customer Classification Threshold Code	CustomerThresholdCode	ElectricityStandingData/MasterData/CustomerThresholdCode	VARCHAR2(20)	xsd:string maxLen = 20

7.3. Field value examples

This section provides examples of typical sets of data element values associated with different types of *connection points*.

The data shown in each example is as shown in the Browser. This reverses the sequence of the day-month-year communicated via aseXML transactions.

Table 14 CATS_NMI_Data Field value examples

Data Element Name	Browser Field Name	Basic Example	Interval Example
NMI	NMI	1223344512	1122334455
NMClassificationCode	NMI Classification Code	SMALL	LARGE
MasterData/Status	Status Code	A	G
TransmissionNodeIdentifier	TNI Code	NRGE	SBER
TransmissionNodeIdentifier2	TNI Code 2		SORA
SharedIsolationPointFlag	Shared Isolation Point Flag	N	Y
JurisdictionCode	Jurisdiction Code	NSW	SA
DistributionLossFactorCode	DLF Code	NRGE	NLV2
ChildEmbeddedNetworkIdentifier	Embedded Network ID (Child)	NS01008111	SE01008111
ParentEmbeddedNetworkIdentifier	Embedded Network (Parent)	NS01008111	SE01008111
BuildingOrPropertyName	Building / Property Name	BP	SHELL
LotNumber	Lot Number	22	23
FlatOrUnitNumber	Flat/Unit Number	1	2
FlatOrUnitType	Flat/Unit Type	U	U
FloorOrLevelNumber	Flat/Unit Number	1	1
FloorOrLevelType	Floor/Level Type	FL	FL
HouseNumber	House Number	6	10
HouseNumberSuffix	House Number Suffix	A	B
StreetName	Street Name	BORIS	DORIS
StreetSuffix	Street Name Suffix	N	W
StreetType	Street Type	DR	ST

STANDING DATA FOR MSATS



Data Element Name	Browser Field Name	Basic Example	Interval Example
SuburbOrPlaceOrLocality	Suburb/Locality	ORANGE	LOXTON
LocationDescriptor	Location Descriptor	CNR FRED ST	SHELL SERVICE STATION
PostCode	Postcode	2211	5333
StateOrTerritory	State	NSW	SA
DeliveryPointIdentifier	DPID	01234567	12345678
AddressLine	Unstructured Address 1	Text	Text
AddressLine	Unstructured Address 2	Text	Text
AddressLine	Unstructured Address 3	Text	Text
Aggregate	Aggregate Flag	Y	Y
FromDate	Start Date	01-06-2004	01-06-2001
ToDate	End Date	31-12-9999	01-01-2003
MaintenanceDate	Updated On	31-12-9999 00:00:00	05-01-2003 00:01:00
CreationDate	Created On	04-01-2004 09:31:00	01-06-2001 00:01:00
RowStatus	Activity Status	A	A
FeederClass	Feeder Class	ERGUD	ERGUD
Customer ClassificationCode	Customer Classification	RESIDENTIAL	BUSINESS
CustomerThresholdCode	Customer Threshold	LOW	HIGH

8. CATS_NMI_DATA_STREAM

8.1. Field Definitions

The CATS_NMI_Data_Stream table is a NMI master table containing data that is stored at the *NMI* Datastream level. Information stored at this level includes suffixes, profile name, average daily load etc. It is updated whenever a Change Request containing inbound Datastream data is completed.

Note: Data is only required for this table if the *NMI* is active in the NEM or is used for profile peel-off in accordance with the Metrology Procedure.

Note: References to 'LNSP' include the ENM for *child connection points*.

Table 15 CATS_NMI_DATA_STREAM – Field Definitions

Data Element Name	Description	Standing Data Required	Party to Provide
NMI	<i>NMI</i>	MANDATORY	MDP LNSP
ElectricityDataStream/Suffix	The Metering Datastream identifier (for MDM). Identifies the ElectricityDataStream Suffix as delivered to AEMO for NEM Settlement calculations, profile peeloff, UFE analysis and Vic TUOS sites. The value must be a valid as per Datastream suffix details specified in the MSATS Procedures: National Metering Identifier procedure. The value must match the MDMContributorySuffix value provided in an MDFF File.	MANDATORY	MDP
ElectricityDataStream/Status	Code used to indicate the status of the suffix. This value must correspond to a valid Datastream Status Code as specified in the MSATS Procedures: CATS procedures.	MANDATORY	MDP
AveragedDailyLoad	The <i>energy</i> delivered or generation delivered via a datastream over an extended period normalised to a "per day" basis (kWh).	MANDATORY	MDP
DataStreamType	Indicates the primary function of the ElectricityDataStream Suffix. i.e. inclusion within NEM Settlement calculations, UFE analysis, profile peeloff or Vic TUOS. This value must correspond to a valid DataStreamType in the Data Stream Type Codes reference table listed in section 11.	MANDATORY	MDP
ProfileName	The Profile Name is a code that identifies the name of the algorithmically derived shape that is used to allocate a Datastream's consumption to TIs. This value must correspond to a valid code in the PROFILE table. For all Interval Meters and sample <i>meters</i> , this must be set to 'NOPROF'. For Accumulation Meters, refer to the MDM Profile for valid profile names. <ul style="list-style-type: none"> In Victoria and the ACT, ProfileName must be NSLP. In NSW, QLD and SA, ProfileName must be NSLP or the relevant controlled load profile. This value must correspond to a valid ProfileName value in the Profile Codes reference table listed in section 11.	MANDATORY	MDP
FromDate	Start date of the <i>NMI</i> data record. This indicates the date on which the parameters of this particular <i>NMI</i> data record apply from.	MANDATORY	Party sending transactio

Data Element Name	Description	Standing Data Required	Party to Provide
	The data applies from the beginning of this date (the start of the day, i.e. 00:00).		n
ToDate	End date of the record. This indicates the date on which the parameters of this particular record end. The data applies until the end of this date (the end of the day, i.e. 23:59). A default date of 9999-12-31 is recorded if EndDate is not provided.	MANDATORY (Defaults to high date unless supplied)	System generated unless supplied.
RowStatus	Indicates whether the record is active or inactive. Whenever a new record is created, it will be A (Active). A change to the data will make this record redundant and its MaintActFlg is changed to I (Inactive).	MANDATORY	System generated
MaintenanceDate	Date and time the record was updated. A default date of 9999-12-31 is used when the record is created initially. If the record is subsequently updated, its MaintUpdtDt is changed to the date and time the record was updated.	MANDATORY	System generated
CreationDate	Date and time the record was created.	MANDATORY	System generated

8.2. Cross Reference of Browser and aseXML Data Elements

The table below lists the names that are used in the MSATS browser. The table also provides the aseXML data element names and the respective formats used in each context.

In some cases, such as date fields, the format of the field is shown differently in the Browser to that used in the related aseXML transactions. Also, aseXML uses full words throughout, rather than the coded values used in the Browser.

Section 16 provides data type conventions of the Browser formats shown in this section.

Table 16 CATS_NMI_DATA_STREAM- Browser cross reference

Browser Field name	aseXML Data Element Name	aseXML Path	BrowserFormat	aseXMLData Type
NMI	NMI	NMI	CHAR(10)	xsd:string maxLen=10
Suffix	Suffix	ElectricityDatastream/Suffix	VARCHAR2(2)	xsd:string maxLen=2
Status Code	Status	ElectricityDatastream/Status	CHAR(1)	xsd:string maxLen=10
Average Daily Load	AverageDailyLoad	ElectricityDatastream/AverageDailyLoad	NUMBER(10)	xsd:integer
Type	DataStreamType	ElectricityDatastream/DatastreamType	CHAR(1)	xsd:string with enumeration
Profile Name	ProfileName	ElectricityDatastream/ProfileName	VARCHAR2(10)	xsd:string maxLen=10
Start Date	FromDate	FromDate	dd-mmm-yyyy	xsd:dateTime
End Date	ToDate	ToDate	dd-mmm-yyyy	xsd:dateTime
Updated On	MaintenanceDate	MaintenanceDate	dd-mmm-yyyy (Summary Screen) dd-mmm-yyyy hh:mm:ss (Detail Screen)	xsd:dateTime
Created On	CreationDate	CreationDate	dd-mmm-yyyy (Summary Screen) dd-mmm-yyyy hh:mm:ss (Detail Screen)	xsd:dateTime
Activity Status	RowStatus	RowStatus	CHAR(1)	xsd:string with enumeration

8.3. Field value examples

This section provides examples of typical sets of data element values associated with different types of *connection points*.

The data shown in each example is as shown in the Browser. This reverses the sequence of the day-month-year communicated via aseXML transactions.

Table 17 CATS_NMI_Data_Stream – Examples

Data Element Name	Browser Field Name	Basic Example	Interval Example
NMI	NMI	1100445566	2211335544
ElectricityDataStream/Suffix	Suffix	31	E1
ElectricityDataStream/Status	Status Code	A	A
ElectricityDataStream/AveragedDailyLoad	Average Daily Load	5	800
ElectricityDataStream/DataStreamType	Type	C	I
ElectricityDataStream/ProfileName	Profile Name	NSLP	NOPROF
FromDate	Start Date	31-12-2001	01-06-2005
ToDate	End Date	31-12-9999	31-12-9999
MaintenanceDate	Updated On	02-01-2004 13:27:58	31-12-9999
CreationDate	Created On	19-01-2002 17:15:23	05-06-2005 15:12:20
RowStatus	Activity Status	I	A

9. CATS_REGISTER_IDENTIFIER

9.1. Field Definitions

The CATS_Register_Identifier table contains data that is stored at the register identifier level. Information stored at this level includes the Network Tariff Code. It is updated whenever a Change Request containing inbound register identifier data is completed.

Note: References to 'LNSP' include the ENM for *child connection points*.

Table 18 CATS_REGISTER_IDENTIFIER – Field Definitions

Data Element Name	Description	Standing Data Required	Party to Provide
NMI	<i>NMI</i> . This number is unique for each <i>connection point</i> within the NEM.	MANDATORY	MPB
SerialNumber	The Meter Serial ID uniquely identifies a <i>meter</i> for a given <i>NMI</i> . Maximum 12 Characters (alpha numeric). Unique for <i>NMI</i> . Use dummy for UMCP (Type 7), logical (<i>meters</i>) and <i>non-contestable unmetered loads</i> . Except for UMCP, logical, and <i>non-contestable unmetered loads</i> , MeterSerial should be displayed on physical device also known as property number). SerialNumber to be property number if exists, otherwise the <i>meter</i> manufacturers' serial number, otherwise dummy number.	MANDATORY	MPB
RegisterID	The RegisterID is used to identify a data source that is obtained from the <i>meter</i> . A single <i>meter</i> may provide multiple data sources. If the RegisterID has a value as per the 'Datastream Suffix for Interval Metering Data' section of the NMI Procedure, then it must be the same as the Suffix field in the CATS_REGISTER_IDENTIFIER table.	MANDATORY	MPB
NetworkTariffCode	The Network Tariff Code is a free text field required. The text must match the Network Tariff Codes supplied and published by the LNSP. Must be a valid code from the CATS_Network_Tariff_Codes table.	MANDATORY	MPB
NetworkAdditional Information	Free text field.	REQUIRED	MPB
UnitOfMeasure	Code to identify the unit of measure for data held in this register.	MANDATORY	MPB

Data Element Name	Description	Standing Data Required	Party to Provide
TimeOfDay	Code to identify the time validity of register contents. As published by each LNSP.	MANDATORY	MPB
Multiplier	Multiplier required to take a register value and turn it into a value representing billable energy	MANDATORY	MPB
DialFormat	Describes the register display format. First number is the number of digits to the left of the decimal place, and the second number is the number of digits to the right of the decimal place.	MANDATORY	MPB
Suffix	<p>The Suffix field in the CATS_REGISTER_IDENTIFIER table is used to identify a physical data source that is obtained from the <i>meter</i>. The value must match the value provided in the MDFF File. The Suffix value must be unique for each meter register. The Suffix in the CATS_REGISTER_IDENTIFIER table must be valid as per Datastream suffix details specified in the NMI Procedure.</p> <ul style="list-style-type: none"> For Basic Meters, the Suffix in the CATS_REGISTER_IDENTIFIER table need not match the RegisterID in the CATS_REGISTER_IDENTIFIER table. For basic data streams, the value will be identical to the related Suffix value in the CATS_NMI_DataStream table. For Interval Meters, the Suffix in the CATS_REGISTER_IDENTIFIER table will indicate the individual datastreams: <ul style="list-style-type: none"> contributing to the Nx Suffix value in the CATS_NMI_DataStream table, or associated with the individual register level interval datastream records. 	MANDATORY	MPB
ControlledLoad	Indicates whether the <i>energy</i> recorded by this register is created under a Controlled Load regime ControlledLoad field will have "No" if register does not relate to a Controlled Load.If the register relates to a Controlled Load, it should contain a description of the Controlled Load regime.	MANDATORY	MPB
RegisterDetail/ Status	Lookup code to indicate if register is active. Must ensure that RegisterDetail/Status is not Current (C) when ElectricityMeter/Status is Removed (R). This value must correspond to a valid Register Identifier Status as specified in the MSATS Procedures: CATS Procedures.	MANDATORY	MPB

STANDING DATA FOR MSATS



Data Element Name	Description	Standing Data Required	Party to Provide
ConsumptionType	<p>Actual/Subtractive Indicator.</p> <p>Actual (A) implies volume of energy actually metered between two dates.</p> <p>Cumulative (C) indicates a Meter Reading for a specific date. A second Meter Reading is required to determine the consumption between those two Meter Reading dates.</p> <p>For an Interval Meter, ActCumInd = A.</p> <p>This value must correspond to a valid ConsumptionType from the Consumption Type Codes reference table listed in section 11.</p>	MANDATORY	MPB
Demand1	This field contains the peak demand value for summer for network Tariff purposes. Units in kW or kVA	OPTIONAL	MPB (Refers to Network Tariff Code)
Demand2	This field contains an additional demand value (not Summer period). Units in kW or kVA	OPTIONAL	MPB (Refers to Network Tariff Code)
FromDate	<p>Start date of the <i>NMI</i> data record. This indicates the date on which the parameters of this particular <i>NMI</i> data record apply from.</p> <p>The data applies from the beginning of this date (the start of the day, i.e. 00:00).</p>	MANDATORY	Participant sending transaction
ToDate	<p>End date of the record. This indicates the date on which the parameters of this particular record end. The data applies until the end of this date (the end of the day, i.e. 23:59).</p> <p>A default date of 9999-12-31 is recorded if EndDate is not provided.</p>	MANDATORY (Defaults to high date unless supplied)	System generated unless supplied.
RowStatus	<p>Indicates whether the record is active or inactive.</p> <p>Whenever a new record is created, it will be A (Active). A change to the data will make this record redundant and its MaintActFlg is changed to I (Inactive).</p>	MANDATORY	System generated

Data Element Name	Description	Standing Data Required	Party to Provide
MaintenanceDate	Date and time the record was updated. A default date of 9999-12-31 is used when the record is created initially. If the record is subsequently updated, its MaintUpdtDt is changed to the date and time the record was updated.	MANDATORY	System generated
CreationDate	Date and time the record was created.	MANDATORY	System generated

9.2. Cross Reference of Browser and aseXML Data Elements

The table below lists the names that are used in the MSATS browser. The table also provides the aseXML data element names and the respective formats used in each context.

In some cases, such as date fields, the format of the field is shown differently in the Browser to that used in the related aseXML transactions. Also, aseXML uses full words throughout, rather than the coded values used in the Browser.

Section 16 provides data type conventions of the Browser formats shown in this section.

Table 19 CATS_Register_Identifier - Browser Cross Reference

Browser Field Name	aseXML Data Element Name	aseXML Path	Browser Format	aseXML Data Type
NMI	NMI	NMI	CHAR(10)	xsd:string maxLen = 10
Meter Serial ID Meter ID (Different on two screens)	SerialNumber	SerialNumber	VARCHAR2(12)	xsd:string maxLen = 12
Register ID	RegisterID	ElectricityMeterRegisterDetail/RegisterID	VARCHAR2(10)	xsd:string maxLen = 10
Network Tariff Code	NetworkTariffCode	ElectricityMeterRegisterDetail/NetworkTariffCode	VARCHAR2(10)	xsd:string maxLen = 10
Network Tariff Additional Information	NetworkAdditionalInformation	ElectricityMeterRegisterDetail/NetworkAdditionalInformation	VARCHAR2(4000)	xsd:string

STANDING DATA FOR MSATS



Browser Field Name	aseXML Data Element Name	aseXML Path	Browser Format	aseXML Data Type
Unit of Measure	UnitOfMeasure	ElectricityMeterRegisterDetail/ UnitOfMeasure	VARCHAR2(5)	xsd:string maxLen = 5
Time of Day	TimeOfDay	ElectricityMeterRegisterDetail/ TimeOfDay	VARCHAR2(10)	xsd:string maxLen = 10
Multiplier	Multiplier	ElectricityMeterRegisterDetail/Multiplier	Number(13,5)	xsd:decimal
Dial Format	DialFormat	ElectricityMeterRegisterDetail/DialFormat	Number(4,2)	xsd:decimal minIncl = 0 maxIncl = 99.99 totdig = 4 fracdig = 2
Suffix	Suffix	ElectricityMeterRegisterDetail/Suffix	VARCHAR2(2)	xsd:string maxLen = 2
Controlled Load	ControlledLoad	ElectricityMeterRegisterDetail/ControlledLoad	VARCHAR2(100)	xsd:string maxLen = 100
Status Code	Status	ElectricityMeterRegisterDetail/ Status	CHAR(1)	xsd:string with enumeration
Actual/Cumulative Indicator	ConsumptionType	ElectricityMeterRegisterDetail/ConsumptionType	CHAR(1)	xsd:string with enumeration
Demand 1	Demand1	ElectricityMeterRegisterDetail/Demand1	Number(8)	xsd:integer totdig = 8
Demand 2	Demand2	ElectricityMeterRegisterDetail/Demand2	Number(8)	xsd:integer totdig = 8
Start Date	FromDate	FromDate	dd-mmm-yyyy	xsd:dateTime
End Date	ToDate	ToDate	dd-mmm-yyyy	xsd:dateTime

Browser Field Name	aseXML Data Element Name	aseXML Path	Browser Format	aseXML Data Type
Updated On	MaintenanceDate	MaintenanceDate	dd-mmm-yyyy (summary screen) dd-mmm-yyyy hh:mm:ss (detail screen)	xsd:dateTime
Created On	CreationDate	CreationDate	dd-mmm-yyyy (summary screen) dd-mmm-yyyy hh:mm:ss (detail screen)	xsd:dateTime
Activity Status	RowStatus	RowStatus	CHAR(1)	xsd:string with enumeration

9.3. Field value examples

This section provides examples of typical sets of data element values associated with different types of *connection points*.

The data shown in each example is as shown in the Browser. This reverses the sequence of the day-month-year communicated via aseXML transactions.

Table 20 CATS_Register_Identifier - Example

Data Element Name	Browser Field Name	Basic Example	Interval Example
NMI	NMI	1100445566	2211335544
SerialNumber	Meter Serial ID Meter ID (Different on two screens)	000012345	112258
RegisterID	Register ID	1	E1
NetworkTariffCode	Network Tariff Code	BLNB2CO	MB2RI
NetworkAdditionalInformation	Network Tariff Additional Information	General Supply Non TOU Eligible	LV TOU Demand Eligible

Data Element Name	Browser Field Name	Basic Example	Interval Example
UnitOfMeasure	Unit of Measure	KWH	KWH
TimeOfDay	Time of Day	ALLDAY	INTERVAL
Multiplier	Multiplier	1.00000	120.00000
DialFormat	Dial Format	5.00	5.10
Suffix	Suffix	11	E1
ControlledLoad	Controlled Load	YES	NO
Status	Status Code	C	C
ConsumptionType	Actual/Cumulative Indicator	C	A
Demand1	Demand 1	0	0
Demand2	Demand 2	0	0
FromDate	Start Date	01-08-2004	01-06-2005
ToDate	End Date	31-12-9999	31-12-9999
MaintenanceDate	Updated On	31-12-9999	31-12-9999
CreationDate	Created On	01-11-2005 22:30:30	05-06-2005 09:09:09
RowStatus	Activity Status	A	A

10. CATS_NMI_PARTICIPANT_RELATIONS

10.1. Field Definitions

The CATS_NMI_Participant_Relations table is a NMI master table containing data that stores the Roles that Participants play for each *NMI*. It is updated whenever a Change Request containing inbound Roles is completed. Each Role record, which contains a single Role code and a single Participant ID, has a start date and an end date, as well as information about when it was created and when it became inactive if it is no longer an active record.

Note: References to 'LNSP' include the ENM for *child connection points*.

Table 21 CATS_NMI_PARTICIPANT_RELATIONS – Field Definitions

Data Element Name	Description	Standing Data Required	Party to Provide
Party	The Participant ID whose relationship (Role) with the <i>NMI</i> is defined in this table.	MANDATORY	LNSP
NMI	<i>NMI</i> . This number is unique for each <i>connection point</i> .	MANDATORY	LNSP
Role	This defines the relationship (Role) of the Participant with the <i>NMI</i> in this table.	MANDATORY	LNSP
FromDate	Start date of the record. This indicates the date on which the parameters of this particular record apply from. The data applies from the beginning of this date (the start of the day, i.e. 00:00).	MANDATORY	Party sending transaction
ToDate	End date of the record. This indicates the date on which the parameters of this particular record end. The data applies until the end of this date (the end of the day, i.e. 23:59). A default date of 9999-12-31 is recorded if EndDate is not provided.	MANDATORY (Defaults to high date unless supplied)	System generated unless supplied.
RowStatus	Indicates whether the record is active or inactive. Whenever a new record is created, it will be A (Active). A change to the data will make this record redundant and its MaintActFlg is changed to I (Inactive).	MANDATORY	System generated
MaintenanceDate	Date and time the record was updated. A default date of 9999-12-31 is used when the record is created initially. If the record is subsequently updated, its MaintUpdtDt is changed to the date and time the record was updated.	MANDATORY	System generated
CreationDate	Date and time the record was created.	MANDATORY	System generated

10.2. Cross Reference of Browser and aseXML Data Elements

The table below lists the names that are used in the MSATS browser. The table also provides the aseXML data element names and the respective formats used in each context.

In some cases, such as date fields, the format of the field is shown differently in the Browser to that used in the related aseXML transactions. Also, aseXML uses full words throughout, rather than the coded values used in the Browser.

Section 16 provides data type conventions of the Browser formats shown in this section.

Table 22 CATS_NMI_Participant_Relations - Browser Cross Reference

Browser Field Name	aseXML Data Element Name	aseXML Path	Browser Format	aseXML Data Type
Participant ID	Party	Party	VARCHAR2(10)	xsd:string
NMI	NMI	NMI	CHAR(10)	xsd:string maxLen = 10
Role	Role	Role	VARCHAR2(4)	xsd:string maxLen = 4
Start Date	FromDate	FromDate	dd-mmm-yyyy	xsd:dateTime
End Date	ToDate	ToDate	dd-mmm-yyyy	xsd:dateTime
Updated On	MaintenanceDate	MaintenanceDate	dd-mmm-yyyy (summary screen) dd-mmm-yyyy hh:mm:ss (detail screen)	xsd:dateTime
Created On	CreationDate	CreationDate	dd-mmm-yyyy (summary screen) dd-mmm-yyyy hh:mm:ss (detail screen)	xsd:dateTime
Activity Status	RowStatus	RowStatus	CHAR(1)	xsd:string with enumeration

11. REFERENCE TABLES

Table 23 - Valid Aggregate Codes

Aggregate	Description
Y	Customer load.
N	Generator NMI.

Table 24 - Valid Consumption Type Codes

Consumptiontype	Description
A	Actual Consumption.
C	Cumulative Consumption.

Table 25 - Valid Datastream Type Codes

Datastreamtype	Description
I	Interval
C	Basic
P	Profile Data
1	Non-Market Active Import
2	Non-Market Active
3	Non-Market Reactive Import
4	Non-Market Reactive

Table 26 - Valid Profile Codes

ProfileName	Description
NSLP	<p>Net System Load Profile.</p> <p>The profile is calculated by MSATS. NSLP represents the system load after all actual <i>interval metering data</i> or specified previously-calculated profiled <i>metering data</i> that is not dependent on the NSLP has been subtracted from a known total system load and represents system-wide usage by consumption-type <i>metering installations</i>.</p>
CLOADNSWCE	<p>Controlled Load profile: Country Energy. (Now Essential Energy)</p> <p>Profile Names beginning with CLOAD are Controlled Load profiles. Controlled Load profiles are applied to Controlled Load Datastreams in NSW. There is one Controlled Load profile for each LNSP area. The names all begin with CLOADNSW to indicate that they are NSW Profile Names followed by two characters to indicate the LNSP area to which it belongs (e.g. EA = EnergyAustralia).</p>
CLOADNSWEA	Controlled Load profile: EnergyAustralia (Now Ausgrid).
CLOADNSWIE	Controlled Load profile: IntegralEnergy (Now Endeavour Energy)
QLDEGXCL31	Controlled Load profile Energex tariff 31
QLDEGXCL33	Controlled Load profile Energex tariff 33
SACLOAD	South Australian Controlled Load.
NOPROF	Used for interval Datastream types (to indicate that such Datastreams do not need to be profiled to obtain 'readings' for each <i>settlements</i> interval because the data is supplied in 30-minute intervals).

Note: Refer to the MSATS CATS Procedure section 4 for details on the valid codes for the following:

- Jurisdiction Codes
- Metering Installation Type Codes
- NMI Classification Codes
- NMI Status Codes

12. DATASTREAM STATUS CODES USE OF NMI SUFFIX TO POPULATE CATS_REGISTER_IDENTIFIER

For any particular *connection point* there may be multiple *energy* measurement elements and data recorders with multiple channels. Accurate identification of Datastreams is essential.

The NMI Procedure includes the requirements for structure of both the Suffix populated in the CATS_REGISTER_IDENTIFIER table and the ElectricityDataStream Suffix populated in the CATS_DATA_STREAM table.

The illustrations below provide context to the relationships between 'Suffix' across the MDFF Specification and CATS Procedures (specifically the CATS_REGISTER_IDENTIFIER table and CATS_DATA_STREAM tables).

Example of an Accumulated Meter 'Suffix'

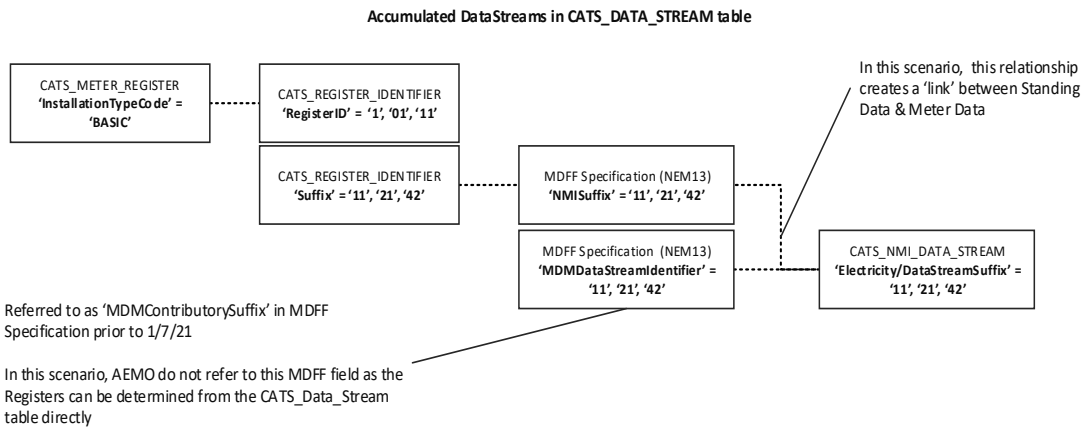

Example of an Interval Meter 'Suffix' – Net DataStreams

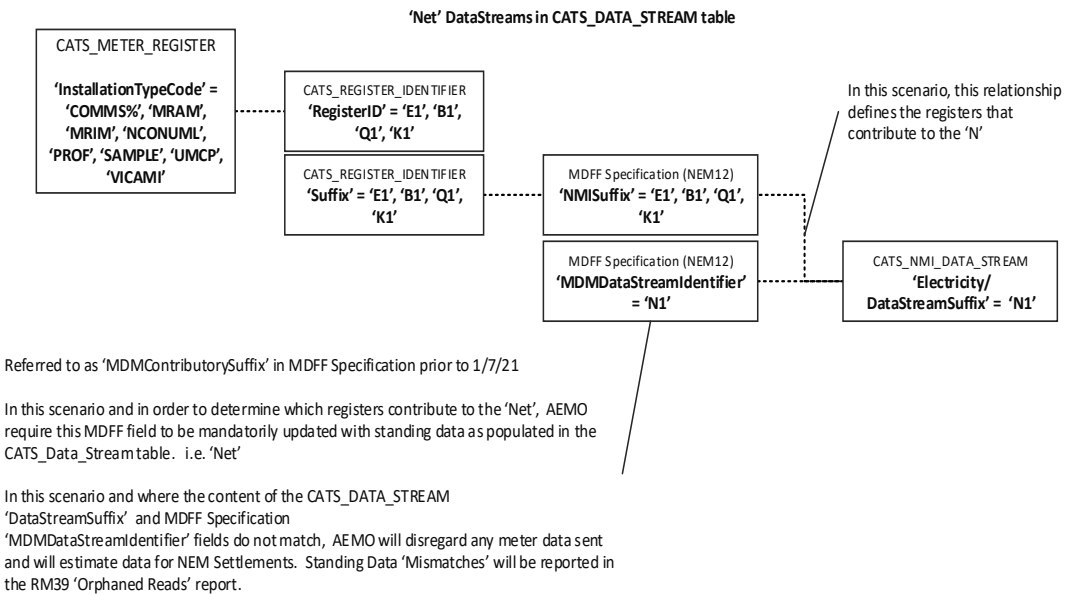

Example of an Interval Meter "Suffix" – Register Level DataStreams

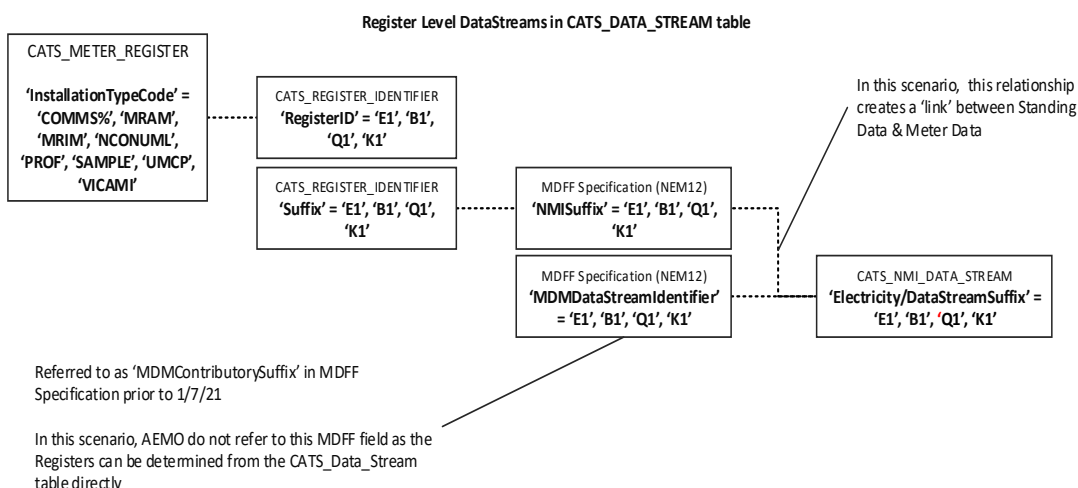

Note:

- A record must be created in the CATS_REGISTER_TABLE for each register required for settlements, profiling and UFE calculations.
- An ElectricityDataStream Suffix must be created for all individual DataStreams required for NEM Settlement calculations, profile peeloff, UFE analysis and Vic TUOS sites.

The NMI Procedure includes the requirements for the use of a suffix to the *NMI* that identifies these Datastreams. The DataStreamSuffix detailed in the NMI Procedure provides identification at the measurement element level for all Datastreams from the *connection point* identified by the *NMI*. The DataStreamSuffix is commonly known as the NMISuffix. The NMISuffix is labelled as 'Suffix' in the Browser and is the ElectricityDataStream/Suffix data element in aseXML.

12.1. Historical Information and Guideline only

The NMISuffix was first used in the NMI Procedure to describe, in conjunction with the *NMI*, the data transferred from the MDP to AEMO and Participants for *settlements*. The NMISuffix was further extended to describe Datastreams in MSATS, and numeric suffixes were developed to describe the data from type 6 *metering installations*.

In MSATS, the NMISuffix is used in the CATS_NMI_DATA_STREAM table to describe the data as delivered to AEMO. For *settlements* purposes this data must be 'NET' [Export from *network*, less import to *network*] and will be 'Nx' for an interval Datastream, or numeric for an Accumulation Meter.

In MSATS release 2.0 a new table, CATS_REGISTER_IDENTIFIER, was introduced to link identifiers for the source *meter* register(s) to the Datastream suffix in the CATS_NMI_DATA_STREAM table. The purpose of the table is to enable the alignment of the data held in MSATS and the data being transferred between Participants in the B2B process.

This link is achieved through the RegisterID (which describes the data source at the *metering installation*) and ElectricityDataStream/Suffix (which describes the NMISuffix to which the RegisterID contributes) data elements. This is a many-to-one relationship, i.e. there may be multiple RegisterID values for each ElectricityDataStream/Suffix value in the CATS_REGISTER_IDENTIFIER table.

- The RegisterID identifies the measurement element and type of measurement for an Interval Meter, and identifies the location of a stored energy value in an Accumulation Meter.

- The ElectricityDataStream/Suffix value in the CATS_NMI_DATA_STREAM table identifies the Datastream registered in MSATS. For *settlements* purposes, Interval Meter Datastreams will be the NET suffix (format Nx) and for Accumulation Meter Datastreams the suffix value is numeric. MSATS requires data to be delivered against this suffix (if the Datastream is ACTIVE). MSATS does not validate the values entered in this field.
- The ElectricityDataStream/Suffix value in the CATS_REGISTER_IDENTIFIER table identifies the individual Datastream(s) contributing to the ElectricityDataStream/Suffix value in the CATS_NMI_DATA_STREAM table. For interval Datastreams, the suffix(es) will indicate the individual Datastream(s) contributing to the Nx Suffix value in the CATS_NMI_DATA_STREAM table where the DataStreamType is P or I (Refer section 14 for examples). For accumulation Datastreams the value will be numeric and will be identical to the related Suffix value in the CATS_NMI_DATA_STREAM table (refer section 13 for examples).
- The ElectricityDataStream/Suffix values used in the CATS_REGISTER_IDENTIFIER table are used to identify *metering data* contained in MDFF Files (in the NMISuffix field).
- The linkage between the RegisterID and ElectricityDataStream/Suffix exists because the ElectricityDataStream/Suffix data element is populated in the CATS_REGISTER_IDENTIFIER table.
- The RegisterID data element has no standard format; therefore, the MPB must determine the appropriate population of this field, e.g. it may be used to indicate the programming code of the register.

There is an inconsistent understanding across industry of the meaning of the terms 'register' and 'datastream'. Conventionally, to field metering personnel, a 'register' contains a single value, while a 'datastream' represents an array of time separated register values in chronological order.

For Accumulation Meters, the RegisterID refers to the non-volatile storage of the cumulative energy register(s). The RegisterID will have identification with the displays of the *meters*, or identification of internal data stores.

For Accumulation Meters, the ElectricityDataStream/Suffix data element in the CATS_REGISTER_IDENTIFIER table may have a many-to-one relationship with the ElectricityDataStream/Suffix data element in the CATS_NMI_DATA_STREAM table. That is, the same Suffix may occur several times in the CATS_REGISTER_IDENTIFIER table and occur once only in the CATS_NMI_DATA_STREAM table.

For Interval Meters, the definition of the RegisterID field is less obvious. To make this field useful, the RegisterID should be associated with the ElectricityDataStream/Suffix. As Interval Meters may have multiple measurement elements and there may be multiple *meters* for a *NMI*, the MDP must manage Datastreams against a *NMI* to avoid duplication of ElectricityDataStream/Suffixes and provide correct mapping of RegisterIDs.

13. ASSIGNMENT OF DATA – ACCUMULATION METERS

This section details examples of the assignment of data for various basic *metering installations*. For Accumulation Meters, the Suffix values in CATS_REGISTER_IDENTIFIER and CATS_NMI_DATA_STREAM tables are always numeric.

13.1. Single Meter, no controlled load

A Accumulation Meter with a single register measuring a Non-Controlled Load will have a single Datastream suffix 11 for the *NMI*.

Table 27 Example CATS_NMI_DATA_STREAM

Data Element:	NMI	Suffix	ElectricityDataStream/Status	DataStreamType
Value	0123456789	11	A	C

The CATS_REGISTER_IDENTIFIER table indicates that the *meter* has only one register. The Suffix in the CATS_REGISTER_IDENTIFIER '11' denotes that data from RegisterID 01 contributes to the Datastream identified by Suffix 11 in CATS_NMI_DATA_STREAM table.

Table 28 Example CATS_REGISTER_IDENTIFIER

Data Element:	Serial Number	RegisterID	UnitOfMeasure	TimeOfDay	Suffix	Controlled Load
Value	ABCD1111	01	KWH	ALLDAY	11	No

The ElectricityDataStream Suffix in CATS_NMI_DATA_STREAM table will be recorded as '11' by the MDP and the Suffix in CATS_REGISTER_IDENTIFIER table must then be '11'.

13.2. Two Single Element Meters, no controlled load

The *NMI* has two Accumulation Meters, each *meter* with single register. The data from the two *meters* will be submitted to MSATS as two Datastreams.

Table 29 Example CATS_NMI_DATA_STREAM

Data Element:	NMI	Suffix	ElectricityDataStream/Status	DataStreamType
Values	0123456789	11	A	C
	0123456789	12	A	C

Table 30 Example CATS_REGISTER_IDENTIFIER

Data Element:	Serial Number	RegisterID	UnitOfMeasure	TimeOfDay	Suffix	Controlled Load
Values	ABCD1111	01	KWH	ALLDAY	11	No
	XYZA1112	01	KWH	ALLDAY	12	No

13.3. Two Single Element Meters, one with controlled load

A *NMI* has two Accumulation Meters, each *meter* has a single register, and one *meter* is measuring a Controlled Load. The data from the two *meters* is submitted to MSATS as two ElectricityDataStream Suffixes.

Table 31 Example CATS_NMI_DATA_STREAM

Data Element:	NMI	Suffix	ElectricityDataStream/Status	DataStreamType
Value	0123456789	11	A	C
	0123456789	42	A	C

Table 32 Example CATS_REGISTER_IDENTIFIER

Data Element:	Serial Number	RegisterID	UnitOfMeasure	TimeOfDay	Suffix	Controlled Load
Values	ABCD1111	01	KWH	TOTAL	11	No
	XYZA1112	01	KWH	CL1	42	HWLoad

13.4. One Meter with Two Registers, one measuring a controlled load

NMI has one Accumulation Meter with two registers. The second register is measuring a Controlled Load.

Table 33 Example CATS_NMI_DATA_STREAM

Data Element:	NMI	Suffix	ElectricityDataStream/Status	DataStreamType
Value	0123456789	11	A	C
	0123456789	42	A	C

Table 34 Example CATS_REGISTER_IDENTIFIER

Data Element:	Serial Number	RegisterID	UnitOfMeasure	TimeOfDay	Suffix	Controlled Load
Value	ABCD1111	01	KWH	PEAK	11	No
	ABCD1111	02	KWH	CL1	41	HWLoad

13.5. Single Multi-function Meter

Accumulation Meter has 4 registers, one register being a Controlled Load.

Table 35 Example CATS_NMI_DATA_STREAM

Data Element:	NMI	Suffix	ElectricityDataStream/Status	DataStreamType
Values	0123456789	11	A	C
	0123456789	21	I	C
	0123456789	31	A	C
	0123456789	41	A	C

Each register is separately identified in CATS_NMI_Data_Stream. However, register 2 on *meter 1* is inactive in MSATS.

Table 36 Example CATS_REGISTER_IDENTIFIER

Data Element:	Serial Number	RegisterID	UnitOfMeasure	TimeOfDay	Suffix	Controlled Load
Values	ABCD1111	01	KWH	ALLDAY	11	No
	ABCD1111	02	KWH	NOTUSED	21	No
	ABCD1111	03	KWH	OFFPEAK	31	No
	ABCD1111	04	KWH	CL1	41	HWLoad

Note: The *meter* may have register identification and therefore these numbers can be used in the table as RegisterID.

13.6. Two meters, three registers. One register measures a controlled load

Table 37 Example CATS_NMI_DATA_STREAM

Data Element:	NMI	Suffix	ElectricityDataStream/Status	DataStreamType
Values	0123456789	11	A	C
	0123456789	21	A	C
	0123456789	42	A	C

Table 38 Example CATS_REGISTER_IDENTIFIER

Data Element:	Serial Number	RegisterID	UnitOfMeasure	TimeOfDay	Suffix	Controlled Load
Values	ABCD1111	01	KWH	PEAK	11	No
	ABCD1111	02	KWH	OFFPEAK	21	No
	XYZA1112	01	KWH	CL1	42	HWLoad

14. ASSIGNMENT OF DATA – INTERVAL METERS

This section details examples of the assignment of data for various Interval Meters.

14.1. One meter

Table 39 Example CATS_NMI_DATA_STREAM

Data Element:	NMI	Suffix	ElectricityDataStream/Status	DataStreamType
Value	0123456789	E1	A	I

The CATS_Register_Identifier table indicates that the *meter* has only one register. The Suffix in the CATS_REGISTER_IDENTIFIER [E1] denotes that data from RegisterID 01 contributes to the ElectricityDataStream Suffix identified by Suffix E1 in the CATS_NMI_DATA_STREAM table.

Table 40 Example CATS_REGISTER_IDENTIFIER

Data Element:	Serial Number	RegisterID	UnitOfMeasure	TimeOfDay	Suffix
Value	ABCD1111	01	KWH	INTERVAL	E1

E1 indicates that it is a single element measuring export.

14.2. Import/Export meter

Interval Meter has a two registers, registering import and export *energy*. Multiple ElectricityDataStream Suffixes (E1 and B1) are defined for the *NMI*.

Table 41 Example CATS_NMI_DATA_STREAM

Data Element:	NMI	Suffix	ElectricityDataStream/Status	DataStreamType
Value	0123456789	N1	A	I
Value	0123456789	B1	A	I

The CATS_REGISTER_IDENTIFIER table indicates that the *meter* has two registers, one for IMPORT and one for EXPORT.

Table 42 Example CATS_REGISTER_IDENTIFIER

Data Element:	Serial Number	RegisterID	UnitOfMeasure	TimeOfDay	Suffix
Values	ABCD1111	E1	KWH	INTERVAL	E1
	ABCD1111	B1	KWH	INTERVAL	B1

Only one RegisterID with the Suffix 'E1' permitted per *meter* in CATS_REGISTER_IDENTIFIER.

Only one RegisterID with the Suffix 'B1' permitted per *meter* in CATS_REGISTER_IDENTIFIER.

14.3. One meter: multiple registers

Interval Meter has a single measurement element registering import and export *energy*, reactive and *voltage*.

Table 43 Example CATS_NMI_DATA_STREAM

Data Element:	NMI	Suffix	ElectricityDataStream/Status	DataStreamType
Value	0123456789	N1	A	I
Value	0123456789	B1	A	I
Value	0123456789	Q1	A	N
Value	0123456789	K1	A	N

The CATS_Register_Identifier table indicates that the *meter* has five registers: two for IMPORT of *energy* and reactive; two for EXPORT of *energy* and reactive; and one for *voltage* monitoring.

Data Element:	Serial Number	RegisterID	UnitOfMeasure	TimeOfDay	Suffix
Values	ABCD1111	E1	KWH	INTERVAL	E1
	ABCD1111	B1	KWH	INTERVAL	B1
	ABCD1111	Q1	KVARH	INTERVAL	Q1
	ABCD1111	K1	KVARH	INTERVAL	K1
	ABCD1111	V1	VOLTS	INTERVAL	V1

14.4. One meter: Twin Measurement Elements

Certain multifunction *meters* have the capability for initial installation as an Accumulation Meter, but can be re-programmed to provide *interval metering data*.

The NER do not permit the use of two different types of *metering installation* on the one *NMI*, and therefore these two *metering* functions MUST NOT be active simultaneously in MSATS. The MDP and RP will be held accountable for a breach of this requirement.

The CATS_REGISTER_IDENTIFIER can be used to record the *meter* capability.

The CATS_REGISTER_IDENTIFIER table values for this *meter* when it is operated as an Interval Meter are shown below. The RegisterID for the Accumulation Meter registers in this type of *meter* are user defined. The Interval Meter suffixes must be added to the *NMI* and made active, and the basic Suffixes made inactive at the same date.

Table 44 Example CATS_NMI_DATA_STREAM

Data Element:	NMI	Suffix	ElectricityDataStream/Status	DataStreamType
Values	0123456789	E1	A	I
	0123456789	E2	A	I
	0123456789	11	I	C
	0123456789	21	I	C
	0123456789	31	I	C
	0123456789	41	I	C

Table 45 Example CATS_REGISTER_IDENTIFIER

Data Element:	Serial Number	RegisterID	UnitOfMeasure	TimeOfDay	Suffix
Values	AB888888	E1	KWH	INTERVAL	E1
	AB888888	E2	KWH	INTERVAL	E2
	AB888888	11	KWH	PEAK	11
	AB888888	21	KWH	SHOULDER	21
	AB888888	31	KWH	OFFPEAK	31
	AB888888	41	KWH	CL1	41

If a second *meter* of the same configuration were established on this *NMI*, 'E3' and 'E4' RegisterIDs in the CATS_REGISTER_IDENTIFIER table and ElectricityDataStream Suffixes in the CATS_DATA_STREAM table would be required in order to provide unambiguous identification of Datastreams.

14.5. NCONUML and UMCP

Table 46 Example CATS_NMI_DATA_STREAM

Data Element:	NMI	Suffix	ElectricityDataStream/Status	DataStreamType
Values	1144885588	E1	A	I

Table 47 Example CATS_REGISTER_IDENTIFIER

Data Element:	Serial Number	RegisterID	UnitOfMeasure	TimeOfDay	Suffix
Values	Dummy Value	E1	KWH	INTERVAL	E1

15. ASSIGNMENTS OF DATA – SAMPLE METERS

The application of profiles in accordance with the Metrology Procedure requires *interval metering data* from Sites that have Accumulation Metering. However, the NER do not permit different metering installation types on the one *NMI*, and in any case, the Participants associated with the *interval metering data* are different to those associated with the Accumulation Meter. Therefore, for these *connection points*, two different *NMIs* are used.

There are *meters* that can combine the required Accumulation Metering and Interval Metering functions. An example is shown below.

15.1. Multifunction Sample Meter

In this case, a single *meter* is registered within MSATS for two purposes against two *NMIs*. This is a special case, and should not be used other than for this non-standard purpose. The *meter* has two circuits, with Accumulation Metering for *energy* trading and Interval Metering for the sample profile.

In this example, NMI 9801234567 is associated with the sample *meter installation* and NMI 9876543210 with the End User installation.

Table 48 Example CATS_NMI_DATA_STREAM

Data Element:	NMI	Suffix	ElectricityDataStream/Status	DataStreamType
Values	9801234567	N1	A	P
	9876543210	11	I	C
	9876543210	12	I	C
	9876543210	41	A	C

Table 49 Example CATS_REGISTER_IDENTIFIER

Data Element:	NMI	MeterSerial	RegisterID	UnitOfMeasure	TimeOfDay	Suffix
Values	9801234567	AB888888	E1	KWH	INTERVAL	E1
	9876543210	AB888888	11	KWH	PEAK	null
	9876543210	AB888888	12	KWH	OFFPEAK	null
	9876543210	AB888888	41	KWH	CL1	41

16. DATA TYPE CONVENTIONS

The Browser formats used in section 16 are as defined in the following table.

The value of “x” must be positive and cannot be zero.

For explanation of the aseXML data types shown in section 16 refer

<http://www.w3.org/TR/xmlschema-0/#simpleTypesTable>

Table 50 BROWSER FORMATS

	Format	Definition
1	CHAR(x)	Indicates a field that can only contain alphanumeric characters and must contain exactly "x" characters. Note that leading and trailing "spaces" are considered significant (i.e. form part of the "x" characters for the field).
2	VARCHAR2(x)	Indicates a character field containing up to "x" characters.
3	NUMBER(x)	Indicates a positive integer (zero or above) up to "x" significant digits long; any leading zeroes are not significant and hence "050" is equivalent to "50".
4	NUMBER(x,y)	Indicates a positive number with up to "x" significant characters to the left of the decimal point and "y" decimal places after the decimal point (trailing zeros are optional). In other words, the maximum length of the field as a whole is "x"+"y"+1 characters (the +1 reserving space for the decimal point).