



# POWER SYSTEM MODEL GUIDELINES

PREPARED BY: Operational Analysis and Engineering, AEMO  
VERSION: 0.1  
EFFECTIVE DATE: ~~5 March 2018~~ [14 May 2018](#)  
STATUS: Draft for consultation

Approved for distribution and use by:

APPROVED BY: Damien Sanford  
TITLE: Executive General Manager, Operations

DATE: ~~5 March 2018~~ [14 May 2018](#)





# VERSION RELEASE HISTORY

Version	Effective Date	Summary of Changes
0.1	5 Mar 2018	Draft for consultation
<a href="#">0.2</a>	<a href="#">14 May 2018</a>	<a href="#">Updated draft following stage 1 of consultation.</a>



# CONTENTS

<b>TABLES</b>	<b>4</b>
<b>FIGURES</b>	<b>4</b>
<b>1. INTRODUCTION</b>	<b>5</b>
1.1 Purpose	5
1.2 Definitions and interpretation	5
1.3 Related documents	7
1.4 Context	7
<b>2. PROVISION OF MODELS AND OTHER INFORMATION</b>	<b>9</b>
2.1 Generators	9
2.2 Network Service Providers	10
2.3 Network Users	10
2.4 Market Network Service Providers	10
2.5 Prospective NSCAS Tenderers	11
2.6 Prospective SRAS Providers	11
<b>3. MODELS AND DATA REQUIREMENTS</b>	<b>11</b>
3.1 Generators, NSPs, Network Users, and MNSPs	11
3.2 NSCAS Tenderers and SRAS Providers	12
3.3 Exemptions	12
<b>4. MODEL ADEQUACY</b>	<b>20</b>
4.1 Load flow model requirements	22
4.2 Fault level model requirements	22
4.3 RMS and EMT stability model requirements	23
4.4 Conventional EMT model requirements	32
4.5 Small-signal model requirements	33
4.6 Power quality model requirements	34
4.7 Model aggregation	35
4.8 Model and plant updates	38
<b>5. MODEL DOCUMENTATION</b>	<b>39</b>
5.1 Releasable User Guide	40
5.2 RMS and EMT Model Documentation	40
5.3 Small signal stability model documentation	41
5.4 Harmonic model documentation	42
<b>6. MODEL ACCURACY REQUIREMENTS</b>	<b>42</b>
6.1 Accuracy locations	42
6.2 Model performance measures	42
6.3 Model validation and confirmation	45
6.4 Non-conformance with model accuracy requirements	47
<b>7. CONFIDENTIALITY OF INFORMATION AND MODELS PROVIDED</b>	<b>48</b>
7.1 Storage and use by AEMO	48
7.2 Intellectual property	48



7.3	EMT model black-boxing, compilation or encryption	48
7.4	Provision of information and models to third parties	48
<b>8.</b>	<b>ALTERNATIVE PROCESS</b>	<b>50</b>
8.1	Generally	50
8.2	Examples of Requests	50
8.3	Consideration of Request	50
8.4	Determination	51
<b>APPENDIX A. APPLICATION FOR EXEMPTION FROM THE REQUIREMENT TO PROVIDE MODEL AND OTHER INFORMATION</b>		<b>52</b>
<b>APPENDIX B. APPLICATION TO PROVIDE ALTERNATIVE MODEL OR INFORMATION</b>		<b>53</b>
<b>APPENDIX C. MODELLING COMPONENT REQUIREMENTS</b>		<b>54</b>
C.1	Definitions and notes	54
C.2	Wind generation	55
C.3	Photovoltaic generation	57
C.4	Converter-based energy storage systems	58
C.5	High voltage DC link	60
C.6	Synchronous machines and generators	61
C.7	Converter-based reactive support systems	62
<b>APPENDIX D. QUANTITIES TO BE ASSESSED FOR TRANSIENT AND VOLTAGE ANALYSIS</b>		<b>64</b>
<b>APPENDIX E. TRANSIENT WINDOW DEFINITIONS</b>		<b>67</b>
E.1	Transient window for an uncontrolled change	67
E.2	Transient window for a controlled change	68
<b>TABLES</b>		
Table 1	Defined Terms	5
Table 2	Grounds on which exemption may be granted	12
Table 3	Load flow model inclusions	22
Table 4	Required model output quantities	29
Table 5	Simulation tools required for R2 model validation	46
Table 6	Models to be provided by AEMO	49
<b>FIGURES</b>		
Figure 1	Interrelationship of System Security Market Framework components	8
Figure 2	Aggregated and Black-Boxed EMT model high level representation	38



## 1. INTRODUCTION

### 1.1 Purpose

These are the *Power System Model Guidelines (Guidelines)* made under clause S5.5.7(a)(3) of the National Electricity Rules (NER). They specify AEMO's requirements concerning the information and models that *Generators*, NSPs, *Network Users*, MNSPs, prospective NSCAS tenderers and prospective SRAS Providers (**Applicants**) must provide to AEMO and NSPs in specified circumstances.

AEMO requires this information and models to develop mathematical models for *plant*, including the impact of their *control systems* and *protection systems* on *power system security*.

These Guidelines have effect only for the purposes set out in the NER. The NER and the *National Electricity Law* prevail over these Guidelines to the extent of any inconsistency.

### 1.2 Definitions and interpretation

#### 1.2.1 Glossary

The words, phrases and abbreviations in Table 1 have the meanings set out opposite them when used in these Guidelines.

Terms defined in the *National Electricity Law* and the NER have the same meanings in these Guidelines unless otherwise specified in this Section 1.2.1.

Terms defined in the NER are intended to be identified in these Guidelines by italicising them, but failure to italicise a defined term does not affect its meaning.

**Table 1 Defined Terms**

Term	Definition
Applicants	<i>Generators</i> , NSPs, <i>Network Users</i> , MNSPs, prospective NSCAS tenderers and prospective SRAS Providers to whom these Guidelines apply.
AGC	Automatic generation control
AVR	Automatic voltage regulator
BFP	Boiler feed-pump
CT	Current Transformer
Data Sheets	The <i>Power System Design Data Sheets</i> and <i>Power System Setting Data Sheets</i>
DC	Direct Current
Disturbance	<p><u>Any, or a combination of more</u> of the following:</p> <ul style="list-style-type: none"> <li>• A balanced or unbalanced fault remote from a <i>connection point</i>.</li> <li>• A balanced or unbalanced fault at, or close to, a <i>connection point</i>.</li> <li>• A <i>transmission line</i>, <i>distribution line</i> or other <i>plant</i> switching or tripping;</li> <li>• A trip, with or without a fault, of one or more <i>generating units</i> (from the same, or another <i>generating system</i>) or <i>Customer loads</i>.</li> <li>• A short or long <i>voltage</i> disturbance (e.g. as could occur when a part of the <i>network</i> is close to <i>voltage</i> collapse).</li> <li>• A <i>frequency</i> disturbance (e.g. as could occur when a part of the <i>network</i> is islanded).</li> <li>• <u>Rapid changes in the energy source available to the <i>plant</i> (e.g. as could occur when cloud cover affects PV energy availability).</u></li> <li>• <u>Voltage phase angle jumps (e.g. as could occur when large load or generation is suddenly lost in the <i>network</i>).</u></li> <li>• <u>Changes to the energy source available to the <i>plant</i> (e.g. as could occur when cloud cover affects PV energy availability)</u></li> </ul>
DLL	Dynamically linked library
DSA	Dynamic security assessment
EMT	Electromagnetic transients
FACTS	Flexible AC <i>transmission systems</i>
FCAS	<i>Frequency control ancillary services</i>

Term	Definition
FDF	Forced Draft Fan
FRT	Fault ride-through
HIL	Hardware-in-loop
HV	High voltage
HVDC	High voltage direct current
HVRT	High voltage ride-through
IDF	Induced Draft Fan
IGBT	Insulated gate bipolar transistor
kHz	Kilo-Hertz
LCC	Line-Commutated Converter
LV	Low voltage
LVRT	Low voltage ride-through
MBASE	Machine Base Mega Volt Ampere
MNSP	<i>Market Network Service Provider</i>
ms	millisecond
MVA	Mega Volt Ampere
MV	Medium voltage
NER	<i>National Electricity Rules</i>
NSP	<i>Network Service Provider</i>
OLTC	On load tap changer
OPDMS	Operations and Planning Data Management System
PCC	Point of common coupling
PI	Proportional integral
PID	Proportional integral derivative
PLC	Programmable Logic Controller
PLL	phase locked loop
POD	Power oscillation damper
Post-Contingent Steady State	The condition of a <i>power system</i> immediately after a Disturbance, when <i>power system</i> electrical quantities have obtained steady values following the action of fast-acting <i>plant</i> and <i>network</i> controls, but other slower-acting <i>control systems</i> may not yet have operated.
PPC	Power plant controller (also known as 'power park controller')
PSCAD™/EMTDC™	Power Systems Computer Aided Design / Electromagnetic Transient with Direct Current
PSS	Power System Stabiliser
PSS@E	Power System Simulator for Engineering
PWM	Pulse width modulation
Quasi-Steady state	Physically dynamic phenomena that can be represented in simulation using static analysis.
R2	Registered data after <i>connection</i> , as derived from on-system testing and designated as 'R2' in the Data Sheets and as described further in clause S5.5.6 of the NER.
RMS	Root mean square
RUG	<i>releasable user guide</i>
SCADA	Supervisory control and data acquisition
SCR	Short circuit ratio
SMIB	Single machine and infinite bus (simplified network model)
SSCI	Sub-synchronous control interaction
SSR	Sub-synchronous resonance
SSTI	Sub-synchronous torsional interaction
STATCOM	Static compensator

Term	Definition
Steady State	The electrical conditions prevailing in any 50Hz <i>power system</i> after decay of transients, under either normal or contingency operating conditions and in the absence of short circuits, where the RMS variables of the <i>power system</i> (such as <i>voltage</i> and <i>current</i> ) are unchanging in time.
SVC	<i>static VAR compensator</i>
TNSP	<i>Transmission Network Service Provider</i>
TOV	Temporary overvoltages
TTHL	Trip to house load
Type 3	(Wind Turbine) A doubly-fed induction generator type
Type 4	(Wind Turbine) A back-to-back converter type
UPS	Uninterruptible power supply
VT	Voltage Transformer

### 1.2.2 Interpretation

The following principles of interpretation apply to these Guidelines unless otherwise expressly indicated:

- (a) These Guidelines are subject to the principles of interpretation set out in Schedule 2 of the *National Electricity Law*.
- (b) The words “includes”, “including” or “such as” are not words of limitation, and when introducing an example, do not limit the meaning of the words to which the example relates to examples of a similar kind.

### 1.3 Related documents

Title	Location
NSCAS Tender Guidelines	<a href="https://www.aemo.com.au/Electricity/National-Electricity-Market-NEM/Security-and-reliability/Ancillary-services/Network-support-and-control-ancillary-services-procedures-and-guidelines">https://www.aemo.com.au/Electricity/National-Electricity-Market-NEM/Security-and-reliability/Ancillary-services/Network-support-and-control-ancillary-services-procedures-and-guidelines</a>
Power System Design Data Sheets	TBA
Power System Setting Data Sheets	TBA
SRAS Guidelines	<a href="https://www.aemo.com.au/Stakeholder-Consultation/Consultations/SRAS-Guidelines-2017">https://www.aemo.com.au/Stakeholder-Consultation/Consultations/SRAS-Guidelines-2017</a>
System Strength Impact Assessment Guidelines	TBA

### 1.4 Context

These Guidelines and the Data Sheets are tools that enable AEMO and the NSPs to implement a number of obligations under the NER, especially those that relate to meeting AEMO’s *power system security responsibilities* and the management of new *connections* to the *national grid*.

Figure 1 shows the interrelationship between these Guidelines and other NER instruments and AEMO guidelines, operating procedures and activities. By no means a complete depiction, it highlights the criticality of compliance by affected *Registered Participants* with these Guidelines by showing how they relate to key obligations imposed on AEMO and NSPs in the context of *power system security*.

**Figure 1 Interrelationship of System Security Market Framework components**

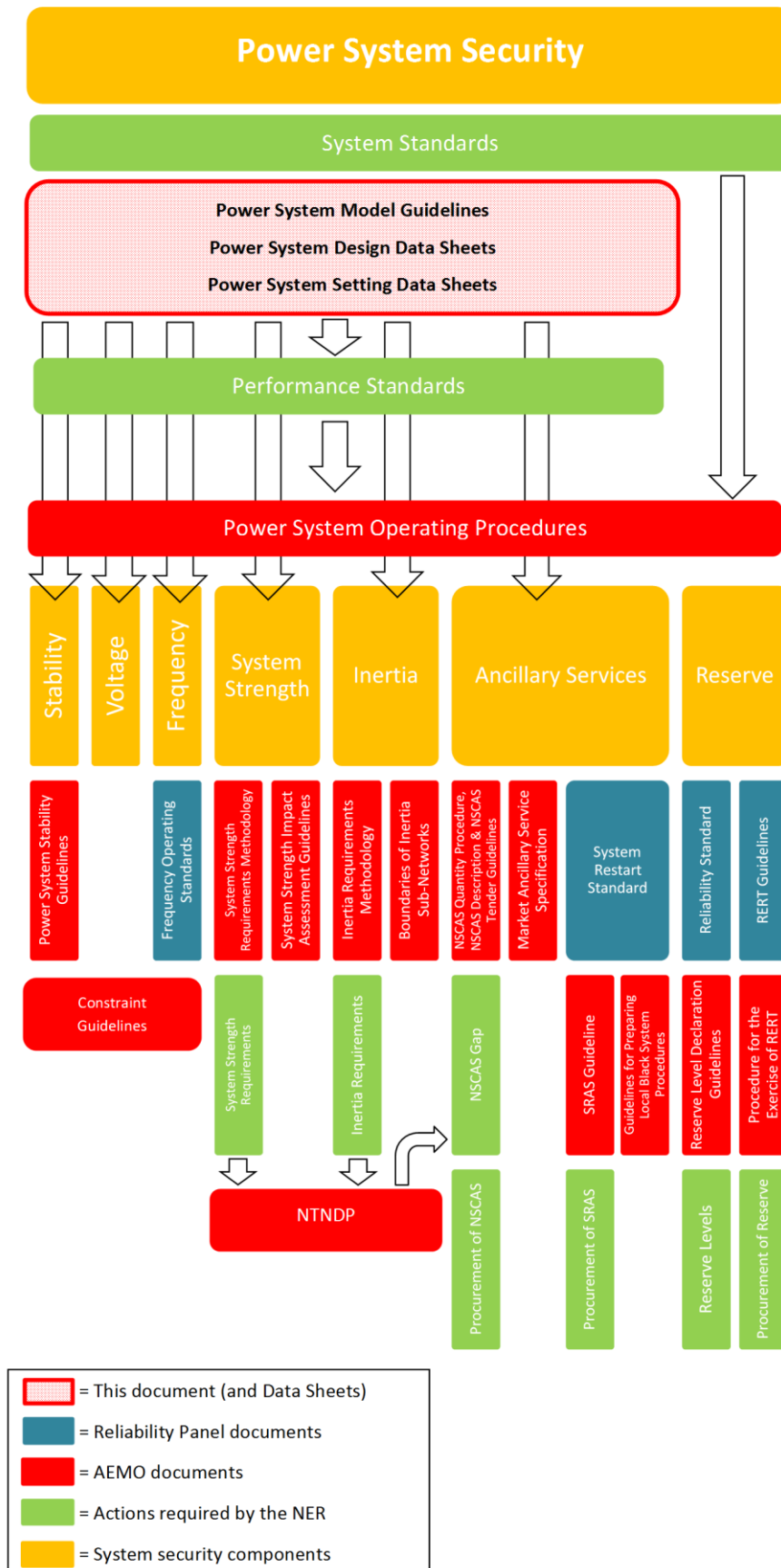



## 2. PROVISION OF MODELS AND OTHER INFORMATION

### 2.1 Generators

The circumstances in which *Generators* must provide models and other information to AEMO and NSPs in respect of their *generating systems* under these Guidelines are specified in clause S5.5.7(b1)(1)(i) of [the NER](#) and are, in summary:

Requirement	Timing
(a) Where there is, in AEMO's reasonable opinion, a risk that a <i>Generator's plant</i> will: <ol style="list-style-type: none"> <li>(1) adversely affect network capability, power system security, quality or reliability of supply, inter-regional power transfer capability;</li> <li>(2) adversely affect the use of a <i>network</i> by a <i>Network User</i>; or</li> <li>(3) have an adverse system strength impact<sup>1</sup>.</li> </ol>	Within 20 <i>business days</i> of AEMO's notice of the impact described in sub-paragraph (1), (2) or (3).
(b) Where, in AEMO's reasonable opinion, information of the type described in clause S5.2.4 of the NER is required to enable an NSP to conduct a <i>system strength impact assessment</i> <sup>2</sup> .	Within 15 <i>business days</i> of AEMO's request to provide the relevant information.
(c) Where the <i>Generator</i> is proposing an alteration to a <i>generating system</i> for which <i>performance standards</i> have been agreed and the alteration will: <ol style="list-style-type: none"> <li>(1) affect the <i>generating system's</i> performance relative to any of the technical requirements in clauses S5.2.5, S5.2.6, S5.2.7 and S5.2.8 of the NER; or</li> <li>(2) in AEMO's reasonable opinion:                             <ol style="list-style-type: none"> <li>(A) have an <i>adverse system strength impact</i>; or</li> <li>(B) adversely affect <i>network</i> capability, quality or reliability of <i>supply</i>, <i>inter-regional power transfer capability</i> or the use of a <i>network</i> by another <i>Network User</i><sup>3</sup>.</li> </ol> </li> </ol>	Within 20 <i>business days</i> of AEMO's notice of the impact described in sub-paragraph (1) or (2).
(d) When negotiating a <i>connection agreement</i> <sup>4</sup> .	With the <i>application to connect</i> submitted under clause 5.3.4 of the NER.
(e) When connecting a generating system <30 MW, or generating units totalling <30MW to a connection point on a distribution network <sup>5</sup> .	With the <i>application to connect</i> submitted under clause 5.3.4 of the NER.

AEMO needs to be able to model *power system* behaviour on an ongoing basis to ensure that it can fulfil its obligations to operate the *power system* in accordance with the NER. To achieve this, AEMO needs up-to-date information about the behaviour of *plant connected* to the *power system*. *Generators* should ensure that all models and other information provided to AEMO in accordance with these Guidelines remain up to date, because if AEMO reasonably considers that:

- the analytic parameters for modelling of a *generating unit* or *generating system* are inadequate; or
- available information, including results from a test of a *generating unit* or *generating system* under clause 5.7.6(a) of the NER, are inadequate to determine parameters for an applicable model,

AEMO may direct an NSP to require a *Generator* to conduct a test under clause 5.7.6(a) at the *Generator's* cost.

Furthermore, a *Generator* who has previously provided adequate RMS models and associated information to AEMO will be required to provide up-to-date EMT models if required by an NSP who carries

<sup>1</sup> See clause 5.2.5(d) of the NER. See also footnote 2 for further information about *system strength impact assessments*.

<sup>2</sup> See clause 5.2.5(e) of the NER. Where a *Generator* has previously provided an RMS model to AEMO, that model will be inadequate for carrying out a full *system strength impact assessment* and an EMT model will be required. For further information about full *system strength impact assessments*, see the System Strength Assessment Guidelines.

<sup>3</sup> See clause 5.3.9(b)(2) of the NER.

<sup>4</sup> See clause S5.2.4 of the NER.

<sup>5</sup> See clause S5.5.6 of the NER.

out a *system strength impact assessment*, as these are the only types of models that will result in an accurate assessment.

## 2.2 Network Service Providers

The circumstances in which NSPs must provide models and other information to AEMO in respect of their *network elements* under these Guidelines are specified in clause S5.5.7(b1)(1)(ii) [of the NER](#) and are, in summary:

Requirement	Timing
(a) Where there is, in AEMO's reasonable opinion, a risk that an alteration to a <i>network element</i> or the <i>connection</i> of any new or additional equipment to the <i>network</i> will: <ol style="list-style-type: none"> <li>(1) adversely affect network capability, power system security, quality or reliability of supply, inter-regional power transfer capability; or</li> <li>(2) adversely affect the use of a <i>network</i> by a <i>Network User</i><sup>6</sup>.</li> </ol>	Within 20 <i>business days</i> of AEMO's notice of the impact described in sub-paragraph (1) or (2).
(b) Where there is, in AEMO's reasonable opinion, a risk that an NSP's <i>plant</i> or equipment will: <ol style="list-style-type: none"> <li>(1) adversely affect network capability, power system security, quality or reliability of supply, inter-regional power transfer capability;</li> <li>(2) adversely affect the use of a <i>network</i> by a <i>Network User</i>; or</li> <li>(3) have an adverse system strength impact<sup>7</sup>.</li> </ol>	Within: <ul style="list-style-type: none"> <li>• 20 <i>business days</i> of AEMO's notice of the impact described in sub-paragraph (1) or (2); or</li> <li>• 15 <i>business days</i> of AEMO's notice of the impact described in sub-paragraph (3).</li> </ul>
(c) Where, in AEMO's reasonable opinion, information of the type described in clause 4.2.4(o) is required to enable another NSP to conduct a <i>system strength impact assessment</i> <sup>8</sup> .	Within 15 <i>business days</i> of AEMO's request to provide the relevant information.

## 2.3 Network Users

The circumstances in which *Network Users* must provide models and other information to AEMO in respect of their *plant* under these Guidelines are specified in clause S5.5.7(b1)(i)(iii) [of the NER](#) and are, in summary:

Requirement	Timing
(b) Where there is, in AEMO's reasonable opinion, a risk that a <i>Network User's plant</i> will: <ol style="list-style-type: none"> <li>(1) adversely affect network capability, power system security, quality or reliability of supply, inter-regional power transfer capability;</li> <li>(2) adversely affect the use of a <i>network</i> by a <i>Network User</i>; or</li> <li>(3) have an <i>adverse system strength impact</i><sup>9</sup>.</li> </ol>	Within: <ul style="list-style-type: none"> <li>• 20 <i>business days</i> of AEMO's notice of the impact described in sub-paragraph (1) or (2); or</li> <li>• 15 <i>business days</i> of AEMO's notice of the impact described in sub-paragraph (3).</li> </ul>
(b) Where, in AEMO's reasonable opinion, information of the type described in clause S5.3.1(a1) of the NER is required to enable an NSP to conduct a <i>system strength impact assessment</i> <sup>10</sup> .	Within 15 <i>business days</i> of AEMO's request to provide the relevant information.
(c) Before <i>connecting</i> any new or additional equipment to a <i>network</i> <sup>11</sup> .	With the <i>application to connect</i> submitted under clause 5.3.4 of the NER.

## 2.4 Market Network Service Providers

The circumstances in which MNSPs must provide models and other information to AEMO in respect of their *plant* or equipment under these Guidelines are specified in clause S5.5.7(b1)(1)(iv) [of the NER](#) and are, in summary:

<sup>6</sup> See clause 4.3.4(o) of the NER.

<sup>7</sup> See clause 5.2.3(j) of the NER.

<sup>8</sup> See clause 5.2.3(k) of the NER.

<sup>9</sup> See clause 5.2.4(c) of the NER.

<sup>10</sup> See clause 5.2.4(d) of the NER.

<sup>11</sup> See clause S5.3.1(a1) of the NER.

Requirement	Timing
(a) Where there is, in AEMO's reasonable opinion, a risk that MNSPs' <i>plant</i> or equipment will: <ol style="list-style-type: none"> <li>(1) adversely affect network capability, power system security, quality or reliability of supply, inter-regional power transfer capability;</li> <li>(2) adversely affect the use of a <i>network</i> by a <i>Network User</i>, or</li> <li>(3) have an <i>adverse system strength impact</i><sup>12</sup>.</li> </ol>	Within: <ul style="list-style-type: none"> <li>• 20 <i>business days</i> of AEMO's notice of the impact described in sub-paragraph (1) or (2); or</li> <li>• 15 <i>business days</i>' of AEMO's notice of the impact described in sub-paragraph (3).</li> </ul>
(b) Where, in AEMO's reasonable opinion, information of the type described in clause S5.3a.1(a1) of the NER is required to enable an NSP to conduct a <i>system strength impact assessment</i> <sup>13</sup> .	Within 15 <i>business days</i> ' of AEMO's request to provide the relevant information.
(c) Before <i>connecting</i> any new or additional equipment to a <i>network</i> <sup>14</sup> .	With the <i>application to connect</i> submitted under clause 5.3.4 of the NER.

## 2.5 Prospective NSCAS Tenderers

The circumstances in which prospective *NSCAS* tenderers must provide models and other information to AEMO in respect of their *plant* or equipment under these Guidelines are specified in clause S5.5.7(b1)(1)(vi) [of the NER](#), namely when tendering to provide *NSCAS* under clause 3.11.5 of the NER<sup>15</sup>. The models and information must be provided to AEMO with an *NSCAS* expression of interest.

## 2.6 Prospective SRAS Providers

The circumstances in which prospective *SRAS Providers* must provide models and other information to AEMO in respect of their *plant* or equipment under these Guidelines are specified in clause S5.5.7(b1)(1)(vii) [of the NER](#), namely when tendering to provide *SRAS* under clause 3.11.9 of the NER<sup>16</sup>. The models and information must be provided to AEMO with a tender for the provision of *SRAS* or, where AEMO makes a direct request for an offer for the provision of *SRAS*, in response to that request.

## 3. MODELS AND DATA REQUIREMENTS

Changing *plant* technology in the *power system* has introduced the need for AEMO and NSPs to have a deeper understanding of all equipment *connecting* to the grid, including smaller *plant*, which in aggregate, can affect the *power system security* and *reliability*.

### 3.1 Generators, NSPs, Network Users, and MNSPs

On each occasion that a *Generator*, NSP, *Network User* or MNSP is required under the NER to provide models and other information to AEMO and an NSP<sup>17</sup>, they must provide:

- Completed *Power System Design Data Sheets* and *Power System Setting Data Sheets Data Sheets*;
- Site-specific RMS models of all *plant* that comply with these Guidelines, including:
  - model block diagrams; and
  - model source code;
- Site-specific EMT models of all *plant* that comply with these Guidelines;
- a RUG for both RMS and EMT models in the template specified in the Releasable User Guide Template<sup>18</sup>; and

<sup>12</sup> See clause 5.2.3A(a) of the NER.

<sup>13</sup> See clause 5.2.3A(b) of the NER.

<sup>14</sup> See clause S5.3a.1(a1) of the NER.

<sup>15</sup> See clause 3.11.5(b)(5) of the NER.

<sup>16</sup> See clause 3.11.9(g) of the NER.

<sup>17</sup> In the case of models and information required to be provided by an NSP, this is to be read as providing them to another NSP.

<sup>18</sup> Note that AEMO expects the Releasable User Guide Template to be *published* prior to the expiry of the consultation on this document.

- R2 test report, and pre-commissioning model confirmation test report<sup>19</sup>.

### 3.2 NSCAS Tenderers and SRAS Providers

On each occasion that a prospective NSCAS Tenderer or SRAS Provider is required to provide models and other information to AEMO, they must provide the models and other information specified in Section 3.1 except where they:

- had provided the necessary models and information to AEMO within the previous three years and AEMO had indicated at the time were acceptable;
- are not proposing to make any changes to the components of the *plant* or proposed *facility* within the intended period of any proposed agreement for the provision of *NSCAS* or *SRAS* (as applicable); and
- no changes are likely to occur to the operation of *plant* (regardless of whether they are owned by the relevant prospective NSCAS Tenderer or SRAS Provider) that will impact the proposed *NSCAS* or *SRAS* (as applicable) within the intended period of any proposed agreement for the provision of *NSCAS* or *SRAS* (as applicable),

AEMO will not require additional models and information, however, AEMO may require further clarifications on the models or information previously provided, in which case the relevant prospective NSCAS Tenderer or SRAS Provider will need to respond within any timeframe requested by AEMO at the time.

### 3.3 Exemptions

The requirements proposed in these Guidelines will apply for all *power system* conditions and model types, but there are circumstances where AEMO and an NSP may exempt an Applicant from having to provide the full complement of models and other information specified in Sections 3.1 or 3.2 (as applicable). Table 2 details the circumstances where AEMO and the NSPs may exempt an Applicant:

**Table 2 Grounds on which exemption may be granted**

Conditions	Reasoning	Item not required Exemption
<b>Plant size is ≤5 MVA and the connection point's aggregate SCR<sup>A</sup> &gt; 10</b>	Impact of the proposed <i>plant</i> on <i>network</i> and surrounding <i>plant</i> would be minimal. Proposed <i>plant</i> unlikely to be impacted by low system strength.	EMT model <u>not required</u> .
<b>Plant combined capacity size &lt; 1 MVA</b>	Impact of the proposed <i>plant</i> on <i>network</i> and surrounding <i>plant</i> would be insignificant.	No modelling information <u>required</u> .

A. As assessed by the *connecting* NSP accounting for all nearby *plant* that can reasonably impact SCR at the *connection point* under consideration.

Applicants whose *plant* meets the conditions specified in Table 2 need not apply to AEMO for exemption unless their *connecting* NSP requires them to do so. Hence, Applicants who consider that they should be exempt from having to provide the full complement of models and other information ~~should apply to~~ must approach their *connecting* NSP to seek advice on whether an application for exemption is required. If advised by the *connecting* NSP that it is, the Applicant must apply for exemption to AEMO and the relevant *connecting* NSP using the form contained in Appendix A.

Following consideration of an application for exemption, AEMO must:

- accept or reject it;
- propose options for the Applicant to consider; or
- request further information.

<sup>19</sup> Depending on the expected impact of the *plant* on the *power system*, pre-commissioning model confirmation results may be required before the *connection* can proceed.

## 4. MODEL AND STUDY TYPES

Section 4 provides a general introduction to the model and study types used by AEMO and NSPs for power system planning, operation and analysis.

### 6.0 Root mean square (RMS)

An RMS model provides a representation of the AC ‘phasor domain’ behaviour of *power system* elements in Steady State or in a simplified dynamic sense. *Voltage* and current variables are represented by complex numbers or their real components in rectangular or polar form. The magnitude of the complex number indicates the root-mean-square amplitude of a sinusoidal waveform (in a scale of units defined as part of the model) and the phase of the complex number indicates the phase angle lead or lag of the waveform from a fixed system phase reference. All waveforms are presumed to exist at the same fundamental frequency (50 Hz). Two types of RMS models exist. The first is the positive-sequence RMS model which represent one designated phase of a balanced three-phase system of the relevant phase sequence (positive, negative or zero). The second type is the three-phase RMS model where all three-phases, hence the resultant sequence components are accounted for. This would not, however, have any impacts on other general capabilities/limitations of the RMS-type models described below.

RMS models of *power system* elements are used to simulate *power system* behaviours during Steady State, Quasi-Steady State and Post-Contingent Steady State. They have been generally adequate for assessing most *power system* behaviours needed for planning and operating the *power system* securely and reliably in classical power systems with major centralised synchronous generators. However, for converter-connected devices RMS models can be inadequate. Additionally, due to their inherent limitations, the RMS models are not suitable for determining *power system* behaviours referred to as electromagnetic transient phenomena such as fast control-loop behaviour, fast transients associated with switching and lightning phenomena, or slow transients associated with sub-synchronous interactions, and control and harmonic interaction.

#### 9.0.0 Load flow

The load flow model is a Steady State RMS model of the *network*, with *connected plant* represented by their Steady State power input/output and/or *voltage* characteristics. It may be likened to a single-line diagram that specifies the circuit layout and quantifies all *network elements* by means of the series AC impedance of branches, the shunt AC admittance *connected at busbars* (all at fundamental frequency), and *transformer ratios*.

The load flow model will also usually include the specification of *network* control equipment (such as transformer tapping) that responds automatically to the Steady State conditions in the *network* by automatically adjusting the *transformer ratios*, impedances or admittances of *network* equipment (including the limitations to such adjustments). When the load flow model has been solved to the point where all such adjustments have concluded and no further adjustments take place, as the model is in a settled Steady State. Conversely, a *network* load flow solution where the fast-acting *plant* controls are presumed to have operated but the slower-acting *network* controls are yet to respond is a Post-Contingent Steady State (also sometimes known as a ‘transient’ or ‘dynamic’ steady state)<sup>20</sup>.

Depending on the application, the load flow model may include impedance and *plant* model data for the positive sequence only, or for all three phase sequences. The positive sequence model is generally adequate to represent the Steady State of the *power system* in normal operation or following a symmetrical Disturbance such as a three-phase fault. The complete three-phase model accounting for sequence components is required when the prospective Steady State response is sought to an

<sup>20</sup> Clause 4.2 of the NER uses the terms *secure operating state* and *satisfactory operating state*, but the *power system* can also be described by reference to Steady States. In essence, the *satisfactory operating states* are the stable Steady States of the *power system* where relevant quantities remain within their normal operational limits, while the *secure operating states* are a subset of these states such that the occurrence of any *credible contingency event* eventually leads to another *satisfactory operating state*. The terms Steady State and Post-Contingent Steady State overlap but do not correspond one-to-one with the NER-defined terms: it is possible for a Post-Contingent Steady State to represent a *secure operating state*; conversely, it is possible for a Steady State to represent a *satisfactory operating state* but not a *secure operating state*. Usually, a Steady State will at least satisfy the criteria for a *satisfactory operating state*.

asymmetric disturbance or an unbalanced three-phase *plant*, or when the effect of *network* asymmetries is to be studied.

### 13.0.0 Fault level

Fault level studies are Quasi-Steady State type analyses, where models supplied for these studies are required to represent their *plant's* contribution to short-circuit current when a *network element* is in a faulted state.

Static models based on Thévenin equivalent representation have been traditionally used for calculating short-circuit current contribution of *synchronous generation* (representing constant rotor flux), and this approach remains valid. A similar approach has sometimes been applied to converter *connected generation*<sup>24</sup> to develop an equivalent fault study representation of a wind farm or large-scale solar photovoltaic *generating systems*. More specifically, equivalent source impedances and time constants are estimated for the converter-connected *generation*.

The main disadvantage of this approach is the reduced accuracy of results when this methodology is applied to remote faults. To develop more detailed models of converter *connected generation* for fault level studies, it is necessary to appreciate the key difference between the performance of conventional *synchronous* machines and converter *connected generation* technologies, which is the active control of the converter during fault conditions.

Specifically, transients caused by converter components during a fault are not generally accounted for in the Thévenin equivalent representation. This includes the action of crowbars or dynamic braking choppers. The sequence of actions taken by the fault ride-through control of the converter results in a different response at different instances during the fault and after fault clearance. Additionally, state-of-the-art control of power electronic converters allow for separate control of positive and negative sequence components of the fault current. Design variations exist covering intentional negative-sequence injection to full cancellation.

For these nonlinear *power system* elements, including power electronic converters, the three-sequence representation is generally inadequate. Short-circuit response of such elements is studied using full dynamic simulations, or by linear approximation of the terminal *voltage-current* relationships for each phase sequence to obtain Thévenin or Norton equivalent models. The IEC60909:2016 standard provides formulae for Thévenin and Norton equivalent source components for direct connected induction machines, doubly- and fully-fed induction generator-based wind turbines and other types of power electronic converters in cases where an approximate linear short-circuit model is required.

### 19.0.0 Transient stability

For RMS models, dynamic modelling of *power system plant* for time-domain simulation is made possible by exploiting the mathematical equivalence between the Steady State AC phasor representation of three-phase quantities, and the instantaneous representation of these quantities (ignoring any zero-sequence component).

Time-domain studies are used extensively to assess detailed stability performance in response to Disturbances and set-point changes. In practice they are generally one of the following types<sup>22</sup>:

- **No Disturbance or set-point change studies (flat runs).** These commence from a Steady State of the *power system* and involve running the time-domain simulation for a period without applying any Disturbance or set-point change. As the initial condition is a Steady State, it is expected that *power system* quantities associated with the *plant* model will not change appreciably during the simulation. Simulation durations for no-Disturbance studies range from 10 to 300 seconds (the latter to verify long-term Steady State stability).
- **Single Disturbance or set-point change studies.** These commence from a Steady State of the *power system* and involve applying a single Disturbance or set-point change during the simulation. If the Disturbance is a fault, the simulated Disturbance includes the appropriate short-term

<sup>24</sup> Including wind turbines based on type 3 and 4, and solar inverters.

<sup>22</sup> Note the list of studies here is not an exhaustive, and models may be used by AEMO and the NSP for other purposes not stated here.

protection action to clear the fault. The simulation is then run long enough to establish the Post-Contingent Steady State. For RMS models, the Disturbance or set-point change will typically be applied at least one second into the simulation to allow for decay of any short-term numerical transients. For EMT models where the Steady State must be established during the initial run of the simulation, the pre-Disturbance or set-point change time will be correspondingly longer. Overall simulation durations for single Disturbance studies range from 5 to 120 seconds following application of the Disturbance or set-point change.

- **Multiple Disturbance or set-point change studies.** These operate similarly to single Disturbance or set-point change studies but involve applying a defined sequence of Disturbances or set-point changes at specific times from the initial Steady State. These will typically involve a succession of Post-Contingent Steady States in between the applied Disturbances or set-point changes. An example of a multiple Disturbance or set-point change study is a reclose study, where an initial fault cleared by protection operation leads to an auto-reclose event after a predefined period. Studies may also be carried out to simulate multiple *contingency events*.

Depending on the overall duration, multiple Disturbance or set-point change studies may also require time-domain modelling of medium and long-term controls.

The specific applied Disturbances or set-point changes, monitored quantities and performance criteria for the study will depend on their purpose.

An RMS model for dynamic simulation is inherently limited by the fact that the *network* itself retains its Quasi-Steady State phasor representation. It is therefore limited to representing the fundamental-*frequency* behaviour of *network* quantities, and excludes the dynamics associated with *network elements* themselves (also known as ‘network transients’). These limitations are usually not material for conventional transient stability studies where the critical *power system* responses occur on timescales longer than an AC cycle. However, very short-term, sub-transient phenomena in either the *network* or *connected plant*, with response times shorter than an AC cycle, cannot be adequately represented with an RMS model, and phenomena exhibited by RMS models on such short timescales are not necessarily reflective of real-world behaviour.

### Mid- and long-term dynamics

Previously, equipment and control systems that operated within longer timeframes (several tens of seconds) have been omitted from generator and power system models as they introduced additional computational burden for events that were unlikely to occur during the short transient simulations<sup>23</sup>.

Experience gained during commissioning and R2 testing has shown that inclusion of the transformer tap changer, park controller, shunt device etc. models can have a significant impact on meeting model accuracy requirements. Additionally, experience gained from simulating large-scale *network frequency* disturbances and comparison against respective measured responses has demonstrated inaccuracy of turbine-governor models in simulating events lasting several seconds.

Hence, dynamic models covering phenomena with a dynamic response time of up to two minutes or longer are necessary whenever they can have a material impact on the dynamic response of the *plant*, and thereby on meeting model accuracy requirements. Any dynamic models provided by a *plant* must be adequate for simulation of the response of equipment, such as on-load tap changer controllers, turbine governors, over-excitation or stator current limiters and any other thermal, voltage or frequency related controller with a time-delayed response.

## 32.0 — Electromagnetic transient (EMT)

### 33.0.0 — Transient stability

As large amounts of *asynchronous plant* are introduced into the *power system*, it is increasingly critical that EMT models are utilised to cover inadequacies of RMS models when performing standard *power*

<sup>23</sup> Currently, computing technology allows the inclusion of these components with minimal impact on simulation time.

system stability assessments. This includes due diligence on new or modified *generating systems*, and *power system security* assessments.

An EMT model provides a full time-domain representation of a *power system* based on a level of detail that can accurately represent the kHz range switching algorithms of semiconducting switching devices and fast *control systems* in power electronic converters. Unlike in a RMS model, the *network* is represented as individual phase *voltages* and currents in the time domain linked by differential equations. Because of this, the EMT model can represent both the detail of sub-cycle controls, and the phase-by-phase response to unbalanced Disturbances.

In addition to traditional fast-transient analysis, EMT modelling is often required when studying the effect of fast-acting controls under low system strength conditions, where the local AC *voltage* amplitudes and phase displacements have a higher sensitivity to small changes in power flows associated with dynamic *plant*. For example, power electronic converters often rely on a fast-acting phase locked loop (**PLL**) to maintain *synchronism* between its injected current and local *network voltage*, and studying the stability of this PLL response often requires EMT simulations, as RMS models are inherently unable to represent such key components. Other control loops such as DC link current and *voltage* controllers can exhibit similar inaccuracies. Without representation of such components, RMS models of *asynchronous plant* may fail to show instability that would occur and, hence, would provide inaccurate conclusions. As these types of dynamic studies feed into operational decisions, this could increase the risk of the *power system* being operated insecurely.

The use of EMT-type models for *power system* dynamic analysis assists in determining confidence in the conclusions made by RMS-type models as traditionally used for large-scale *power system* studies, or to replace them completely when RMS-type models fail to predict the phenomena of interest accurately. This allows for accurate and adequate methods to manage the impact of new, modified or existing *generation* and other *power system plant* on *power system security* and *network* transfer capability.

AEMO and NSPs use PSCAD™/EMTDC™ to perform EMT studies in the NEM.

### 39.0.0 Switching and lightning

The dominant *frequency* at which overvoltages manifest can range from several hundred Hz to several hundred kHz. Overvoltage events can, therefore, be classified as follows, based on the dominant *frequency* of the phenomenon:

#### Temporary overvoltages (TOVs)

These are relatively low *frequency* (below 3 kHz) short duration overvoltages. Since the duration of such overvoltages can be over several cycles, they can place a burden on surge arrester energy dissipation. System grounding practice employed will play a role in determining the severity of TOVs. The TOV study will identify overvoltages that may excessively stress the equipment insulation or the surge arrester energy duty.

Some events that can trigger TOVs are:

- Asymmetrical faults.
- Load rejection.
- Transformer saturation interaction.
- Harmonic resonance and Ferro-resonance events.
- Loss of grounding reference.
- RMS models can be used to provide early indication of temporary overvoltages, however, these types of models are generally unable to accurately represent TOVs with a magnitude greater than 1.15-1.2 pu, necessitating the use of EMT models for simulating these types of TOV. Additionally, modelling *transformer* saturation interaction, harmonic resonances and Ferro-resonance issues requires the use of EMT modelling. In general, models provided by Applicants must be sufficiently accurate for assessing TOVs.



## Transient overvoltages

- Switching of system elements such as cables, lines, and capacitor banks, can create transient overvoltages and very fast *voltage/current* changes. The *power system* studies must investigate the switching events that are likely to induce the maximum stress on the electrical components. The results from switching studies are used for:
  - insulation co-ordination to determine overvoltages stresses on equipment.
  - determining the arrester characteristics.
  - determining the transient recovery *voltage* across *circuit breakers*.
  - determining the effectiveness of transient mitigating devices, e.g., pre-insertion resistors, inductors and controlled closing devices.
- These studies are also exclusively conducted with EMT-model but due to high-*frequency* nature of the phenomenon of interest, the level of modelling details required is generally different to those required for stability studies with EMT-type models.

## Other fast overvoltages

- These types of overvoltage are generally in the range of several tens of kHz to a few MHz. Typical phenomena of interest include lightning strikes and very fast front overvoltages due to the interaction of *circuit breakers* with nearby *power system* components. These studies are also exclusively conducted with EMT-models but due to the very high-*frequency* nature of the phenomenon of interest, the level of modelling details is generally different to those required for stability studies with EMT-type models.

### 59.0.0 Sub-synchronous interaction

Sub-synchronous interaction (**SSI**) refers to adverse interaction between two or more electrical or electromechanical *power system* components often with a dominant *frequency* of less than the nominal power system frequency but significantly higher than the range associated with local and inter-area modes of oscillations. For this reason, neither RMS-type, nor small-signal stability simulation tools can be used. The use of EMT-type modelling is therefore necessary.

SSI can be generally divided into:

- Sub-synchronous torsional interaction (**SSTI**) is an electromechanical interaction between a power electronic connected component such as HVDC and FACTS devices, and the rotating masses of the turbine-generator in conventional *synchronous* machines.
- Sub-synchronous control interaction (**SSCI**) is a purely electrical interaction between a power electronic component and a series compensated AC line. Compared to the SSTI, SSCI is a faster developing phenomenon due to the fast action of the converter control.
- Sub-synchronous resonance (**SSR**) is an electromechanical interaction between a series compensated AC line and the rotating masses of the turbine-generator.

### 65.0 Small-signal stability

Linearised small-signal models of the *power system* are used to assess the adequacy of damping of oscillatory modes that are present in normal operation. The dynamic models of *connected plant* are linearised around specified operating points, and the resulting linear models are assembled by way of the linear *network* equations into a full state-space model of the *power system*. The eigenvalues of the state transition matrix for this full model define the *frequency* and damping of each system mode.

Operating point dependent linearised small-signal models are currently derived by NSPs and AEMO from model information supplied for RMS-type dynamic models. Hence, the quality of small-signal models is directly dependent on the quality of the large-signal RMS dynamic models and data.

## 68.0 — Power quality

The NSPs conduct power quality analysis to assess whether their *transmission networks or distribution networks* are operated within the *system standards* as set out in clauses S5.1a.5, S5.1a.6 and S5.1a.7 of the NER. *Connection Applicants* must also conduct power quality analysis to demonstrate whether they can meet their proposed *performance standards* under clauses S5.2.5.2 and S5.2.5.6 of the NER, and to investigate power quality issues associated with their *facilities* and potential mitigation of any issues.

EMT time domain models and simulations may be required for assessment of harmonic susceptibility, including de-stabilization of *network* operation due to harmonics.

### 71.0.0 — Harmonic emission

This type of analysis is generally performed with commonly used harmonic analysis tools, which are Quasi-Steady State simulation tools. However, EMT-type models may be occasionally used to allow for more accurate representation of the harmonic performance of power electronic connected devices in time domain, especially under low system strength conditions.

Current electricity industry practice when carrying out harmonic emissions analysis is to consider harmonic-generating devices as ideal harmonic current sources. Here, a Norton or Thévenin representation is necessary when assessing compliance with *performance standards*, and determining the contribution of the *generating system* and other harmonic *generating plant* to the *network* harmonic distortion levels.

The current injected by an ideal current source does not change with system impedance or due to the presence of other harmonic sources, such as grid background *voltage* distortion. When analysing the influence of other sources, the harmonic source modelled in this way would be considered as an open circuit. In practice, harmonics generated by the *voltage* source converters used in *asynchronous plant* do not remain constant but vary according to the grid conditions, *generation* operating conditions, and the converter control action.

*Asynchronous plant* can still be characterised by a Norton or Thévenin equivalent source, however, to realise such a representation there is a need for dedicated harmonic models accounting for *frequency* dependency of harmonic impedance rather than providing harmonic current injection profiles only. This is because for *asynchronous plant*, the observed *connection point voltage* and current harmonics are grid dependent, while also depending on the grid background harmonics. More specifically, some harmonics are generated by the power electronic converter, whereas others are due to grid background harmonics, and therefore seen at the *connection point*. Therefore, power electronic interfaced technologies can only be represented as an ideal current source if the change of terminal *voltage* or the *voltage* imbalance present in the external *network* does not change the “harmonic profile” of the device.

The existing practices for modelling *synchronous plant* for harmonic studies are generally adequate and appropriate.

### 77.0.0 — Harmonic susceptibility

When considering *plant* harmonic susceptibility, the level of Steady State harmonic distortion is not the main point of interest. The primary interest is the potential de-stabilization of the operation of *plant*, *network* components, or excitation of a system resonant *frequency*. Investigation of harmonic susceptibility issues cannot be generally dealt with conventional harmonic penetration analyses, and needs more advanced analysis techniques such as time domain based EMT simulation models and methods.

Figure 2 illustrates the *frequency* domain of different harmonic phenomena. This figure indicates that the dominant frequency of power system harmonic phenomena can range from a few Hz to several kHz often associated with pulse width modulation (PWM) in voltage source converters.

**Figure 80 Frequency domain of different harmonic phenomena**

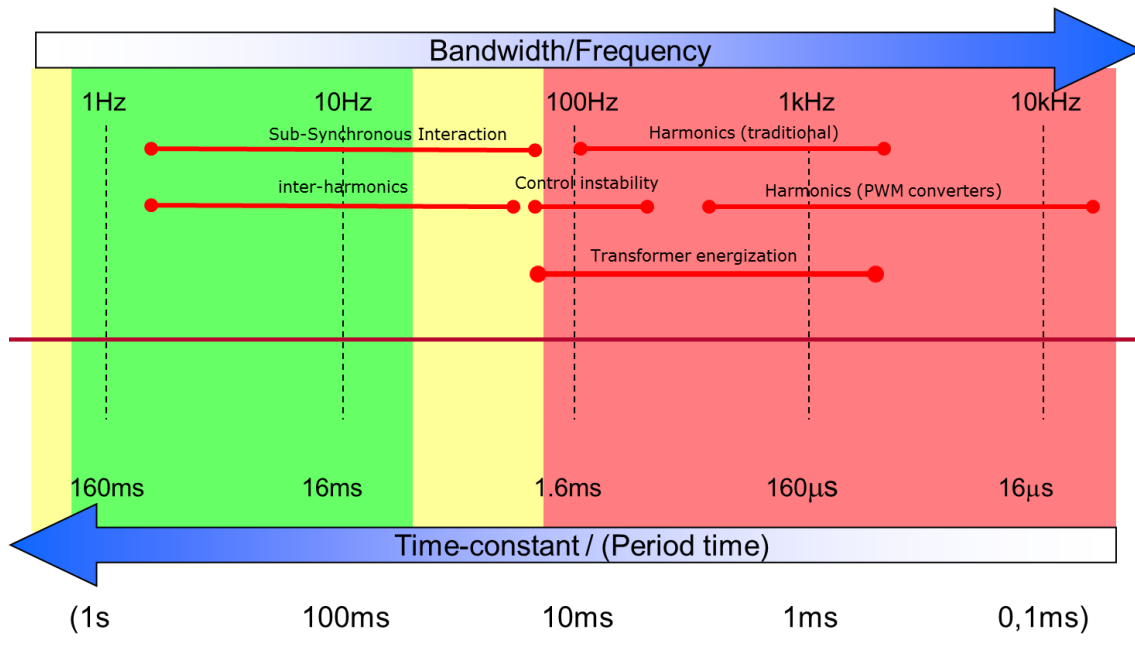

Examples include:

- Investigation of the possibility of power electronic converters exciting a *network* resonance point, or switching studies of *transformer* and *reactive power support plant* including harmonic filters.
- Adverse interaction of multiple power electronic interfaced devices with similar bandwidth due to the injection of integer or non-integer harmonic current components. These studies are better classified as specialised EMT-type studies.

### 85.0.0 Flicker

Flicker, also known as *voltage* fluctuations, can be a result of:

- Loads drawing currents having significant sudden or periodic variations (i.e. Arc furnaces, Arc welders, frequent motor starts, motor drives with cyclic operation, equipment with excessive motor speed changes)
- Generation from renewable resources (i.e. cloud coverage, wind variations)
- Switching of *network* equipment (i.e. switching of shunt capacitor, shunt reactor, energisation of *transformer*)
- Interaction between different control devices (i.e. SVC interacts with a nearby power electronics devices)
- Control system on FACTS that deliberately causes *voltage* variations (i.e. power oscillation damper (POD) on SVC)

Depending on the nature of the *voltage* fluctuations (underlining mechanism and the oscillating *frequency*), RMS or EMT models and simulations may be required.

### 93.0.0 Voltage unbalance

Three processes can contribute to the negative-sequence voltage at a bus:

- Contribution from the background *network* 50 Hz negative-sequence *voltage* at this location;
- Steady State 50 Hz negative-sequence currents injections, from the devices connected at this bus, into the 50 Hz negative-sequence source impedance produce a contribution to the negative-sequence *voltage* at this location; and

- Steady State 50 Hz positive-sequence currents injections, from the devices connected at this bus, produce a contribution to the negative-sequence voltage at this location due to the phase-impedance asymmetry of the three-phase ac power system.

Voltage unbalance assessment can be carried out using suitable conventional power quality analysis tools, or EMT models and simulations.

### 99.0 Summary

The following table is a summary of the previous discussion and sets out the model type as a function of study type.

**Table 101— Summary of model vs. study appropriateness**

Model type \ Study type	RMS	EMT	Harmonic	Fault level	Small-signal
Load flow	✓				
Fault level				✓	
Transient stability	✓	✓			
Small-signal stability					✓
Power quality		✓	✓		
Switching <sup>24</sup> and lightning		✓			
Sub-synchronous interaction <sup>5</sup>		✓			

A. Three-phase RMS representation.  
 B. Including black start studies.  
 C. Including sub-synchronous control and torsional interactions.

## 163.4. MODEL ADEQUACY

Section 5 outlines AEMO and NSP requirements for models, depending on the study being conducted.

### 163.1 Model adequacy as function of phenomena of interest

There are broadly two dimensions that make a model adequate for a study:

- the type of simulation tool used to perform the assessment, e.g. RMS or EMT-type simulation; and
- the components and functionality of the plant included in the model.

The type of study being undertaken, the type of primary and secondary plant, and the phenomena of concern will all determine the adequacy requirements.

Figure 3 shows the relationship between simulation types, bandwidth<sup>24</sup> required, and examples of the phenomena being analysed. Some phenomena can only be analysed when the underlying tool can represent it. Figure 3 shows that for an EMT-type model to be adequate it would need to account for components such as fast-acting converter controls including the PLL that cannot be represented in a RMS-type simulation.

<sup>24</sup> Bandwidth is used to encapsulate phenomena that may span multiple frequencies as part of its response. A 10 kHz bandwidth will require a period of  $1/(2 \cdot \pi \cdot f_0) = 16 \mu\text{s}$ .

**Figure 2 — Model types versus bandwidth**

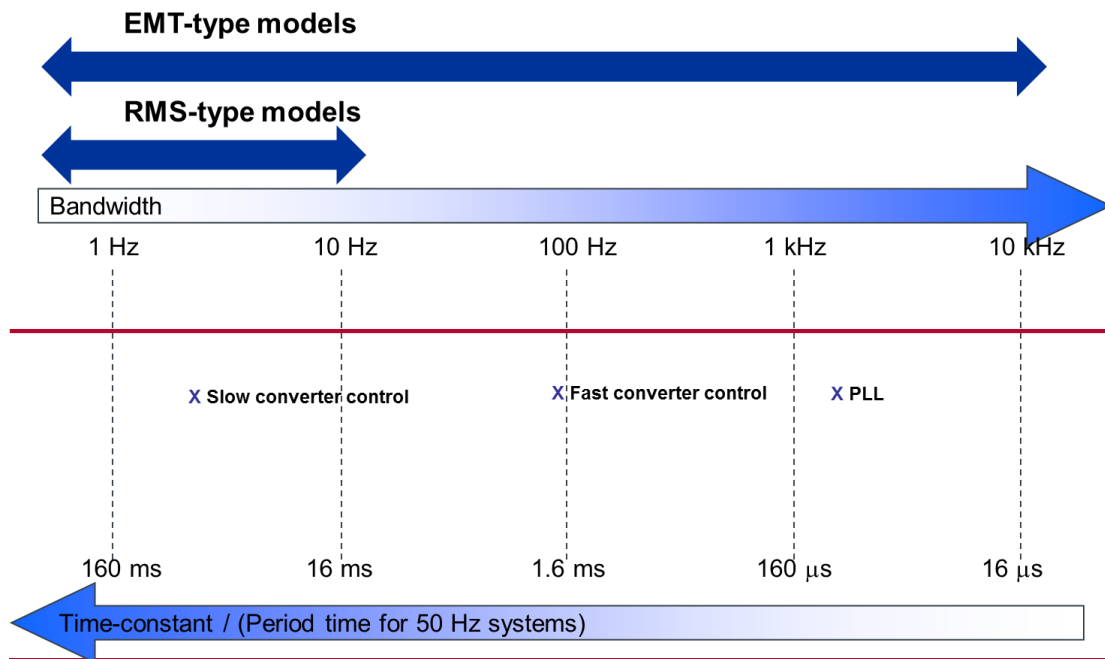

[AEMO and NSPs use \*plant\* models for many purposes. The assessment of the suitability of proposed \*plant\* and its proposed \*performance standards\* and determination of \*plant\* capability to achieve its \*performance standards\* are the ones that most \*Registered Participants\* are aware of, and is the main reason why they must provide models, but this is just one of many. Others include the ongoing management and assessment of \*power system security\*, such as short-term operational planning and development of \*constraint\* equations, stability assessment, use in long-term \*power system\* planning, the assessment of other proposed \*connections\*, procurement of \*ancillary services\*, simulations for the purpose of training and incident investigations.](#)

[For these reasons, models must demonstrate the degree of adequacy and accuracy specified in these \*Guidelines\*.](#)

For each *plant* being assessed, the Applicant must provide a site-specific model in the appropriate tool and consisting of components necessary to facilitate accurate studies for the specific phenomenon under consideration.

[Subject to any requirements specified elsewhere in these \*Guidelines\*, it is expected that models provided to AEMO and the NSPs are an accurate representation of \*plant\* and \*plant\* responses for multiple, successive Disturbances. This does not require those providing models to consider every conceivable combination of Disturbances. For example, when submitting models for the purpose of \*connection\* studies, the submitting party can evaluate responses to singular or limited combinations of Disturbances only to the extent that they are relevant to the \*access standard\* being considered.](#)

### 163.1.1 Further details

Appendix C outlines the physical components to be included in a model based on the studies being performed. As load flow and fault level studies are typically based on Newtonian solution methods, rather than physical components, these study types are excluded from the tables in Appendix C.

Due to the continuous evolution of technology, the tables in Appendix C may not cover every key component present in all *plant*. If a *plant* or component not specified in those tables is determined by AEMO and the NSP to provide a significant contribution to the result of a study, AEMO and the NSP may request that this *plant* or component be included in the model submitted by the Applicant.

### 463.24.1 Load flow model requirements

Adequate load flow models must represent the *plant* Steady State conditions for the full operating envelope in the software package nominated by AEMO and the NSP.

Where applicable and where the RMS tool allows, load flow models of *plant* must include:

**Table 3 Load flow model inclusions**

Plant element	Including
<b>Generating units<sup>A</sup>, reactive support <i>plant</i></b>	MVA base
	Source impedance, including positive, negative and zero sequence
	Active and reactive power profile <sup>B</sup>
	Voltage control scheme
<b>Plant transformers<sup>A</sup> (including step-up, intermediate and connection point)</b>	MVA base and ratings
	Winding vector group
	All winding voltages
	Winding impedances, including positive, negative and zero sequence
	Grounding arrangements and impedances
	Connection code
	Magnetising impedances
	Tap location, number and voltage range
	Voltage control scheme
<b>HVDC links</b>	Plant ratings, voltages and impedances
	Control modes, including target control quantities
	Base voltages levels and target voltage levels
	Transformer impedances, voltages, tap ranges, bases
	Firing angle ranges (for applicable technologies)
	Commutating impedances (for applicable technologies)
<b>Reticulation network<sup>A</sup></b>	Positive, negative and zero sequence impedance
<b>Shunt components</b>	Switched shunts
	Fixed shunts
	Switched shunt voltage control scheme
<b>Loads</b>	Active and reactive power levels, in most appropriate format (power / impedance / current)

A. For plant consisting of several distributed generating units, aggregation principles outlined in Section 4.7 must be used.

B. Consistent with the plant's performance standard

The load flow model contents must be consistent with the information provided by the Applicant in the RUG.

#### 463.2.14.1.1 Format

Section 4.3.9 outlines the model format requirements for load flow models when represented in RMS simulation tools.

### 463.34.2 Fault level model requirements

Provision of short circuit data for the *plant* to IEC 60909:2016 is sufficient to meet the requirement for short circuit analysis. This short circuit data should be integrated into the load flow model to the extent this is possible in the host software platform.

#### 463.3.14.2.1 Format

Section 4.3.9 outlines the model format requirements for fault level models when represented in RMS simulation tools.

### 163.44.3 RMS and EMT stability model requirements

The following criteria apply before an RMS or EMT model can be accepted for assessment by AEMO and the NSP. [The requirements specified in this section apply to all \*plant\* except those in section 4.3.2, which only apply to \*plant\* participating in the FCAS market or the provision of other forms of frequency control, such as in a future fast frequency response market.](#)

#### 163.4.14.3.1 General requirements

Transient models provided under clause S5.2.4(b) of the NER must define the site-specific electromechanical and *control system* performance of components comprising *plant* under Steady State, set-point change and Disturbance conditions for all levels of system strength and energy source availability that the *plant* is rated to operate.

That *plant* includes:

- the *generating unit* or any other primary or relevant secondary *plant* within the *generating system* that may affect the overall interaction (*active power, reactive power or voltage*) of the *generating system* with the *power system* (e.g. *reactive power compensating plant*).
- any dynamic *reactive power or voltage* compensation *plant* within the *network* that can have an impact on transient and *voltage* stability.

Parameters of transient models developed for new and modified *generation connections* (including any supervisory control) should be refined through extensive connection studies. *Plant* model and parameters must be assessed through the NSP and AEMO due diligence process to be qualified as R1 data.

RMS and EMT models and parameters submitted to AEMO and the NSP must conform to the following general requirements before being considered for assessment.

#### Model compatibility and stability

Models must:

- be compatible with the *power system* software simulation products specified by AEMO and the NSP;
- work for a range of dynamic simulation solution parameters rather than for specific settings only;
- be numerically stable for the full operating range including a wide range of grid SCR and grid and fault X/R ratio;
  - any model validity limitations due to system impedance or strength should be clearly defined within the RUG;
- be numerically stable up to a simulation time of [up to five minutes<sup>25</sup>](#) (have *voltage, frequency, active power* and *reactive power* remaining constant for dynamic simulation runs with no Disturbance);
- not show characteristics that are not present in the actual *plant* response;

#### Model composition and operating range

Models must:

- be a model of the specific *plant* being considered;
- include any relevant non-linearities, such as limits, arithmetic or mathematical functions, deadbands or saturation, etc.
- represent the *generating system* and reactive compensation *plant* performance for all possible Steady State output and system strength levels where the plant would be in operation;
- represent *plant* response for set-point changes including *active power, reactive power, power factor, voltage* and *frequency*, including associated *ramp rates*.

<sup>25</sup> [RMS models must meet the five-minute requirement. EMT models need only be numerically stable for up to two minutes. The model user should wait for the model to initialise and then run it for stability.](#)

- represent the *generating system* and reactive compensation *plant* performance for all possible values of energy source variation where the *generating unit* or *generating system* would be in operation;
  - For *generating units* with an inherently variable power source, the ability to vary the energy source strength must be maintained throughout the simulation study;
- represent all *plant* within the *generating system*, including *generating units*, governors, park controllers, *tap-changing transformers*, and *reactive power* compensating *plant*;
  - Relevant protection relays must be included in the model, explicitly where practically possible.
- Represent delays between *plant* elements (e.g. SCADA, PLC and park controller communication delays) that have an impact on the performance of the *plant*;
- include models of *generating unit* mechanical components that would be affected by Disturbances;
- include models of *generating unit* energy storage components that would be affected by Disturbances;
- represent *plant* response to any runback scheme or special protection scheme in which the *plant* participates in;
- represent *plant* performance accurately within the normal dispatch range between minimum and maximum active power output, but must also be able to be initialised at any *active power dispatch* down to 0 MW;
  - Linearised models that are valid only for a single operating point are not acceptable; and
- can be initialised correctly (for example, for RMS models from load flow) if dispatched to a power level lower than that available from the fuel source.

### Model multiple operating modes and control functions

A model must:

- represent all modes of operation that the physical plant is capable of operating in. For example, if applicable to the physical *plant*, the model must be able to represent:
  - *generation*, *synchronous condenser* and pump modes for relevant hydro-electric generation technologies, e.g. pumped storage.
  - *voltage* control, *power factor* control and *reactive power* control modes.
  - activation/deactivation of *frequency* control and fast frequency response features.

All changes to operating modes should happen automatically. Where automatic mode switchover cannot occur, operating mode changes must be based on configuration file or variable changes. It is not acceptable to require a separate model for each operating mode.

- represent the simultaneous control functions that are active within the physical *plant* without the need to change model setup, variables or configuration parameters.
  - For example, a model must be able to represent both *active power* control and *frequency* control functions operating simultaneously.

### Mid- and long-term dynamics

Any dynamic models provided for a *plant* must be adequate for simulation of the response of equipment, such as onload tap changer controllers, turbine governors, over-excitation or stator current limiters and any other thermal, *voltage* or *frequency* related controller with a time-delayed response up to 120 seconds.



Additionally, models must not change appreciably<sup>26</sup> during a flat-run (no Disturbance) simulation. Simulation durations for no-Disturbance studies range from 10 to 300 seconds (the latter to verify long-term Steady State stability).

#### 163-4.24.3.2 Additional requirements for frequency stability studies

For *frequency* stability studies, models must also:

- provide an accurate response of the *plant* to changes in *network frequency*, and *active power generated* to the *network*, regardless of whether it is enabled as FCAS.
- take into account both central controllers and distributed plant if an aggregated service is used to provide FCAS.
- be an accurate representation of the maximum rate of change of *frequencies* that the plant is capable of operating with;
  - for absolute changes in network frequency within the *frequency operating standard* where the *plant* is connected. If the *performance standards* of the *plant* exceed these limits, the models must be accurate for the full range of *network frequency* in which the *plant* can operate;
- represent the *frequency* and speed filtering applied in the governor system controller and/or time delays in control variable measurement transducers;
- represent any controller settable control variable position limits, ramp rate limits or deadbands;
- include any mechanical actuator limits e.g. fuel valve open/close rate of change limits, pitch limits, open/close position limits, exhaust temperature limits, internal turbine limits, active power limits or other physical limits within the *control system* that cause a limit on power output and/or fuel flow;
- include fuel valves and fuel valve actuators that have control dynamics in addition to the *control system*, where these can affect the stability of the governing system or have an appreciable effect of the accuracy of the model must be included in the model;
- include non-linear fuel flow to valve position and/or non-linear fuel flow to power characteristics, where an efficiency characteristic has an appreciable effect of the accuracy of the model;
- include large Disturbance controls, such as intercept valve control on steam turbines, load rejection detection, acceleration control, power load unbalance detection and pre-emptive overspeed detection.
- include external (to the governor/power *control system*) control action (e.g. from *Generator SCADA* system), to regulate the power set-point during *frequency* Disturbances when enabled and not enabled for FCAS.
- include control mode changes or control gain changes that may be triggered from *network* Disturbances (for example, in the case of islanding situations where the *network frequency* may vary within the normal contingency bands, or where special logic is used to boost FCAS capability);
- represent any automated deployment of FCAS (specifically fast raise/lower and slow raise/lower service) where this is provided in addition to (or when *generation* has been *dispatched* for a specified FCAS amount) or by normal governor action with additional algorithms or controls. Where other control logic is used (e.g. SCADA/AGC) to deploy the FCAS by direct control of the power set-point during a *frequency* Disturbance this must also be included in the model.
- represent the fuel delivery system dynamics where this has a material influence on the power output during and after a *frequency* Disturbance and within a timeframe up to five minutes from the initiating Disturbance, or where the fuel delivery system is common to multiple *generating units* or derived from the *generation* in other units within a *plant* such that changes in *active power*

<sup>26</sup> State changes in RMS models or noise/chatter in both RMS and EMT models are not expected to occur for flat-runs.

*generation* on one *generating unit* can cause a change on another *generating unit*. Some examples of these are:

- Hydro *generating units* being supplied from a common penstock/surge tank.
- Combined cycle *plant* where a heat recovery system from gas turbines is used to generate steam for a steam *generating unit*.
- Gas turbines where the turbine mechanical power decreases with *frequency*.

### 163.4.34.3.3 RMS model-specific requirements

The following are requirements for RMS dynamic models supplied to AEMO and the NSP:

- models must have a bandwidth of at least 0.05 Hz to 10 Hz (for that part of the response that is linear) and settle to the correct final value for the applicable *power system* conditions and applied Disturbance(s);
- models must initialise themselves in a Steady State consistent with the system conditions in the network load flow model. When these preconfigured system conditions are beyond plant operational limits or otherwise not consistent with valid operating conditions for the plant, the model must warn the user by way of a message to the progress output device;
- where special tuning of the load flow case is required to replicate expected operating conditions with given control set-points, acceptability of the tuning procedure must be agreed to by AEMO and the NSP and documented in the RUG. Where a script is provided to assist with this procedure, it must be provided in the Python language;
- changes to the Steady State operating point for the modelled element must not require changes to any external dynamic settings (for example, in PSS@E, CONs, and ICONs) except where the change cannot be adequately inferred from the network load flow case. Where the Steady State configuration of the model cannot be uniquely inferred from load flow (e.g. Steady State wind speed when operating a wind turbine at 100% output), additional configuration parameters may be provided in runtime settable variables. Reasonable default values must be provided or inferred for any such parameters;
- when initialised at a valid Steady State operating point for the plant within operational limits, the model must correctly calculate state derivatives (for example, in PSS@E, models must not cause 'INITIAL CONDITIONS SUSPECT' messages at simulation start). This will generally be the case when the derivative calculated for each state variable is no greater than 0.00001<sup>27</sup>, or 0.01 times the initial value of the state variable (whichever is greater), in absolute value at time of initialisation;
- to avoid excessive simulation burden when integrating RMS models into OPDMS and DSA tools the minimum permissible values of the numerical integration time step and acceleration factors are 1 ms and 0.2, respectively. ~~The RMS model must not attempt to implement dynamic functionality with an intrinsic time constant shorter than 5 ms. Where this is necessary to achieve an adequate performance, a simplified numerical integration algorithm may be implemented within the model subroutine itself;~~
- models must be compatible with dynamic simulation frequency dependency functions that the tool provides (for example, the Network Frequency Dependence option in PSS@E);
- **RMS** model outputs in terms of the voltage, frequency, active power and reactive power must be reasonably constant and consistent when doubling and halving the recommended time step;
- models must be rigorously tested within a NEM-wide simulation for integration compatibility for large-scale *power system* studies. Experience has shown that SMIB simulations do not always reveal new models' adverse interactions with other models in the system; and

<sup>27</sup> PSS@E considers any state variable initialised with an absolute value less than 0.001 to be 'practically zero' and compares the calculated rate of change with the fixed threshold 0.01 for such variables. Otherwise, the ratio of the rate of change to the initial value is compared with the 0.01 threshold. In the worst case, an initial state equal to 0.001 will trigger a 'suspect' initial condition if its rate of change exceeds 0.00001.

- models must not write messages to the console during a simulation run other than in response to error conditions to signal abnormal events (such as a protection trip) or when additional model-specific output has been requested by the user.

#### 163.4.44.3.4 EMT model-specific requirements

The following are requirements for EMT dynamic models supplied to AEMO and the NSP<sup>28</sup>:

- have a bandwidth of at least DC to 10 kHz and settle to the correct final value for the applicable *power system* conditions and applied Disturbance(s);
- be based on *plant* design data and rigorously tested against factory acceptance tests for the corresponding version of *plant*;
- include detailed representation of all inner and outer control loops for the *plant*<sup>29</sup>;
- represent all electrical, mechanical and control features pertinent to the type of study being done<sup>30</sup>;
- have the full representation of switching algorithms of power electronic converters for power system harmonic studies;
- have all pertinent *protection systems* modelled in detail for *power system* transient and voltage stability analysis, including balanced and unbalanced fault conditions, *frequency* and *voltage* Disturbances, and multiple fault conditions and can disable the *protection systems* if required;
- be configured to match expected site-specific equipment settings;
- allow plant capacity to be scaled;
- ~~for~~ transient stability EMT-type models, must correctly operate for integer time steps in the range of 10 to 50 microseconds and have consistent performance across this range of time steps; operate with a time-step greater than or equal to 1 microsecond, ideally consistent with the switching frequency of the plant.
- for EMT-type models used for harmonic analysis or real-time EMT simulations, time ~~steps must be such that it they~~ steps lower than 10 microseconds are permitted to allow<sup>s</sup> for an accurate representation of the switching algorithm of semiconducting devices;
- allow model re-entry<sup>31</sup> (e.g. PSCAD™/EMTDC™ snapshot) to facilitate integration into larger system ~~models~~ studies;
- support multiple-run features to facilitate iterative studies;
- allow multiple instances of the model within the same simulation;
- be capable of self-initialisation, with initialisation to user defined terminal conditions within three seconds of simulation time;
- warn the user by way of a message to the progress output device when the system conditions are beyond *plant* operational limits or otherwise not consistent with valid operating conditions for the *plant*; and
- clearly identify the manufacturer's EMT model release version and the applicable corresponding hardware firmware version.

<sup>28</sup> ~~AEMO has adapted several of these requirements from EMT modelling recommendations made by the Electranix Corporation.~~

<sup>29</sup> The model cannot use the same approximations classically used in transient stability modelling, and should fully represent all fast inner controls, as implemented in the real equipment. It is possible to create models which embed (and encrypt) the actual hardware code into an EMT component. This is the recommended type of model.

<sup>30</sup> This may include external voltage controllers, plant level controllers, customized PLLs, ride-through controllers, SSCI damping controllers or others. Further details of required electrical and mechanical components are provided in Appendix C.

<sup>31</sup> This refers to the ability for a model to use the PSCAD™/EMTDC™ Snapshot feature, whereby the states and variables in an EMT model can be frozen in time and saved in a Snapshot file. The model can then be initialised in this state in subsequent simulations. For more information, please consult the "Initialization and Initial Conditions" section of the PSCAD™ on-line help system.

### Multiple voltage disturbances

The EMT model provided must account for any the most restrictive<sup>32</sup> electrical, mechanical, or thermal limitations-protection of the *plant* with respect to multiple *voltage* Disturbances in quick succession, and calculate dynamically and accumulatively the impact of multiple *voltage* Disturbances, including but not limited to the following factors:

- heat dissipation across the dynamic braking resistors (if applicable);
- capability of auxiliary supplies, e.g. uninterrupted power supply (**UPS**);
- torsional stress protection and fatigue on shaft drive train and prime mover (if applicable);
- protection associated with tThermal design limits\_of the integral assembly of the *plant*, and
- any other relevant electrical, mechanical or thermal protection.

Note that these requirements apply only to EMT models as the simplifications of RMS *plant* models may result in inaccurate activation of fault ride-through mechanisms for unbalanced faults.

#### 163.4.54.3.5 Accessible variables

Where applicable, all models must allow alteration to the following:

- all applicable set-points within all *plant* including (must be adjustable before and during a simulation run):
  - *Active power*
  - *Reactive power*
  - *Voltage*
  - *Power factor*
  - *Frequency*

for example, for a *generating system* this infers access to all applicable set-points;

- deadband, droop, delays (including communication delays) and slow<sup>33</sup> outer loop controls for any applicable control system such as *frequency* and *voltage* control;
- ramp rates for changes in active power;
- *voltage* and *frequency* protection settings, such as over/under *voltage* protection and over/under *frequency* protection;
- fault ride-through activation and deactivation thresholds, including any multiple-fault ride-through limits and hysteresis levels;
- active and reactive current injection/absorption settings during a fault;
- number of in-service *generating units* and reactive support *plant*, adjustable before and during a simulation run; and
- energy source input (e.g. wind speed or irradiance), adjustable before and during a simulation run without causing any adverse impact on initialisation or dynamic performance.

Additional alterable variables may be required by AEMO or the NSP to undertake full stability impact assessment as described in the *system strength impact assessment guidelines*. For example, proportional and integral gains for inner/outer current/*voltage* control loops (including PLL, DC link current and *voltage* control, and any other control loops which can have a system strength impact). These variables can be adjusted by means of applying a real number multiplier if the actual values of these gains are preferred to remain black-boxed.

<sup>32</sup> It is the Applicant's responsibility to determine which protection element(s) will be the most limiting factor for multiple fault ride-through.

<sup>33</sup> Adequate for simulating actions of on-load tap changing *transformers*, static reactive *plant* switching, and 60 seconds Contingency FCAS.

**163-4-64.3.6 Model outputs**

Table 4 outlines the output quantities required to demonstrate model performance for a variety of dynamic analysis scenarios. Quantities used to determine model accuracy are typically a sub-set of these quantities, and are described in Appendix D.

**Table 4 Required model output quantities**

Plant type	Plant internal quantities	Plant terminal measured quantities
<b>Synchronous machines</b>	Field current <sup>A</sup> Field voltage Limiter outputs <sup>B</sup> Mechanical power or torque Rotor angle PSS output <sup>G</sup> Unit speed AVR output <sup>C</sup> Exciter output Valve position <sup>G</sup> Guide vane/needle positions <sup>G</sup> Governor control output <sup>G</sup> Set-point for active power <sup>G</sup> Set-point for voltage External protection relay(s) status <sup>H</sup>	
<b>Wind (generating unit)</b>	DC link voltage and current Error/status codes <sup>D</sup> Generator rotor speed Active and reactive currents Mechanical torque or power Pitch angle Quantity determining FRT activation Set-point for active power Set-point for reactive power, voltage or power factor	Active power Total current <sup>E</sup> Frequency Reactive power
<b>Solar (generating unit)</b>	DC link voltage and current Error/status codes <sup>D</sup> Active and reactive currents Quantity determining FRT activation Set-point for active power Set-point for reactive power, voltage or power factor	Voltage magnitude <sup>E</sup> Voltage phase angle
<b>Battery (generating unit)</b>	DC link voltage and current Energy storage level Error/status codes <sup>D</sup> Active and reactive currents Quantity determining FRT activation Set-point for active power Set-point for reactive power, voltage or power factor	
<b>HVDC link</b>	DC link voltage and current Firing angle (for LCC HVDC) Switch / valve currents <sup>A</sup> Error/status codes <sup>D</sup> Active and reactive currents Quantity determining FRT activation Set-point for active power Set-point for reactive power, voltage or power factor External protection relay(s) status <sup>H</sup>	

Plant type	Plant internal quantities	Plant terminal measured quantities
Reactive compensation plant (SVCs, STATCOMs, etc.)	DC link voltage and current Shunt control status/set-points External plant set-point outputs Error/status codes <sup>D</sup> Active and reactive currents Quantity determining FRT activation Set-point for reactive power, voltage or power factor External protection relay(s) status <sup>H</sup>	
Centralised controllers (park and hybrid controllers)	Error/status codes <sup>D</sup> Quantity determining FRT activation Set-point for active power <sup>F</sup> Set-point for reactive power, voltage or power factor <sup>F</sup> External protection relay(s) status <sup>H</sup>	

A. In EMT models only.

B. Relevant limiter outputs, such as over-excitation limiter, under-excitation limiter, V/Hz limiter etc.

C. Including outputs of any compensation components.

D. Only those error/status codes which translate into a distinct electrical system response at the LV terminals of the plant. For example, normal, fault, stop, LVRT or HVRT activation, unstable mode identification etc.

E. Both waveform and RMS values for EMT models.

F. As sent to generating units within the generating system.

G. Not applicable for synchronous condensers.

H. External discrete protection relays relevant to the plant. For example, for transient stability studies, this may include over- and under-voltage, over- and under-frequency, RoCoF and reverse-power protection. For black-start studies, this may be extended to include negative sequence, out-of-step, over-fluxing, loss-of-excitation and generator and unit-transformer differential protection.

In addition to these internal and terminal quantities, models should provide access to the aggregated reticulation network and point-of-connection or unit transformer LV and HV to demonstrate the complete generating system performance.

### 163-4.74.3.7 Integration compatibility

A model submitted to AEMO and the NSP for any power system element must operate as part of a full power system model alongside models of many other power system elements. This will inevitably include elements of the same type as the one in question, using either the same or a different release version of the same model code, submitted by the same or another Registered Participant.

It is, therefore, imperative that the model is capable of coexisting and operating correctly alongside other independent instances of the same model, either of the same version or with a different version number. This requires attention as a minimum to the following:

- naming and referencing models, functions and libraries based on a version number, such that two different versions of a model of the same plant can run within the same simulation environment without interference;
- creating models to work for a range of time steps and dynamic simulation parameters, rather than for specific settings only;
- avoiding the use of global (FORTRAN COMMON) variables, including subroutine-level static (FORTRAN SAVE) variables, with persistent values, except where dynamic allocation is used to create instance-specific copies of such variables; and
- models should, to the maximum extent practical, make use of the mechanisms provided within the host software platform to encapsulate separate model instances (for example, the pre-allocated STATES and VARs in PSS®E).

Additionally, for EMT models, integration compatibility is improved by:

- Having all plant and control system models contained within a single EMT case, rather than spanning across a simulation set.
  - Methods used to split a single plant's model components across several files for (typically SMIB) processing speed improvements may not be compatible with the broader case

into which it will be integrated. Applicants must consult with AEMO and the NSP if simulation sets are required.

- Having dependencies on a minimal number of external files.
- Model dependencies on external files having user-settable naming references.

Models that prove problematic to integrate into larger cases will need to be rectified before AEMO and the NSP are able to accept the model for further assessment. AEMO and the NSP will work with the Applicant to identify the issues.

#### **163.4.84.3.8 RMS model source code**

Source code of the RMS simulation model must be provided to AEMO, including all elements of the *plant* that affect its dynamic response, such as:

- For a *generating system*, the *generating unit* model(s).
- Supervisory controls acting on the *plant* as a whole.
- Dynamic reactive support *plant*.
- Coordination of multiple reactive support devices and hybrid facilities.
- Any other *plant* such as *transformer* tap-changers whose response can reasonably impact the overall dynamic performance of the *generating system*.

The model must be written and prepared using good model writing practices utilising the most recent model writing features and capabilities for the relevant software. For example, this would include the following:

- the models of the controllers and items of *plant* must be easily identifiable.
- the code should be commented to identify major components.
- execution of dynamic data documentation commands should not result in model crashing;
- the model code should ensure correct implementation of windup and non-windup limits; and
- the model code should implement division and square root operations in a 'safe' manner to avoid division-by-zero and similar exceptions.

Additionally, for PSS@E RMS models:

- using models which include calls into either of the CONEC or CONET subroutines is not acceptable. These calls can be avoided by adhering to 'table driven model' conventions in the model implementation. As of PSS@E version 34, table-driven models may be associated with most power system elements;
- execution of the DOCU command should show all model states, outputs and constants that are observable/adjustable externally. The output format of these commands should be consistent with the format of dynamic data records;
- using identical names should be avoided for models of similar structure where the number of one of the CONs, ICONs, VARs, or STATES is different between the two models; and
- the use of auxiliary or linking files is not acceptable.

#### **163.4.94.3.9 RMS model format**

RMS models submitted to AEMO for the purposes of load flow, fault analysis and conventional transient stability studies must be compatible with PSS@E version [32 or 34](#).

RMS models submitted to the connecting NSP must be compatible with the software package nominated by the NSP where an NSP uses a different RMS-type simulation tool, such as DlgSILENT Power Factory. RMS models should not have dependencies on additional external commercial software.

AEMO accepts RMS model source code natively developed in FORTRAN 90 or higher. FLECS code is no longer accepted.

### **163.4.104.3.10 EMT model format**

EMT models provided to AEMO and the NSP must be compatible with PSCAD™/EMTDC™ version 4.6 and above and Intel Visual FORTRAN version 12 or higher. Models must not be dependent on a specific Intel Visual FORTRAN version to run. EMT models compiled in, or requiring GNU FORTRAN or Compaq Visual FORTRAN to run will not be accepted.

EMT models should not have dependencies on additional external commercial software, however dependencies on free, commonly available redistributable libraries (such as E-TRAN) may be acceptable.

### **163.54.4 Conventional EMT model requirements**

Section 4.4 outlines the modelling requirements for conventional EMT studies that AEMO and the NSP may undertake outside of the *plant connection* process.

Models provided for these studies must comply with all EMT model requirements defined in Section 4.3, in addition the requirements below.

[These requirements are not general requirements. They apply to relevant \*plant\* technologies only.](#)

#### **163.5.14.4.1 Black start model requirements**

EMT models and simulations are required for adequately assessing the performance of *plant* and the *network* in black start scenarios. Models and Data Sheets [for \*plant\* involved in \*power system restoration\*](#) must be consistent with the [Switching and lightning high-frequency transient model](#)<sup>34</sup> requirements of the tables within Appendix C, and include additional elements as follows:

##### **Generator (Applicant provided):**

- Major auxiliary loads including [all large](#) fans and pumps greater than 1 MW each. The information provided should include the size and number of motors, their inertia, and operational reactances and time constants, and whether directly connected or interfaced via a variable speed drive.
  - Including details of the transformers that supply the auxiliary loads.
- Descriptions of any special abilities of the *plant* (e.g. soft-start capable, TTHL bypass valves etc.).
- A detailed description of any special control schemes active during system black (e.g. changes to governor PID controllers while in isochronous mode).
- Surge arrester manufacturer, types, and V-I profiles.

##### **Network (NSP provided):**

- Geometrical representation of *transmission lines*, including conductor type and associated resistance, cable bundling configuration, transpositions (for lines above 5km), tower types and spacing.
- *Transmission network transformers*, including saturation profile, air core reactance, winding configurations, number of limbs, all reactances and time constants.
- X and Y *transformer* differential protection relays, with on-site settings.
- Locations of synchronising breakers and synchrocheck relay settings
- Details of under- or over-*voltage* protection schemes active in key *network* corridors.
- Surge arrester manufacturer, types, and V-I profiles.

##### **Reactive support plant (NSP provided):**

- Full representation of the reactive support *plant* and all *control systems*.
- Step-up *transformers*, including saturation profile, air core reactance, winding configurations, number of limbs, all reactances and time constants.
- All relevant X and Y protection relays with on-site settings.

<sup>34</sup> [These models must represent fast- and slow-front transients as defined by the IEC Standard 60071 Part 1.](#)



- A detailed description of any special control schemes relevant during system restoration (e.g. gain reduction for SVCs, etc.).
- Surge arrester manufacturer, types, and V-I profiles.

#### **163-5.24.4.2 Sub-synchronous model requirements**

These studies are specialised and are not conducted routinely. If AEMO and the NSP determine that such studies are required to support secure system operation, adequate EMT models must be made available by the asset owners to facilitate the studies. Models provided for these studies must comply with all EMT model requirements defined in Section 5.4, in addition the requirements below.

#### **SSR**

In addition to standard *generation* model components, owners of conventional synchronous generators may be required by AEMO and the relevant NSP to model the turbine-generator mechanical system as a lumped-mass model if it is determined that sub-synchronous resonance studies are required for the *plant* under consideration.

The lumped-mass model consists of multiple masses representing different turbine shaft sections with each individual mass defined by its portion of mechanical torques, inertia constants, torsional stiffness between adjacent masses, and damping coefficient associated with each mass<sup>35</sup>.

Models used for such studies can be confirmed through a combination of:

- Factory acceptance testing of the turbine-generator mechanical system.
- Using measured generator terminal quantities and performing a discrete or fast Fourier transform to confirm the frequencies of the torsional modes, which is then compared against the calculated torsional mode frequencies using inertial constants and stiffness. This applies to existing synchronous generators only.

#### **SSCI/SSTI**

The level of detail required for these studies are provided under the “sub-synchronous interaction” entries of tables in Appendix C.

#### **163-5.34.4.3 Format**

EMT models for conventional EMT study purposes must be submitted in the format specified in Section 4.3.10.

### **163-6.4.5 Small-signal model requirements**

Small-signal stability models are required for *plant* that contribute to local, intra-regional and inter-regional frequency modes in the *power system*. This may include synchronous *generators* and their PODs, dynamic reactive support plant with PODs, and any other *plant* which can reasonably impact damping of small-signal oscillations as determined by AEMO and the relevant NSP.

A fully validated RMS transient stability model is generally sufficient for this analysis, provided that the corresponding small-signal model can be derived from it using standard mathematical linearisation techniques.

#### **163-6.14.5.1 Format**

Small signal stability models are constructed by AEMO or the NSP from the model block diagrams and model source code submitted as part of the model package. Where models cannot be readily linearised from the block diagram or source code based on the extent of information provided, additional information may be required from the Applicant.

---

<sup>35</sup> Information on damping coefficient is typically difficult to acquire, and is a function of the turbine-generator output. The information on inertia constants, torsional stiffness between adjacent masses and the portion of mechanical torque attributed to each mass must be provided.

## 163.74.6 Power quality model requirements

The following sets out the requirements for power quality models.

### 163.7.14.6.1 Harmonic Emissions

Harmonic current injection models used for harmonic frequency scans and harmonic distortion analysis in conventional *power system* harmonic analysis tools must provide:

- *frequency*-dependent Norton equivalences of each type of *generating unit*;
- harmonic current injection profiles (for each harmonic order) at each *generating unit*, including:
  - harmonic current magnitude, e.g. in Amperes, or in percentage of fundamental current;
  - harmonic current phase angle (only if the harmonic emission calculation method advised by the relevant NSP requires this information);
- adequate model of collector grid<sup>36</sup>;
- *generating unit* transformer models and *generating system* transformer models<sup>37</sup>; and
- data for harmonic filters (if present) must be provided, including connection point(s) of the filters, filter layout (e.g. single-tuned, double-tuned), quality factor and electrical parameters; and
- where EMT-type models are used for harmonic analysis the requirements set out in Section 4.3.10 will apply<sup>38</sup>.

The origin and methodology of the Norton equivalent sources must be documented and provided. Where harmonic current injections sources are provided in the form of harmonic current magnitude only, a method needs to be applied to summate the effects of the many individual harmonic sources in the *plant*.

A common method that has been used is the IEC Second Summation Law, as defined in IEC TR 61000.3.6-2012. From one of the findings documented in CIGRE Technical Brochure 672, “Power quality aspects of solar power”, the standard summation exponents are not suitable to be used.

For photovoltaic *generation* using multiple inverters of the same manufacturer, harmonic currents should be added arithmetically independent of the harmonic order. Currently, no such finding has been published for wind *generation*, however, until different findings for wind *generation* are published, the same approach of applying arithmetically sum can be adopted for wind *generation*.

#### Format

Harmonic models must be provided in a format that is compatible with the harmonic analysis software platform nominated by the relevant NSP. This can be divided into types of simulation tools:

- Conventional harmonic simulation tools based on current injection techniques.
- EMT-type simulation tools where all requirements specified above will remain valid.

Depending on the specifics of the *connection point* and proximity to other sources of harmonics, both types of simulation models may be needed for a given *connection*.

### 163.7.24.6.2 Harmonic susceptibility and resonances

To account for the harmonic signature of *asynchronous plant* in harmonic susceptibility and resonance studies, it is necessary to include appropriate harmonic models of the harmonic generating devices, the harmonic impedance profile of the *network*, and the *frequency* dependent behaviour of the *network elements*. Where EMT harmonic susceptibility and resonance studies are required, model components as outlined within Appendix C for harmonic studies must be included.

<sup>36</sup> Collector conductor models may need to consider skin and conductor proximity effects.

<sup>37</sup> Positive, negative and zero sequence impedance of these *transformer* models must be provided, including any earthing arrangement and *transformer* vector groups.

<sup>38</sup> This is not a general requirement and will be determined on a case-by-case basis and only when the conventional harmonic analysis techniques fail to achieve the required level of accuracy.

## Format

Models used for harmonic susceptibility and resonant analysis must be provided as an EMT model complying with the format requirements of Section 4.3.10. The EMT model must comprise all control systems and switching components that contribute to the *plant's* harmonic profile. Further details of required components are provided in the “Harmonics” entries of the tables in Appendix C.

### ~~163.7.34.6.3~~ Flicker

The simulated rms *voltage* magnitude/voltage waveform obtained from either RMS or EMT time-domain simulation can be fed into a flicker meter model following IEC 61000-4-15 for assessing the short-term and long-term flicker severity. These time-domain models are expected to include adequate representation of characteristics/functions/control systems involving/causing flicker.

## Format

Models must comply with the RMS and EMT format requirements of Section 4.3.9 and Section 4.3.10.

### ~~163.7.44.6.4~~ Voltage unbalance

Models provided for harmonic studies are sufficient for *voltage* unbalance studies from a *generator* source perspective, however *network* elements that adequately represent *voltage* unbalance must also be included.

Models used to investigate this phenomenon must include the following:

- Steady state 50 Hz negative-sequence current injection, both magnitude and phase angle (phase angle is relative to the 50 Hz positive-sequence current phase angle), from the devices connected at the assessed bus must be modelled.
- *Transmission lines* must be modelled in the form that the information of 50 Hz negative-sequence impedance and the coupling impedance linking 50 Hz negative-sequence voltage and 50 Hz positive-sequence current are captured (for example, geometrical line representation).
- Negative-sequence impedances for synchronous machines and loads must be modelled.
- A variation of different power flow scenarios as well as other Steady State 50 Hz negative-sequence current injection devices must be modelled to capture the variations of the background network 50 Hz negative-sequence voltage contribution.

Additionally, known *voltage* unbalance susceptibility within the *plant* must be represented within the *voltage* unbalance model and provided within documentation.

## Format

Models for voltage unbalance studies must be compatible with:

- the EMT model format requirements specified in Section 4.3.10; or
- a suitable power quality analysis tool as nominated by the relevant NSP.

### ~~163.84.7~~ Model aggregation

Traditionally there has been a one-to-one correspondence between *power system* elements such as *generating units* and the models of these elements in simulation software. Thus, each *generating* unit has been represented individually in the *power system* model. This is practical when typical *power system plant* were large *power stations* comprising up to about half a dozen individual large *generating units*. However, contemporary *generating systems* such as wind and solar farms, as well as other *plant* such as grid-scale battery installations, can include as many as several hundred *generating units*. As these *generating units* are usually identical to one another, this has the effect of multiplying the required computational effort and simulation run time for little benefit, compared to representing these identical *generating units* as a smaller number of aggregates.

For *power system* modelling purposes, the general rule is that the submitted *plant* model should contain **no more than four *generating units* of any one type**. Where the number of *generating* units is greater,

they should be combined into aggregates with each aggregate representing multiple individual *generating units*. In the simplest cases, a single aggregate may suffice to represent the totality of *generating units*.

Aggregation should not be used to combine *power system* elements of differing types. These should retain separate explicit model representations, albeit some may be aggregates of identical units of that same type. An exception may be made where elements are similar in all material respects other than size (for example a 3.0 MW and a 3.2 MW wind turbine with the same underlying technology and control systems) and where evidence is provided of this similarity by way of manufacturer documentation, to the satisfaction of the NSP and AEMO.

#### **463-8.14.7.1** **Scaling principles for derivation of multiple-unit aggregates**

The following general principles are assumed as the default for producing aggregates of N identical units, where each unit is assumed to consist of a '*plant*' at low *voltage (LV)* in cascade with a unit *transformer* stepping up to medium *voltage (MV)*.

The MV 'collector system' which connects the individual *generating units* together is treated separately in Section 4.7.2.

Where the modelling of *power system plant* requires an aggregation method that varies from these principles, this must be clearly documented in the RUG. Alternative aggregation methods include the provision of a separate aggregate model not directly derived from the individual unit model. Evidence must be submitted to AEMO and the relevant NSP for the suitability of the aggregation method relative to the simple application of the scaling principles below. AEMO and the NSP must jointly assess this evidence, and may accept the different method, or determine that the scaling principles will apply if the evidence submitted is weak.

- The aggregate *generating unit* is represented in the model in an analogous fashion (size aside) to a single *generating unit*. It has the same associated dynamic model and appears similar to a *generating unit* in the *network* model in cascade with an equivalent unit *transformer*.
- The LV and MV voltage levels are the same for the aggregate as for the individual *generating units*.
- The MVA rating of the aggregate *plant* is N times the MVA rating for an individual *generating unit*. (This rating is called MBASE in the PSS®E software.)
- The *active power* and *reactive power* of the aggregate are the sums of the individual *generating unit* powers. For modelling purposes, there is an underlying methodological assumption that each *generating unit* has identical power outputs, although these will vary from unit to unit.
- Any other 'size quantities' specified in SI units, or in per-unit on a fixed system MVA base, are multiplied by N in the aggregate. Examples of size quantities are rated current in Amperes, rated torque in Newton-metres, and inertia constant in Joules or VA-seconds (but *not* speed or voltage). Where, on the other hand, the model specifies these quantities in a per-unit system on the *generating unit* MVA base, their numerical values are identical.
- The MVA rating of the aggregate *generating unit transformer* is N times the MVA rating of each *generating unit transformer*.
- Any internal series impedances of the aggregate *generating unit*, *generating unit transformer* and any intervening LV cables, when specified in ohms or in per-unit on a fixed system MVA base, have values 1/N times their values for each corresponding *generating unit*. Where, on the other hand, the model specifies these quantities in per-unit on the unit MVA base, their numerical values are identical.
- Any internal shunt admittances of the aggregate *generating unit*, *generating unit transformer* and LV cables, when specified in Siemens or in per-unit on a fixed system MVA base, have values N times their values for each corresponding *generating unit*. Where, on the other hand, the model specifies these quantities in per-unit on the unit MVA base, their numerical values are identical.

Implicit in these scaling principles is a requirement that the underlying model of the unit is also capable of representing the aggregate of N units when configured with the larger MVA rating. If appropriate, the

model may be coded to indicate the level of aggregation explicitly in the model configuration (for example, by including either each unit size or the number N of identical units as a configuration parameter). However, any necessary change to model configuration or settings beyond those stated above when switching between an individual unit and aggregate representation, or between aggregate representations with different numbers of units, must be clearly documented in the RUG.

#### **463-8-24.7.2 Representation of collector systems in aggregated models**

Special attention must be given to the aggregated representation of the MV ‘collector system’ that connects the MV terminals of the *generating unit transformers* and (usually) conveys the aggregate *generated* or consumed power to an MV *collector bus* at the relevant substation.

In the simplest case, all identical *generating units* are combined into a single aggregate, and the model specifies a single equivalent collector impedance connected between the MV collector bus and the MV terminal of the aggregate equivalent *generating unit transformer*. In this case, the recommended procedure for calculating the equivalent collector impedance is given in National Renewable Energy Laboratory (NREL) report NREL/CP-500-42886, “Method of Equivalent for a Large Wind Power Plant with Multiple Turbine Representation”<sup>39</sup>. This procedure is based on calculating the equivalent series resistance and reactance that yield the same *active power* and *reactive power* consumption as the original MV collector system, where the units in that system are assumed for simplicity to all operate at identical *voltage*.

The same procedure must be applied when the system is divisible into up to four component subsystems, each with its own independent *connection* to an MV collector bus. In this case, each subsystem furnishes its own aggregate with the equivalent collector impedance calculated as above.

The Applicant may propose an alternative aggregation method to the NSP and AEMO, who will jointly assess it. An alternative method is required in any case where the *plant* layout does not readily fit in either of the two categories above. As a matter of principle, it is noted that there is no one correct way to aggregate any collector system, and different principles such as equalising losses (as per Muljadi et al), or reproducing an equivalent MV *voltage* diversity, will yield different results. All aggregation methods implicitly induce a degree of modelling error which must be acknowledged whenever comparisons are undertaken between modelled and true *plant* behaviour.

#### **463-8-34.7.3 General considerations**

For a *generating system* with many *generating units*, provision of the required aggregate model will be the primary method considered for wider *power system* studies and for AEMO’s own assessment tools.

Aggregate models should continue to provide access to the LV terminal bus quantities for each aggregate equivalent *generating unit*, specifically *active power*, *reactive power* and *voltage* magnitude. This includes EMT models that have been black-boxed. Figure 2 shows a high level example of how an EMT model that has been aggregated and black-boxed can provide access to terminal quantities.

<sup>39</sup> Muljadi et al, 2008.

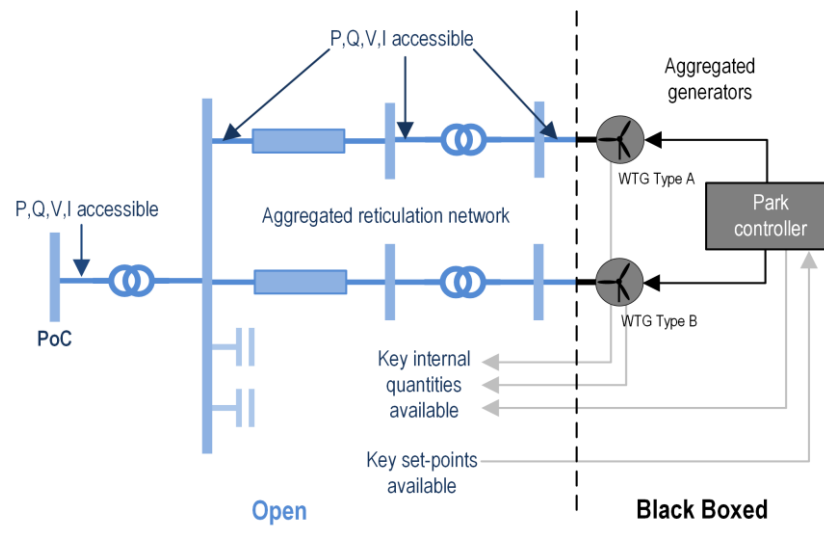

**Figure 2 Aggregated and Black-Boxed EMT model high level representation**

For model validation purposes, both the individual *generating unit* and aggregated *generating system* responses must conform to the accuracy requirements in Section 6.2. The procedure for R2 validation will involve collecting field measurements both for the aggregate *generating system* and for one representative *generating unit* for validation.

High voltage *plant* connecting directly to the *transmission network* is to be explicitly modelled.

### 163.94.8 Model and plant updates

While each submitted model must be a faithful representation of the *plant* at the time of submission, it is natural to expect that updates to the model will be issued from time to time by the supplier or other party responsible for the model.

It is especially important that alterations to the *plant* or its control firmware that alter the *plant's* dynamic performance are correctly reflected in an updated simulation model. It is also possible for several reasons for model updates to be proposed without any change to the *plant*.

#### 163.9.14.8.1 Updates to account for simulation model improvements

The reasons for model updates relating to simulation improvements include the following:

- Updates to improve computational or numerical performance of the model code.
- Updates to incorporate additional functionality provided with newer versions of the same equipment, or to allow greater flexibility in configuration.
- Updates to broaden the scope of the model code to represent multiple equipment types within the one family, by varying the configuration parameters.
- Updates to correct ‘bugs’ or unanticipated performance issues, particularly to reflect novel ‘use cases’ arising during long term operation.

In general, an update to a model held by AEMO and the NSP for specific *power system plant*, in the absence of any alteration to the *plant* itself, will be considered only where it is relevant to the performance of that element in ongoing dynamic assessments (including the performance of the simulation software itself). Where the update is relevant only to accommodating future *plant* using the same model, it is generally expected that the existing *plant* will continue to use the ‘old’ model, which will continue to perform adequately after new *plant* are introduced using the updated model version.

The updated model’s acceptance by AEMO and the relevant NSP will be subject to additional dynamic model acceptance testing conducted by AEMO or the NSP at the Applicant’s expense.

### 163.9.24.8.2 Updates to account for changes in the plant including parameter changes

Updates to *plant* firmware or settings that alters dynamic performance or protection operation must be captured in a revised dynamic model(s) to be submitted to AEMO and the NSP. The revised dynamic model(s) must be accompanied by a report that shows the revised model(s) and its settings meets all accuracy requirements to 'R1'<sup>40</sup> level, prior to acceptance of *performance standards* for the altered *plant*<sup>41</sup>. This will be followed by on-system tests as part of plant commissioning, including tests to validate the revised dynamic model(s) to R2 level.

The updated model's acceptance by AEMO and the NSP will be subject to additional dynamic model acceptance testing conducted by AEMO or the NSP at the Applicant's expense.

### 163.9.34.8.3 Updates to account for later versions of simulation tools

Occasionally<sup>42</sup>, it may be necessary for AEMO and the NSP to move to later versions of RMS and EMT simulation tools. Ideally, later versions of these simulation tools will be backwards-compatible with existing models, or where AEMO has the source code for RMS models, AEMO will independently recompile the model and update model libraries.

However, if AEMO or the NSP deem it necessary that a later version of a simulation tool is required to undertake studies, and an Applicant's existing model no longer functions correctly in the later version of the simulation tool, an update to the Applicant's model is required to provide compatibility with the later version of simulation tool. This model update is required from the Applicant without cost to AEMO or the NSP. These updates may be required at any point in the life of the *plant*.

## 164.5. MODEL DOCUMENTATION

Information required for the modelling of *power system plant* for all applicable studies including load flow and fault level studies, specialised studies, black-start studies, power quality analysis, connection assessments, stability assessments and *system strength impact assessments* is required in a number of forms. For example:

- the RUG, required under clause S5.2.4(b)(8) of the NER, for both RMS and EMT models<sup>43</sup>;
- completed Data Sheets, required under clause S5.2.4(a);
- functional block diagram information for RMS models, required under clause S5.2.4(b)(5); and
- model source code information for RMS models, required under clause S5.2.4(b)(6).

This model information must be consistent. For example:

- the specific parameters relevant to a dynamic model required in tabular form by the Data Sheets, must be found in the functional block diagrams, also required by the Data Sheets<sup>44</sup>;
- the functional block diagrams for RMS models required by the Data Sheets, must match the functional block diagrams provided under clause S5.2.4(b)(5); and
- the functional block diagrams for RMS models provided under clause S5.2.4(b)(5) must match model source code information provided under clause S5.2.4(b)(6).

<sup>40</sup> 'R1' refers to *pre-connection* in the sense that it is used in clause S5.5.6 of the NER.

<sup>41</sup> See clause 5.3.10 of the NER for *Generators*. NSPs have a general obligation to ensure that modelling data used for planning, design and operational purposes is complete and accurate at all times and provide it to AEMO and other NSPs if reasonably required to model the static and *dynamic performance* of the *power system* (see clause 5.2.3(d)(8) & (9)). MNSPs and *Customers* cannot *connect* altered equipment until an *application to connect* is made and a *connection agreement* is entered into (see clause 5.2.3(g) and 5.2.4(b), respectively).

<sup>42</sup> For example, since 2009 AEMO has needed to change PSS@E versions twice: v29 to v32, and v32 to v34 (currently co-supported), and PSCAD™ versions once: v4.2 to v4.6.

<sup>43</sup> Where the requirement to provide a RUG arises by virtue of the application of clause S5.5.7(b1)(1)(i), the requirement applies to all *generation*, not just *generation* with a nameplate rating of  $\geq 30$ MW.

<sup>44</sup> The identical numerical value may not match between the parameter requested in the table and the functional block diagram due to differences in units, or a requirement to provide parameter information in a functional block diagram in 'per unit' form, however, it is expected that the parameter is recognisable in the functional block diagram.

### 164.15.1 Releasable User Guide

The RUG accompanies a model to describe how it is to be used and includes other information such as *transformer* modelling information, operational information, information on *protection systems* or *control systems* that are relevant to the assessment of proposed *performance standards*, and *connection point* information. This information in a consolidated form is required to facilitate the *connection* and other studies and to avoid misinterpretation and potential errors.

The RUG is routinely sent to *Registered Participants* as required by the NER, and as such, should not contain any information that is considered confidential. The RUG must be written such that a *Registered Participant*, without any prior knowledge of the *plant*, would be able to successfully perform studies.

RUGs must comply with the template set out in the Guideline for Preparation of a Releasable User Guide<sup>45</sup>.

### 164.25.2 RMS and EMT Model Documentation

Supporting documentation included in the RUG must be relevant to the site-specific model and must contain sufficient information for AEMO and the NSP to use the RMS and EMT models to carry out due diligence and *power system* studies.

The information in the supporting model documentation includes:

- Information that is necessary to allow modelling of the *plant* (in the case of *generation*, both each *generating unit* and *generating system*) for *connection* assessment and other *power system* studies;
- Instructions on the use and operation of the RMS and EMT models, including operational limitations;
- include descriptions and setting values for control sequences (e.g. fault ride-through control schemes and any other relevant *control systems*) that are relevant to the intended use of the model;
- Descriptions, site-specific values and ranges of all configuration parameters, component trip/status codes used in the RMS and EMT models; and
- Descriptions, site-specific values and ranges of all user-adjustable variables and *control system* settings contained within the model.

#### 164.2.15.2.1 Additional information required for fault level calculations

Additionally, *plant* using converter *connected* technologies must:

- state within the RUG timeframes within which short circuit related parameters of the supplied model are appropriate; and
- provide information on the magnitudes and phase angles of the phase-current *connection point* contributions that their equipment is expected to make (as a function of *connection point voltage-dip* magnitude and duration) for the following types of voltage dips:
  - in only one phase;
  - equal dips in two phases and none in the third; and
  - equal dips in three phases.

#### 164.2.25.2.2 RMS model block diagrams

Block diagrams must be submitted alongside all RMS models. Several attributes will be assessed:

- The transfer function block diagram must include all functional controllers and *plant* that materially affects the performance of the model<sup>46</sup>.

<sup>45</sup> Available at: [http://www.aemo.com.au/-/media/Files/Electricity/NEM/Network\\_Connections/Transmission-and-Distribution/Guideline-and-Template-for-preparation-of-a-Releasable-User-Guide](http://www.aemo.com.au/-/media/Files/Electricity/NEM/Network_Connections/Transmission-and-Distribution/Guideline-and-Template-for-preparation-of-a-Releasable-User-Guide)

<sup>46</sup> Included in this category are the central park level controllers that schedule active and reactive power across the wind and solar farms.



- The models of the controllers and items of *plant* must be easily identifiable.
  - All individual blocks should be expressed explicitly. The use of black-box type approach for representing any of the individual transfer function blocks is not acceptable.
  - The interconnection of the different functional controllers and the items of *plant* must be clearly shown.
- Images and tables embedded in documents must be of sufficient resolution to easily identify all components, parameters and values.
  - The transfer function block diagram must be described by Laplacian transfer functions.
  - The transfer function blocks and model parameters must be recognisable in terms of the physical design of the *plant* and *control system* settings, to allow the NSP or AEMO to assess *control system* settings proposed by the Applicant, or design new settings.
  - The transfer function blocks and model parameters must include any relevant non-linearities, such as limits, arithmetic or mathematical functions, deadbands or saturation, etc. Any limits must be shown as windup or non-windup limits. Non-windup limits must show how the non-windup nature of the limit is achieved (e.g. which model state variable is being limited and the relationship between the limit value and the state variable that is being affected by that limit).
  - The model parameter values must reflect typical values appropriate for the actual equipment installed. All model parameters and their values must be shown either directly in the transfer function block diagram or in a tabular format.
  - *Control systems* with several discrete states or logic elements may be provided in flowchart format if a block diagram format is not suitable.
  - Parameter values that are intended to be (or can be) externally adjusted (e.g. those explicitly in PSS®E dynamic data file, VARs, CONs, ICONs etc.) must be clearly identified in the model block diagram.
  - The model block diagram and flowcharts (if applicable) must represent the corresponding model source code<sup>47</sup>.
  - The model inputs and outputs shown in the transfer function block diagram representation should match those indicated in the Data Sheets.
  - The state variables shown in the transfer function block diagram representation should match those indicated in the Data Sheets.
  - Model documentation and transfer function block diagram representation should be provided at the level of detail required for AEMO and NSPs to derive the corresponding linear small-signal model of the equipment.
  - Dynamic data must be provided as 'per unit' quantities on the machine MVA base.

### **164.35.3 Small signal stability model documentation**

Small signal stability models are developed by AEMO and the NSP from the model block diagrams (see Section 4.5). Generally, if the Applicant follows the requirements in Section 5.2.2 when developing model block diagrams, this process should yield sufficient information for small signal model to be successfully constructed and used by AEMO and the NSP.

Where the block diagrams are unclear, or where a linearised model has been provided by the Applicant directly, AEMO and the NSP require documentation that is sufficient to understand all components of the model and to perform small signal stability studies to their satisfaction.

---

<sup>47</sup> It is also expected that the functional block diagrams provided with the *Power System Design Data Sheet* and *Power System Setting Data Sheet* for a *generating system* will match these diagrams, although the parameter values might differ to reflect *connection point* performance requirements.

#### 164.45.4 Harmonic model documentation

Harmonic model documentation must be sufficient for the relevant NSP to understand and use the harmonic model in the software package of their choice. Where the harmonic model provided is an EMT model, the principles set out in Section 5.2 should be adhered to when developing documentation, with specific differences between the harmonic and transient stability EMT model highlighted.

Additionally, documentation for the harmonic model must include any or all of the following as agreed with the relevant NSP and AEMO on a case-by-case basis:

- Harmonic emission studies:
  - A harmonic profile at different loading levels, between 0 to 100%, in 10% steps if it is demonstrated the harmonic current profile varies linearly as function of the loading;
  - A suitable frequency-dependent Norton equivalent for the harmonic injecting device to clearly demonstrate how the current injected and the equivalent impedance vary as function of harmonic order;
  - Documents describing the suitability of the EMT-type model submitted consistent the level of modelling discussed in Appendix C.
- Harmonic susceptibility studies
  - Documents describing the suitability of the EMT-type model submitted consistent the level of modelling discussed in Appendix C.

#### 165.6. MODEL ACCURACY REQUIREMENTS

Section 7 specifies model accuracy requirements. These model accuracy requirements:

- are applicable regardless of the type of model provided; and
- will apply regardless of the type of *generating systems* and *plant*.

##### 165.16.1 Accuracy locations

Model accuracy must be demonstrated for all components within a *plant* that impact on *power system* dynamic performance.

*Synchronous plant* typically requires demonstration of model accuracy at each *generating units'* terminals.

Power electronic interfaced *asynchronous* technologies (such as wind and solar photovoltaic *generating systems*) may consist of several *generating units*, *plant* controllers, reticulation networks and dynamic reactive support devices such as STATCOMs and *synchronous condensers*. As such, demonstration of model accuracy must occur at:

- Connection point or high voltage terminals of plant transformers
- Reticulation *network* collector bus to which an individual item of dynamic *plant* is connected.
- *Generating units* (for each different type of *generating unit*, including batteries).
- Terminals of each type of dynamic reactive support device, such as STATCOMs and *synchronous condensers* (if applicable).
- Central park-level controllers, and any other overarching coordinated controllers.

##### 165.26.2 Model performance measures

The performance measures described in Section 7.2 must be used to determine the model accuracy, where all accuracy bands are to be referenced to the model's response. A table specifying quantities to which these requirements apply is provided in Appendix D.

General considerations are:

- The term “transient window” is used to describe the moment a reference change or Disturbance commences until the response returns to within  $\pm 5\%$  of the model’s maximum induced or reference quantity change. Appendix E provides a visual representation of this definition.
- Accuracy of EMT model responses are evaluated on their simulation-tool calculated RMS quantities<sup>48</sup>, with filtering appropriate for a 50 Hz nominal system. Larger filtering time constants on measurements will require justification.

#### 165-2-16.2.1 Accuracy criteria

The following criteria apply, and no criterion should override another, except where noted:

- For *synchronous plant control system* models, the overall linear response over a frequency bandwidth of at least 0.1–5 Hz must be within the following tolerances:
  - magnitude must be within 10% of the actual *control system* magnitude at any frequency; and
  - phase must be within 5 degrees of the actual *control system* phase at any frequency.
- For time domain responses that include non-linear responses or performance, as well as responses to switching or controlled sequence events (e.g. operation of fault ride-through schemes and converter mode changes), the key features of the response are within the following tolerances:
  - rapid slopes in the actual *plant* response, compared with the simulated response must be within the less restrictive of:
    - $\pm 10\%$  of the change for 95% of the samples within the transient window; and
    - from the start to the finish of the slope, a difference of less than 20 ms.
  - for rapid events caused by control sequences (such as some fault ride-through control schemes) or switching events, the sizes of peaks and troughs (measured over the total change for that peak or trough) must be within 10% of the change for 95% of the samples within the transient window;
  - oscillations in the actual response of the *plant* for *active power*, *reactive power* and *voltage* in the *frequency* range 0.1 to 5 Hz must have damping<sup>49</sup> and *frequency* of the oscillation within 10% of the simulated response for 95% of the samples within the transient window. The phase angle between different quantities (e.g. *active power* versus *reactive power*) at the oscillation *frequency* must be within 5 degrees. This does not apply to rapid events under paragraph (b), but applies to any subsequent oscillations;
  - the timing of the occurrence of the rapid slopes, events or the commencement of oscillations described in paragraphs (a)-(c) must be consistent with the *plant* characteristic that initiates the response<sup>50</sup>.
- Taking into account the *voltage* at the *connection point*, at any point during the simulation, the deviation of the actual measured responses from the simulated response for *active power* and *reactive power* must not exceed 10% of the total change in that quantity for 95% of the samples within the transient window. During periods of oscillatory behaviour, this criterion applies to:
  - the first cycle of the oscillatory response after the transient period (i.e. if associated with a fault, then after clearance of the fault and the transient recovery from the fault); and

<sup>48</sup> Per-phase RMS quantities for unbalanced Disturbances

<sup>49</sup> Measured as a rate of decay of the oscillation – e.g. halving time.

<sup>50</sup> This is a difficult criterion to specify, as it depends on what initiates the event or oscillation. Switching events or rapid control actions initiated as a result of passing a threshold level in a measured quantity and any time delays in the design of the *plant* should be straightforward to assess. It is recommended that the fallback criterion for this requirement be that:

- the response must be explainable; and
- any inconsistency in the response should lead to an investigation to establish a plausible reason for the inconsistency. A revision to the model should be considered in the latter circumstance.

- (ii) after the first cycle of the oscillatory response, to the upper and lower bounds of the envelope of the oscillatory response.
- (d) Taking into account the level at which *voltage* settles at the *connection point*, the final *active power* or *reactive power* value at which the *plant* would settle is within the more restrictive of:
  - (i) the final value at which the model response settles  $\pm 2\%$  of the plant's maximum capacity; or
  - (ii) the final value at which the model response settles  $\pm 10\%$  of the total change in the quantity following the Disturbance.

Where measurement results can be shown to have been affected by changes in supply source (e.g. the wind strength for a wind turbine), this shall be taken into consideration when assessing this criterion, so long as sufficient evidence can be shown to demonstrate the cause of the input power change, and in the case of large variations, sufficient efforts were made to re-test the plant to obtain improved measurement results.

Note that *plant* closed-loop internal quantities have a reduced accuracy requirement of  $\pm 10\%$  of the change for 90% of the samples within the transient window.

If AEMO and the NSP agree that dynamic changes in the *network* have contributed to model inaccuracy, they may relax one or more of these accuracy requirements. Additionally, further deviations beyond the model accuracy requirements for *plant* internal quantities may be permitted when direct measurement of internal quantities is not practicable or there are known model deficiencies<sup>51</sup>.

#### 165.2.26.2.2 **Balanced and Unbalanced Disturbances**

Positive-sequence simulation models are expected to meet the model accuracy requirements specified in Section 6.2.1 for balanced Disturbances. For comparison of the response to different types of unbalanced faults is more qualitative a positive-sequence model can still be used if it can achieve the required, and the accuracy requirements do not strictly apply<sup>52</sup>.

When a positive-sequence model fails to meet the accuracy requirements by a material margin, the use of EMT-type simulation models or three-phase RMS simulation models are expected to meet the model accuracy requirements for balanced and unbalanced Disturbances. The same will apply to three-phase RMS simulation models is permissible provided that the simulation model chosen can demonstrate compliance with the model accuracy requirements.

#### 165.2.36.2.3 **Stable response for the entire intended operating range**

The model initialisation and operating range should be consistent with the actual equipment design in regard to the following:

- The entire range of *active power*.
- The entire range of *reactive power/power factor* (including limits of *reactive power* generation and consumption).

#### 165.2.46.2.4 **Stable but different response when the response becomes limited**

Models must demonstrate accurate and stable behaviour when the limits implemented within the *plant control systems* are reached. For example, activation of a *synchronous plant* under- or over-excitation limiter should not cause model instability, or produce the same response for a scenario where limiters have not been activated. Output of each limiter must be available for plotting to demonstrate that it acts for intended operating conditions, and do not falsely activate when the limit is not reached.

<sup>51</sup> For example, *synchronous generation* field current.

<sup>52</sup> When using positive-sequence type models for simulation of unbalanced Disturbances, the Applicant must provide information on any possible changes in the model parameters to simulate various types of faults.

### **165.2.56.2.5 Unstable response when operated beyond its intended operating range**

Where *network* conditions, energy source limitations, Disturbances etc. would cause the *plant* to become unstable, activate protection mechanisms, or otherwise cease operation, it is expected that the model would reflect the *plant's* response. Models should not be created such that they continue to operate stably outside of the *plant's* operating envelope<sup>53</sup>.

### **165.2.66.2.6 No unexpected or uncharacteristic responses**

The model must not show characteristics that are not present in the *plant* response, both in terms of the electrical response and modelling numerical artefacts.

## **165.36.3 Model validation and confirmation**

Each model must be developed and tested to the extent reasonably necessary to establish that it will meet the accuracy requirements. To achieve this:

- during the *plant* design and development stages, it is expected that the model will be rigorously derived from design information and its performance is confirmed against the actual plant response; and
- R2 parameters and models must be derived from on-site tests.

Parameters, other than R2, that contribute most significantly to the accuracy of the model for fault, *voltage* and *frequency* Disturbances in the *power system*, must be derived from on-site tests, where possible. Test results from the commissioning tests (used to confirm compliance of the *plant* with *performance standards*) may also provide, or contribute to, R2 data values<sup>54</sup>. These parameters must still be validated (in aggregate) through the validation of the overall performance of the *plant*, *network element*, device, unit or controller to which they pertain.

### **165.3.16.3.1 Model confirmation for plant with limited impact**

Where the new or altered *plant* is expected to have limited foreseeable impact on the surrounding *network* and nearby *plant*, model validation requirements may be relaxed by AEMO and the NSP. This could apply to either the scope of model validation tests or the permissible model accuracy requirements.

Confirmation of model performance would consist of the following (to be provided to the NSP and AEMO):

- Factory test results for:
  - *Generating unit* and energy conversion *plant*;
  - *Control systems*, including the energy conversion plant and electricity output control and regulation *plant* (e.g. exciter, AVR and PSS);
  - *Generating unit transformer*; and
  - The *generating system transformer* (if different from the *generating unit transformers*).
- Comparisons of simulations for step response tests against the on-site step response test results. This would include tests at several load levels and operation across the relative power range, such that:
  - The model response is within the tolerances specified in these Guidelines or tolerances agreed by AEMO and the NSP on a case-by-case basis; and
  - Deviations must be reasonably explained and attributed, for example, to the influences of external parameters or differences in pre-test simulation conditions with actual system conditions.

<sup>53</sup> Models that cease output when exposed to conditions outside the intended operating range are not considered inferior, however, the cessation of the model output must not result in instability or crashing of the underlying simulation tool.

<sup>54</sup> Note that clause S5.2.4(d)(1) of the NER specifies that the R2 values must be submitted to AEMO and the NSP within three months of the completion of commissioning.

**165-3.26.3.2 Pre-connection model confirmation**

Confirmation of RMS- and EMT-type model adequacy prior to detailed *connection* studies is prudent to minimise risks that may multiply the time and effort in assessing a specific *plant connection* and alterations. The following principles will apply to pre-*connection* model confirmation tests:

- Among Disturbances applied for model confirmation tests, there should be a two-phase-ground or three-phase fault equivalent to what might be experienced by a *generating unit* upon installation.
- The post-fault fault level and *network* impedances used for the testing should be reasonably representative of, or lower than, the post-fault fault level that the *plant* would experience.
- The individual item of *plant* tested is identical to the ones to be installed.
- The *plant* tested has identical *control system* settings to the one being installed, or the difference in settings can be translated into appropriate model parameter values applicable to the *plant* to be installed.
- The accuracy and adequacy of EMT-type models must be confirmed against the response of individual items of *plant*, including *generating units* and dynamic *reactive power* support *plant* (if applicable) for the conditions specified above, or against the validated EMT-type models.
- Changes in the *control systems* or settings of individual items of *plant* are necessary if the submitted EMT-type model exhibits uncharacteristic or unexpected responses.
- Model response should be generally aligned with expected response. The model accuracy requirements set out in Section 6.2.1 will not strictly apply during this stage.
- Tests should be conducted across a range of operating conditions including pre-Disturbance *active power* and *reactive power* levels.

[NSPs must provide the range of operating conditions, including pre-Disturbance levels of active power and reactive power for the required tests to be carried out.](#)

Results obtained from off-site tests or factory tests may be used for model confirmation tests. Another approach adopted by power system equipment manufacturers is Hardware in Loop (**HIL**) testing to simulated Disturbances well before *plant* undergoes on-site commissioning and R2 model validation.

**165-3.36.3.3 Post-connection model validation (R2)**

R2 model validation is the final stage of providing evidence that the models submitted to AEMO and the NSP are of adequate quality to be used in *power system* studies to determine how to operate the *power system* securely. It is validated by comparing RMS and EMT model response to the *plant* installed at the site of interest.

For each relevant *performance standard* arising out of the technical requirements in clause S5.2.5 of the NER, Table 5 describes the model validation required from the Applicant for the *plant* in question.

**Table 5 Simulation tools required for R2 model validation**

Clause of the NER	RMS simulation tool	EMT simulation tool	Harmonic analysis tool
S5.2.5.1 – Reactive Power Capability	✓	×	×
S5.2.5.2 – Quality of electricity generated	×	Maybe <sup>A</sup>	✓
S5.2.5.3 – Generating unit response to frequency disturbances	✓	×	×
S5.2.5.4 – Generating system response to voltage disturbances	✓	✓	×
S5.2.5.5 – Generating system response to disturbances following contingency events	✓	✓	×
S5.2.5.6 – Quality of electricity generated and continuous uninterrupted operation	×	✓	×

Clause of the NER	RMS simulation tool	EMT simulation tool	Harmonic analysis tool
S5.2.5.7 – Partial Load Rejection	✓	×	×
S5.2.5.8 – Protection of generating systems from power system disturbances	✓	✓	×
S5.2.5.9 – Protection systems that impact on power system security <sup>B</sup>	-	-	-
S5.2.5.10 – Protection to trip plant for unstable operation <sup>B</sup>	-	-	-
S5.2.5.11 – Frequency control	✓	✓	×
S5.2.5.12 – Impact on network capability	✓	×	×
S5.2.5.13 – Voltage and reactive power control	✓	✓	×
S5.2.5.14 – Active Power Control	✓	✓	×

A. If harmonic analysis tool fails to provide the required accuracy.

B. Cannot be realistically validated by staged R2 tests.

### On-site tests

During commissioning, validation of model performance can be demonstrated by model overlays based on the tests outlined in the R2 test template for *synchronous* machines<sup>55</sup> and *asynchronous generation* technologies<sup>56</sup>, and by continuous monitoring described below. For *network* and reactive support *plant*, relevant tests from these templates can be used to demonstrate model performance.

### Continuous monitoring of disturbances

Congruence between *plant* and model dynamic responses for some aspects may be difficult to demonstrate until a *network* Disturbance occurs. It is, therefore, necessary that the Applicant develops a continuous monitoring program to demonstrate model accuracy for all major items comprising the *plant* (i.e. both at a *generating system* and *generating unit* level). As part of the compliance program developed in accordance with clause 4.15 of the NER<sup>57</sup>, high speed data collected during a Disturbance can be overlaid to demonstrate correct model responses. The Applicant must submit the model overlays to the NSP and AEMO for analysis and model verification as soon as possible following such a Disturbance.

## 165.46.4 Non-conformance with model accuracy requirements

Where AEMO or NSP determines that model inaccuracy outside the tolerances specified in Section 6.2.1 manifests itself into a risk to *power system security*, adverse impact on the performance of *Network Users*, or inability meet its *performance standards*, the following action may be required by either the NSP or AEMO:

- additional testing;
- operational constraints imposed until the modelling issue can be resolved;
- revised models or parameters verified by pre-commissioning model confirmation tests be submitted and accepted (revision may result in submission of a detailed vendor-specific model); or
- any combination of these.

These requirements may persist or be repeated until the model accurately reflects the *plant's* response, and hence the *plant's* performance can be adequately predicted by *power system* studies.

<sup>55</sup> Available at: [https://www.aemo.com.au/-/media/Files/Electricity/NEM/Network\\_Connections/Transmission-and-Distribution/Generating-System-Test-Plan-Template-for-Conventional-Synchronous-Machines.pdf](https://www.aemo.com.au/-/media/Files/Electricity/NEM/Network_Connections/Transmission-and-Distribution/Generating-System-Test-Plan-Template-for-Conventional-Synchronous-Machines.pdf)

<sup>56</sup> Available at: [https://www.aemo.com.au/-/media/Files/Electricity/NEM/Network\\_Connections/Transmission-and-Distribution/Generating-System-Test-Plan-Template-for-Non-Synchronous-Generation.pdf](https://www.aemo.com.au/-/media/Files/Electricity/NEM/Network_Connections/Transmission-and-Distribution/Generating-System-Test-Plan-Template-for-Non-Synchronous-Generation.pdf)

<sup>57</sup> A compliance program instituted and maintained under clause 4.15(b) must ... provide reasonable assurance of ongoing compliance with each applicable *performance standard*.



## **166.7. CONFIDENTIALITY OF INFORMATION AND MODELS PROVIDED**

### **166.17.1 Storage and use by AEMO**

AEMO's personnel have restricted access to data provided to AEMO by *Registered Participants* under the NER on a need-to-know basis.

Information obtained by AEMO under clause S5.4.2 of the NER is stored by AEMO on its systems, while the models so obtained are stored in AEMO's OPDMS for planning, operations, DSA and other applications. All information and models are used for the purpose for which they are intended to be used, consistent with the NER.

### **166.27.2 Intellectual property**

These Guidelines do not affect the intellectual property rights in the information and models obtained by AEMO under clause S5.4.2 of the NER.

## **7.3 EMT model black-boxing, compilation or encryption**

As models can be provided to *Registered Participants* under the NER, model owners may wish to black-box, compile or otherwise encrypt portions of an EMT model that are commercially sensitive, or where additional intellectual property protection is desired.

Provided the requirements in these Guidelines as to the model's utility are met, and a legitimate user of the model is not hampered in their ability to carry out legitimate studies using the model, black-boxing is acceptable.

Model owners remain responsible for the adequacy of the black-boxing, compilation or other encryption of their model.

## **166.37.4 Provision of information and models to third parties**

### **166.3.17.4.1 Generally**

Requests for models and other information must be directed to AEMO under clause 3.13.3(k) of the NER. As the responsible party for the dissemination of models and other information under clause 3.13.3(l) ~~of the NER~~, AEMO will manage the dissemination of models and other information held by AEMO in accordance with the NER and will only disseminate it to the extent it is necessary for the purpose for which it is requested by a *Registered Participant*.

Clause 3.13.3(l) requires AEMO to provide information that is reasonably required by a *Registered Participant* to carry out *power system* studies (including load flow and dynamic simulations) for planning and operational purposes and only some of that information must be treated as *confidential information*, notably information related to the model source code<sup>58</sup> and *power system* and *generating system* model information provided to a TNSP for planning and operational purposes<sup>59</sup>.

AEMO will update and *publish* the register it is required to maintain under clause 3.13.3(p1) to include the fulfilment of all new requests for models and other information.

~~AEMO will never provide the entire network model to a *Registered Participant*, only a model of those parts of the network the *Registered Participant* requires and will only ever provide sufficient data and information related to plant or a model to enable the *Registered Participant* to carry out the studies for which the data and information has been requested and to which the *Registered Participant* is entitled under the NER.~~ Table 6 summarises the type of model that AEMO will provide to a *Registered Participant* depending on the nature of the request.

<sup>58</sup> See clause 3.13.3(l)(3).

<sup>59</sup> See clause 3.13.3(l7).



**Table 6 Models to be provided by AEMO**

Data Requests	Application	
	System Strength Impact Assessment	Other Power System Studies
Generator data (section 79.3.2)	Not applicable	RMS (full)
Generator and MNSP data (section 79.3.3)	EMT (limited) <sup>1</sup>	RMS (full)
NSP data (section 79.3.4)	EMT full	RMS (full) & EMT full

<sup>1</sup> 'Limited' means that the contents of the model will be limited to those strictly necessary for the performance of a full *system strength impact assessment*, or whether the model was reasonably appropriate for conducting the full *system strength impact assessment*, as appropriate.

**7.4.2 Reasonably required information**

[Clause 3.13.3\(k2\) requires AEMO to set out the circumstances in which the information required under clause 3.13.3\(k\)\(2\) to be 'reasonably required' by a Registered Participant. The information referred to in clause 3.13.3\(k\)\(2\) is information to carry out power system studies \(including load flow and dynamic simulations\) for planning and operational purposes.](#)

[The remainder of this section 7.3.2 details what AEMO considers to be 'reasonably required':](#)

**Generators**

The information required to be provided under clause 3.13.3(l) and (l5) in respect of a *generating system* is limited to that which AEMO holds and includes:

- The RUG, in unaltered form<sup>60</sup>.
- Model source code, subject to the restrictions in clause 3.13.3(l)(2) and (l4), and permissions in clause 3.13.3(l3).
- Model information reasonably required by a TNSP for planning and operational purposes, subject to the requirements in clause 3.13.3(l6).

~~Any model provided under clause 3.13.3(l) and (l5) remains confidential information and can only be used by the recipient for the purpose permitted by clause 3.13.3(k).~~

**Generators and Market Network Service Providers affected by a System Strength Impact Assessment**

As stipulated by clause 4.6.6(e) of the NER, where *plant* is subject to a full *system strength impact assessment*, AEMO is required to treat a request for the 'model' referred to in clause 4.6.6(b)(2) as a request under clause 3.13.3(k)(2) and provide the model to:

- The NSP required to carry out the full *system strength impact assessment*.
- Where only one Applicant is impacted by the *system strength impact assessment*, to that Applicant.
- Where more than one Applicant is affected by the *system strength impact assessment* and, provided the NSP required to carry out the *system strength impact assessment* has complied with section 4.2.3 of the *system strength assessment guidelines*, all affected Applicants to the extent that the impact of neighbouring *plant* ([existing or proposed](#)) needs to be accounted for in any new or altered *plant* design.

~~Any model provided under clause 4.6.6(e) remains confidential information and can only be used by the recipient to:~~

- ~~• In the case of the NSP, carry out the full *system strength impact assessment*.~~
- ~~• In the case of an Applicant, assess whether the model was reasonably appropriate for conducting the *system strength impact assessment*.~~

<sup>60</sup> See clause 3.13.3(l)(1).



## Network Service Providers

The information required to be provided under clause 3.13.3(l) and (l5) in respect of a *network* or any *network element* is limited to that which AEMO holds and includes:

- Model source code, subject to the restrictions in clause 3.13.3(l)(2) and (l6), and permissions in clause 3.13.3(l3).
- As specified in clause 3.13.3(l3), historical information, *network* dynamic model parameter values, a *network* model of the *national grid* suitable for load flow and fault studies, and other technical data listed in Schedules 5.5.3 and 5.5.4.

~~Any model provided under clause 3.13.3(l) and (l5) remains confidential information and can only be used by the recipient for the purpose permitted by clause 3.13.3(k).~~

### 7.4.3 Confidentiality

#### Generators

~~Any model provided under clause 3.13.3(l) and (l5) remains confidential information and can only be used by the recipient for the purpose permitted by clause 3.13.3(k).~~

#### Generators and Market Network Service Providers affected by a System Strength Impact Assessment

~~Any model provided under clause 4.6.6(e) remains confidential information and can only be used by the recipient to:~~

- ~~In the case of the NSP, carry out the full *system strength impact assessment*.~~
- ~~In the case of an Applicant, assess whether the model was reasonably appropriate for conducting the *system strength impact assessment*.~~

#### Network Service Providers

~~Any model provided under clause 3.13.3(l) and (l5) remains confidential information and can only be used by the recipient for the purpose permitted by clause 3.13.3(k).~~

## 167.8. ALTERNATIVE PROCESS

Section 8 describes, where an Applicant cannot provide the required information or model, a process to be followed to give AEMO and the connecting NSP sufficient information to be able to fulfil the purpose for which the information or model is required.

### 167.18.1 Generally

Applicants may apply for a variation to a requirement to provide specified data or models required by these Guidelines using the form contained in Appendix B.

## 8.2 Examples of Requests

To assist *Registered Participants*, AEMO provides the following examples of cases where an application to vary a requirement under these Guidelines might be appropriate:

- Representation of pump storage and *generation* in the one model.
- Provision of model source code based on C or C++, rather than Fortran.

### 167.28.3 Consideration of Request

AEMO must consider a request received in the form contained in Appendix B by reference to the following matters:

- the reasonable costs of efficient compliance by Applicants with these Guidelines and the Data Sheets compared to the likely benefits from the use of the information provided under those;



- whether the information has been made available to AEMO in the past;
- NSPs' requirements for data and modelling information that is reasonably necessary for them to fulfil their obligations under the NER or jurisdictional electricity legislation;
- the model, and how it should be used;
- the potential impact of the *plant* to be *connected* on *power system security*;
- quality of supply to *Network Users*;
- the calculation of *network* limits;
- the extent to which changes are expected to affect the operation of the *connection* under consideration;
- the ability for an NSP, AEMO, the Applicant, or any other party allowed under the NER to conduct studies for *connection applications* and access negotiations; and
- any other matters AEMO considers to be reasonably relevant to a request.

#### **167.38.4 Determination**

Following consideration of the request, AEMO must:

- accept or reject it;
- propose options for the Applicant to consider; or
- request further information.



## APPENDIX A. APPLICATION FOR EXEMPTION FROM THE REQUIREMENT TO PROVIDE MODEL AND OTHER INFORMATION

### APPLICATION FOR EXEMPTION FROM THE REQUIREMENT TO PROVIDE INFORMATION OR MODELS SPECIFIED IN THE POWER SYSTEM MODEL GUIDELINES

To enable a timely response to your Application please complete all sections of this form. Please use additional pages and attach supporting documentation where required.

<b>Applicant name</b>	
Contact Details	
Name	
Phone	
Email	
Postal Address	
Date of Application	
<b>Affected Plant</b>	
<b>Size of Plant</b>	
Why Applicant should be granted an Exemption (based on the grounds detailed in section 3.3 of the Power System Model Guidelines).	
Any other relevant information	

Please send this application to: [connections@aemo.com.au](mailto:connections@aemo.com.au)



## APPENDIX B. APPLICATION TO PROVIDE ALTERNATIVE MODEL OR INFORMATION

### APPLICATION TO PROVIDE ALTERNATIVE MODEL OR INFORMATION SPECIFIED IN THE POWER SYSTEM MODEL GUIDELINES

To enable a timely response to your Application please complete all sections of this form. Please use additional pages and attach supporting documentation where required.

<b>Applicant name</b>	
Contact Details	
Name	
Phone	
Email	
Postal Address	
Date of Application	
Information or model requirement that cannot be met	
Include reference to section in the Guidelines where the requirement is specified.	
Why the requirement cannot be met.	
<p>Include:</p> <ul style="list-style-type: none"> <li>evidence to substantiate reasons for being unable to meet the requirement;</li> <li>consideration of how this might affect AEMO or NSP's ability to assess proposed <i>access standards</i>; and</li> <li>discussion of alternative options considered, sufficient to satisfy the NSP and AEMO that meeting the requirement is technically unachievable.</li> </ul>	
Proposed Alternative Information or Model to be provided	
Include a description of the discrepancy between the relevant requirement and what is proposed to be provided and a discussion of how the alternative is a reasonable equivalent of the requirement that cannot be met.	
Proposed date by which Alternative Information or Model will be provided	

Please send this application to: [connections@aemo.com.au](mailto:connections@aemo.com.au)

## APPENDIX C. MODELLING COMPONENT REQUIREMENTS

Appendix C sets out components that are required to be included in models based on the *plant*, studies being completed and the tool being used. These tables focus on physical components to be included within models. As load flow and fault level studies are based on Newtonian solution methods, these study types are excluded from all tables in this appendix.

### C.1 Definitions and notes

#### C.1.1 Protection systems

Experience has shown that protective functions of *plant* can have a major impact on stability of the *generating system* and the *power system*. Reference to “protection” in the following table and footnotes includes, [but is not limited to](#):

- High and low *voltage* protection;
- Over- and under-*frequency* protection;
- Rate of change of *frequency* protection;
- Multiple fault ride-through protection;
- Loss of excitation protection;
- Over-flux (V/Hz) protection;
- Out-of-step protection;
- Negative phase sequence (voltage unbalance) protection;
- Reverse *active power* protection;
- Torsional stress protection; [and](#)
- Unit *transformer* and generator differential protection.

**All protection systems included in the models must be consistent with the *plant's* performance standard.**

#### C.1.2 Control loops

The representation of control loops in converter-connected technology is of particular importance for assessing transient stability of *plant*. Where the following terms are included within tables, the sub-points indicate the control loops that are expected to be represented within the model.

### Outer loop converter control

- Active power and reactive power control;
- Active torsional damping (if applicable);
- Fast acting *voltage* control (if applicable);
- Fast acting *frequency* control (if applicable).

### Inner control loop

- DC link current control;
- DC link *voltage* control;
- Rotor-side current control (if applicable).

### C.1.3 High-frequency transient models

Only plant involved in power system restoration, including SRAS sources, are required to provide high-frequency transient models. These models must represent fast- and slow-front transients as defined by the IEC Standard 60071 Part 1.

## C.2 Wind generation

- Models to be aggregated as per Section 4.7.
- Measurements feeding into controls must include relevant filtering and delays.
- Winding Details-ratios of VTs and CTs feeding protection mechanisms must be provided.

### C.2.1 Turbine model components

Elements marked with an asterisk (\*) require the Applicant to determine whether the component needs to be included to accurately represent the plant response for the phenomena of interest.

Component	Aerodynamics	Pitch controller	Mechanical drive train	Torsional damping	Electrical generator <sup>A</sup>	Dynamic braking resistor / chopper	DC link	IGBT switches and PWM switching	Unit transformer <sup>B</sup>
<b>Study</b>									
<b>Transient stability</b>	RMS*, EMT*	RMS*, EMT*	RMS*, EMT*	RMS, EMT	RMS, EMT	RMS, EMT	RMS, EMT	-	RMS, EMT
<b>Sub-synchronous interactions</b>	EMT*	EMT*	EMT	EMT	EMT	EMT	EMT	-	EMT

Component \ Study	Aerodynamics	Pitch controller	Mechanical drive train	Torsional damping	Electrical generator <sup>A</sup>	Dynamic braking resistor / chopper	DC link	IGBT switches and PWM switching	Unit transformer <sup>B</sup>
Switching and lightning High-frequency transient	-	-	-	-	EMT	-	EMT*	EMT	EMT
Harmonics	EMT*	EMT*	EMT*	EMT	EMT	EMT	EMT	EMT	EMT

A. Fifth-order generator.

B. Including saturation for EMT models. For RMS models it is acceptable to represent three-winding *transformers* as two-winding equivalents.

Component \ Study	Internal filters	Inner loop converter control	Outer loop converter control	Phase locked loop <sup>A</sup>	Frequency control <sup>B</sup>	High voltage ride-through	Low voltage ride-through	Multiple fault ride-through limitations	Protection
Transient Stability	RMS, EMT	EMT	RMS, EMT	EMT	RMS, EMT	RMS, EMT	RMS, EMT	RMS, EMT	RMS, EMT
Sub-synchronous interactions	EMT	EMT	EMT	EMT	EMT	EMT	EMT	EMT	EMT
High-frequency transient Switching and lightning	EMT	EMT*	EMT*	EMT*	-	EMT	-	-	EMT
Harmonics	EMT	EMT	EMT	EMT	EMT	-	-	-	-

A. Explicit representation.

B. Including *frequency* raise and lower, *frequency* droop and deadbands.

### C.2.2 Balance of plant model components

Component \ Study	Park controller <sup>A</sup>	Other coordinated control systems	Reticulation Network	Static reactive support plant <sup>B</sup>	Dynamic reactive support plant <sup>C</sup>	Connection point transformers <sup>D</sup>	Transformer onload tap changer controllers
Transient Stability	RMS, EMT	RMS, EMT	RMS, EMT	RMS, EMT	RMS, EMT	RMS, EMT	RMS, EMT
Sub-synchronous interactions	EMT	EMT	EMT	EMT	EMT	EMT	-



Component Study	Park controller <sup>A</sup>	Other coordinated control systems	Reticulation Network	Static reactive support plant <sup>B</sup>	Dynamic reactive support plant <sup>C</sup>	Connection point transformers <sup>D</sup>	Transformer onload tap changer controllers
High-frequency transient switching and lightning	-	-	EMT	EMT	EMT	EMT	-
Harmonics	EMT*	EMT*	EMT	EMT	EMT	EMT	-

A. Including delays that affect performance, controls and outputs for *reactive power* support plant, controls for *active power*, *reactive power*, *voltage*, *power factor* and *frequency*, and any participation in fault ride-through protection.

B. Details of switching philosophy to be provided in the RUG.

C. Including full *voltage* controller representation and relevant protection mechanisms.

D. Including saturation for EMT models. For RMS models it is acceptable to represent three-winding *transformers* as two-winding equivalents.

### C.3 Photovoltaic generation

- Models to be aggregated as per Section 4.7.
- Measurements feeding into controls must include relevant filtering and delays.
- Winding Details-ratios of VTs and CTs feeding protection mechanisms must be provided.

#### C.3.1 Inverter model components

Elements marked with an asterisk (\*) require the Applicant to determine whether the component needs to be included to accurately represent the plant response for the phenomena of interest.

Component Study	Solar Cells	DC-DC converter	DC link	IGBT switches	PWM switching	Unit transformer <sup>A</sup>	Internal filters
Transient Stability	EMT*	RMS, EMT	RMS, EMT	-	-	RMS, EMT	RMS, EMT
Sub-synchronous interactions	-	EMT	EMT	-	-	EMT	EMT
High-frequency transient switching and lightning	-	EMT*	EMT*	EMT	EMT	EMT	EMT
Harmonics	-	EMT	EMT	EMT	EMT	EMT	EMT

A. Including saturation for EMT models. For RMS models it is acceptable to represent three-winding transformers as two-winding equivalents.

Component Study	Inner loop converter control	Outer loop converter control	Phase locked loop <sup>A</sup>	Frequency control <sup>B</sup>	High voltage ride-through	Low voltage ride-through	Multiple fault ride-through limitations	Protection
Transient Stability	EMT	RMS, EMT	EMT	RMS, EMT	RMS, EMT	RMS, EMT	RMS, EMT	RMS, EMT
Sub-synchronous interactions	EMT	EMT	EMT	EMT	EMT	EMT	-	EMT
High-frequency transient switching and lightning	EMT*	EMT*	EMT*	-	EMT	-	-	EMT
Harmonics	EMT	EMT	EMT	EMT	-	-	-	-

A. Explicit representation.

B. Including *frequency* raise and lower, *frequency* droop and deadbands.

### C.3.2 Balance of plant model components

Component Study	Park controller <sup>A</sup>	Other coordinated control systems	Reticulation network	Static reactive support plant <sup>B</sup>	Dynamic reactive support plant <sup>C</sup>	Connection point transformers <sup>D</sup>	Transformer onload tap changer controllers
Transient Stability	RMS, EMT	RMS, EMT	RMS, EMT	RMS, EMT	RMS, EMT	RMS, EMT	RMS, EMT
Sub-synchronous interactions	EMT	EMT	EMT	EMT	EMT	EMT	-
High-frequency transient switching and lightning	-	-	EMT	EMT	EMT	EMT	-
Harmonics	EMT*	EMT*	EMT	EMT	EMT	EMT	-

A. Including delays that affect performance, controls and outputs for *reactive power* support plant, controls for *active power*, *reactive power*, *voltage*, *power factor* and *frequency*, and any participation in fault ride-through protection.

B. Details of switching philosophy to be provided in the RUG.

C. Including full *voltage* controller representation and relevant protection mechanisms.

D. Including saturation for EMT models. For RMS models it is acceptable to represent three-winding *transformers* as two-winding equivalents.

### C.4 Converter-based energy storage systems

- Models to be aggregated as per Section 4.7.
- Measurements feeding into controls must include relevant filtering and delays.
- Details Winding ratios of VTs and CTs feeding protection mechanisms must be provided.

### C.4.1 Converter model components

Elements marked with an asterisk (\*) require the Applicant to determine whether the component needs to be included to accurately represent the plant response for the phenomena of interest.

Component \ Study	Energy storage (battery, super-capacitor)	DC-DC converter	DC link	IGBT switches	PWM switching	Unit transformer <sup>A</sup>	Internal filters
Transient Stability	EMT*	RMS, EMT	RMS, EMT	-	-	RMS, EMT	RMS, EMT
Sub-synchronous interactions	-	EMT	EMT	-	-	EMT	EMT
High-frequency transient switching and lightning	-	EMT*	EMT*	EMT	EMT	EMT	EMT
Harmonics	-	EMT	EMT	EMT	EMT	EMT	EMT

A. Including saturation for EMT models. For RMS models it is acceptable to represent three-winding transformers as two-winding equivalents.

Component \ Study	Inner loop converter control	Outer loop converter control	Phase locked loop <sup>A</sup>	Frequency control <sup>B</sup>	High voltage ride-through	Low voltage ride-through	Multiple fault ride-through limitations	Protection
Transient Stability	EMT	RMS, EMT	EMT	RMS, EMT	RMS, EMT	RMS, EMT	RMS, EMT	RMS, EMT
Sub-synchronous interactions	EMT	EMT	EMT	EMT	EMT	EMT	-	EMT
High-frequency transient switching and lightning	EMT*	EMT*	EMT*	-	EMT	-	-	EMT
Harmonics	EMT	EMT	EMT	EMT	-	-	-	-

A. Explicit representation.

B. Including *frequency* raise and lower, *frequency* droop and deadbands.

### C.4.2 Balance of plant model components

Component \ Study	Park controller <sup>A</sup>	Other coordinated control systems	Reticulation network	Static reactive support plant <sup>B</sup>	Dynamic reactive support plant <sup>C</sup>	Connection point transformers <sup>D</sup>	Transformer onload tap changer controllers
Transient Stability	RMS, EMT	RMS, EMT	RMS, EMT	RMS, EMT	RMS, EMT	RMS, EMT	RMS, EMT

Component Study	Park controller <sup>A</sup>	Other coordinated control systems	Reticulation network	Static reactive support plant <sup>B</sup>	Dynamic reactive support plant <sup>C</sup>	Connection point transformers <sup>D</sup>	Transformer onload tap changer controllers
Sub-synchronous interactions	EMT	EMT	EMT	EMT	EMT	EMT	-
High-frequency transient (Switching and lightning)	-	-	EMT	EMT	EMT	EMT	-
Harmonics	EMT*	EMT*	EMT	EMT	EMT	EMT	-

A. Including delays that affect performance, controls and outputs for *reactive power* support plant, controls for *active power*, *reactive power*, *voltage*, *power factor* and *frequency*, and any participation in fault ride-through protection.

B. Details of switching philosophy to be provided in the RUG.

C. Including full *voltage* controller representation and relevant protection mechanisms.

D. Including saturation for EMT models. For RMS models it is acceptable to represent three-winding *transformers* as two-winding equivalents.

## C.5 High voltage DC link

- Measurements feeding into controls must include relevant filtering and delays.
- Details-Winding ratios of VTs and CTs feeding protection mechanisms must be provided.

### C.5.1 Inverter/rectifier model components

Elements marked with an asterisk (\*) require the Applicant to determine whether the component needs to be included to accurately represent the plant response for the phenomena of interest.

Component Study	HVDC cable/line	IGBT switches / thyristors	PWM switching / firing pulses	AC and DC filters	Link transformer <sup>A</sup>	Static reactive support plant <sup>B</sup>	Dynamic reactive support plant <sup>C</sup>	Transformer onload tap changer controllers
Transient Stability	RMS, EMT	EMT	EMT	RMS, EMT	RMS, EMT	RMS, EMT	RMS, EMT	RMS, EMT
Sub-synchronous interactions	EMT	-	-	EMT	EMT	EMT	EMT	-
High-frequency transient (Switching and lightning)	EMT	EMT*	EMT*	EMT	EMT	EMT	EMT	-
Harmonics	EMT	EMT	EMT	EMT	EMT	EMT	EMT	-

A. Including saturation for EMT models.

B. Details of switching philosophy to be provided in the RUG.

C. Including full *voltage* controller representation and relevant protection mechanisms.

Component Study	Inner loop converter control (if applicable)	Outer loop converter control	Phase locked loop <sup>A</sup>	Frequency control <sup>B</sup>	High voltage ride-through	Low voltage ride-through	Other coordinated control systems	Multiple fault ride-through limitations	Protection
<b>Transient Stability</b>	EMT	RMS, EMT	EMT	RMS, EMT	RMS, EMT	RMS, EMT	RMS, EMT	RMS, EMT	RMS, EMT
<b>Sub-synchronous interactions</b>	EMT	EMT	EMT	EMT	EMT	EMT	EMT	-	EMT
<b>High-frequency transient switching and lightning</b>	EMT*	EMT*	EMT*	-	EMT	-	-	-	EMT
<b>Harmonics</b>	EMT	EMT	EMT	EMT	-	-	EMT*	-	-

A. Explicit representation.

B. Including *frequency* raise and lower, *frequency* droop and deadbands.

## C.6 Synchronous machines and generators

- Measurements feeding into controls must include relevant filtering and delays.
- Details-Winding ratios of VTs and CTs feeding protection mechanisms must be provided.

### C.6.1 Generator model components

Elements marked with an asterisk (\*) require the Applicant to determine whether the component needs to be included to accurately represent the plant response for the phenomena of interest.

Component Study	Generator <sup>A</sup>	Mechanical drive train	Torsional damping	Turbine, flywheel	Governor <sup>B</sup>	Power system stabiliser	Unit transformer <sup>C</sup>	Exciter	Automatic voltage regulator <sup>D</sup>
<b>Transient Stability</b>	RMS, EMT	EMT*	EMT*	RMS, EMT	RMS, EMT	RMS, EMT	RMS, EMT	RMS, EMT	RMS, EMT
<b>Sub-synchronous interactions</b>	EMT	EMT	EMT	EMT	EMT	EMT	EMT	EMT	EMT
<b>High-frequency transient switching and lightning</b>	EMT	-	-	EMT	EMT	EMT	EMT	EMT	EMT
<b>Harmonics</b>	EMT	-	-	-	-	-	EMT	EMT	EMT

A. Full saturation curve required for EMT models.

B. Including *frequency* control, droop, deadbands and isochronous mode.

C. Including saturation characteristics for EMT models.

D. Including compensator and derived measurements.

Component Study	Excitation limiters <sup>E</sup>	Transformer on-load tap changer controllers	Multiple fault ride-through limitations	Protection
Transient Stability	RMS, EMT	RMS, EMT	RMS, EMT	RMS, EMT
Sub-synchronous interactions	EMT	-	-	EMT
High-frequency transient switching and lightning	EMT	-	-	EMT
Harmonics	EMT	-	-	-

E. Including all applicable limiters in over- and under-excited range (e.g over-excitation limiter, under-excitation limiter, V/Hz limiter, PQ limiters etc.).

## C.7 Converter-based reactive support systems

Including SVCs, STATCOMs, etc.

- Measurements feeding into controls must include relevant filtering and delays.
- Details-Winding ratios of VTs and CTs feeding protection mechanisms must be provided.

### C.7.1 Reactive support model components

Elements marked with an asterisk (\*) require the Applicant to determine whether the component needs to be included to accurately represent the plant response for the phenomena of interest.

Component Study	DC link componentry	Thyristor / IGBT switches	PWM switching / firing control	Unit transformer <sup>A</sup>	Internal filters	External shunt devices and filters <sup>B</sup>
Transient Stability	EMT*	-	-	RMS, EMT	RMS, EMT	RMS, EMT
Sub-synchronous interactions	-	-	-	EMT	EMT	EMT
High-frequency transient switching and lightning	-	EMT	EMT	EMT	EMT	EMT
Harmonics	-	EMT	EMT	EMT	EMT	EMT

A. Including saturation for EMT models. For RMS models it is acceptable to represent three-winding transformers as two-winding equivalents.

B. Including any control of external shunts from plant controller.

Component Study	Inner loop converter control	Outer loop converter control	Phase locked loop <sup>A</sup>	Frequency control <sup>B</sup>	Power oscillation damping control	High voltage ride-through	Low voltage ride-through	Multiple fault ride-through limitations	Protection
<b>Transient Stability</b>	EMT	RMS, EMT	EMT	RMS, EMT	RMS, EMT	RMS, EMT	RMS, EMT	RMS, EMT	RMS, EMT
<b>Sub-synchronous interactions</b>	EMT	EMT	EMT	EMT	EMT	EMT	EMT	-	EMT
<b>High-frequency transient switching and lightning</b>	EMT*	EMT*	EMT*	-	EMT	EMT	-	-	EMT
<b>Harmonics</b>	EMT	EMT	EMT	EMT	EMT	-	-	-	-

A. Explicit representation.

B. Including *frequency raise* and *lower*, *frequency droop* and *deadbands*.

## APPENDIX D. QUANTITIES TO BE ASSESSED FOR TRANSIENT AND VOLTAGE ANALYSIS

The following table outlines the quantities that have the accuracy requirements of Section 6.2 applied, based on the test or Disturbance of interest. Quantities that are not applicable to the *plant* under consideration should be ignored (e.g. field *voltage* for a photovoltaic inverter).

Accuracy of EMT model responses are evaluated on their simulation-tool calculated RMS quantities, with filtering appropriate for a 50 Hz nominal system.

Test / Disturbance	Perturbed quantity	Measured quantity	
Voltage Reference Step Power Factor Reference Step Reactive Power Reference Step Active Power Reference Step External Voltage Step	Voltage reference (generating unit or centralised controller)	Plant terminal active power	
		Plant terminal reactive power	
	Power factor reference (generating unit or centralised controller)	Connection point active power	
		Connection point reactive power	
	Reactive power reference (generating unit or centralised controller)	Centralised controller dispatch P <sub>ref</sub>	
		Centralised controller dispatch Q <sub>ref</sub>	
	Active Power Reference Step	Switched shunt, transformer tap, or other external voltage change	Field voltage
			Field current (EMT only)
			Relevant limiter output
			Stabiliser output
			AVR output
			Stator voltage
			Plant terminal voltage
			Connection point voltage
External Voltage Step	Wind speed or solar irradiance	Centralised controller dispatch V <sub>ref</sub>	
		Plant terminal active power	
		Plant terminal reactive power	
		Connection point active power	
		Connection point reactive power	
		Centralised controller dispatch P <sub>ref</sub>	
		Centralised controller dispatch Q <sub>ref</sub>	
		Plant terminal voltage	
		Connection point voltage	
		Centralised controller dispatch V <sub>ref</sub>	



Test / Disturbance	Perturbed quantity	Measured quantity
External Voltage Angle Step	Voltage angle	Plant terminal active power
		Plant terminal reactive power
		Point of Connection active power
		Point of Connection reactive power
		Centralised controller dispatch Pref
		Centralised controller dispatch Qref
		Field voltage
		Field current (EMT only)
		Rotor Angle
		Stabiliser output
		Stator voltage
		Plant terminal voltage
		Point of Connection voltage
		Centralised controller dispatch Vref
Voltage Disturbance	Connection point voltage (network fault)	Plant terminal active power
		Plant terminal reactive power
		Point of Connection active power
		Point of Connection reactive power
		Centralised controller dispatch Pref
		Centralised controller dispatch Qref
		Field voltage
		Field current (EMT only)
		Rotor Angle
		Stabiliser output
		Stator voltage
		Relevant limiter output
		AVR output
		Plant terminal voltage
		Point of Connection voltage
Centralised controller dispatch Vref		
		Plant terminal active power



Test / Disturbance	Perturbed quantity	Measured quantity
<b>Frequency Disturbance</b> <b>External Frequency change</b>	Connection point frequency (network event)	Centralised controller dispatch Pref
		Stabiliser output
	Unit or centralised controller frequency bias injection	AVR output
		Governor control output
		Governor valve position
		Relevant limiter output

## APPENDIX E. TRANSIENT WINDOW DEFINITIONS

The transient window definition is based on the model response, as the model will likely return to a clear Steady State, while due to natural network fluctuations the Steady State of the *plant's* measured response may be more difficult to discern.

Due to the inherently varied nature of transient responses, the following are provided as a guide only.

### E.1 Transient window for an uncontrolled change

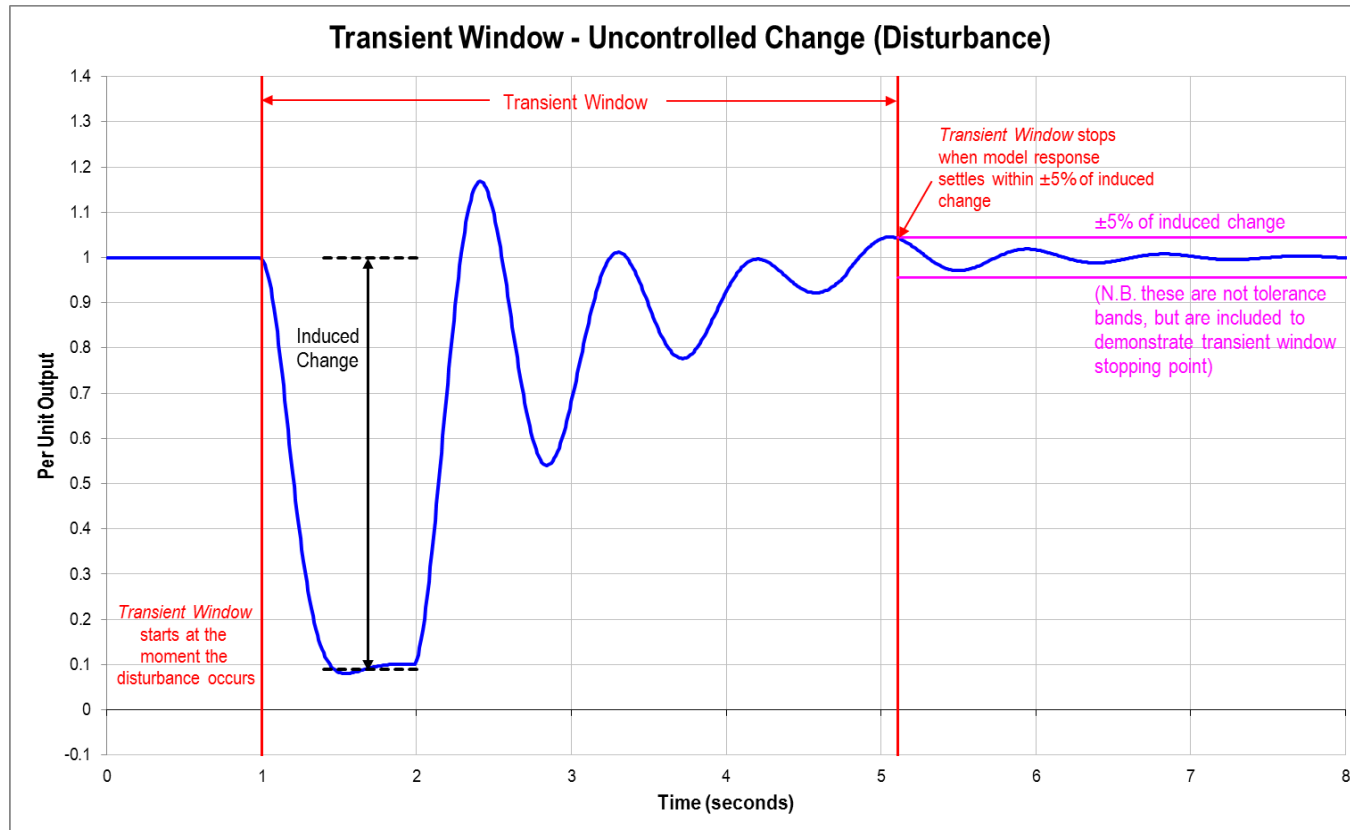

## E.2 Transient window for a controlled change

