

2023 Transmission Expansion Options Report

August 2023

For the Integrated System Plan (ISP)





Important notice

Purpose

AEMO publishes this *2023 Transmission Expansion Options Report* as part of an initiative to improve the accuracy and transparency of transmission expansion options used for the *Integrated System Plan*. This report supplements the *2023 Inputs, Assumptions and Scenarios Report (IASR)*.

This publication is generally based on information available to AEMO as at July 2023 unless otherwise indicated.

Disclaimer

This document or the information in it may be subsequently updated or amended. This document does not constitute legal or business advice, and should not be relied on as a substitute for obtaining detailed advice about the National Electricity Law, the National Electricity Rules, or any other applicable laws, procedures or policies. AEMO has made every effort to ensure the quality of the information in this document but cannot guarantee its accuracy or completeness.

Accordingly, to the maximum extent permitted by law, AEMO and its officers, employees and consultants involved in the preparation of this document:

- make no representation or warranty, express or implied, as to the currency, accuracy, reliability or completeness of the information in this document; and
- are not liable (whether by reason of negligence or otherwise) for any statements or representations in this document, or any omissions from it, or for any use or reliance on the information in it.

Copyright

© 2023 Australian Energy Market Operator Limited. The material in this publication may be used in accordance with the [copyright permissions on AEMO's website](#).

Version control

Version	Release date	Changes
1.0	28/7/2023	Initial release.
1.1	09/08/2023	Updated SQ-CQ Option 5 cost estimate and new easement length to correct scope estimate for new lines. Q2 Option 1 scope change to remove inclusion of Guybal Munjan substation. SNSW-CNSW Option 1 (HumeLink) cost estimate class correction based on information from Transgrid. South West Victoria REZ Expansion preparatory activity cost estimate class correction based on information from AEMO Victorian Planning. Other minor edits.

Executive summary

Transmission expansion needs to be explored to ensure consumers have efficient access to renewable energy and firming resources

The *Integrated System Plan (ISP)* supports Australia's complex and rapid energy transformation towards net zero emissions, identifying development which will enable low-cost firming renewable energy along with net beneficial transmission to provide consumers in the National Electricity Market (NEM) with reliable, secure, affordable and sustainable power.

Transmission network expansion is a key part of the assessment, as it will increase the transfer capacity of renewable energy zones (REZs) and the backbone of the interconnected network, thereby delivering the transition at lower cost to consumers.

The 2023 *Transmission Expansion Options Report* outlines transmission expansion options to inform the development of the 2024 ISP. AEMO, transmission network service providers (TNSPs) and jurisdictional bodies have undertaken extensive collaboration and joint planning to inform the preparation of this report. This report is also the result of extensive stakeholder engagement, and AEMO sincerely thanks all stakeholders who engaged in consultation on this report.

This report includes:

- **AEMO's approach to forecasting transmission costs**, including trajectories for the individual components that make up estimates for transmission network infrastructure.
- **Transmission expansion options** to be evaluated in the 2024 ISP, including conceptual design, lead time, location and cost estimate.
- **Calculation of approximate generation connection costs** applied within each REZ.
- **An update to AEMO's Transmission Cost Database**, undertaken by independent consultant Mott MacDonald to reflect the most recent cost estimation processes and data for transmission network assets.

A **consultation summary report has been released** alongside this report, providing AEMO's responses to feedback received on the Draft 2023 *Transmission Expansion Options Report*.

Cost estimates have been updated to reflect supply chain constraints and global competition for electricity infrastructure assets

The Australian power sector continues to be subject to ongoing supply chain issues for delivery of materials and equipment, as well as workforce and skills shortages.

In 2022, AEMO commissioned an update to its Transmission Cost Database to ensure that recent cost data can inform the 2024 ISP. Released in 2023, the update includes specialist cost estimation advice, which has been informed by recent transmission project tendering outcomes in the NEM.

After accounting for inflation, cost estimates provided in this report generally show up to approximately 30% increase in real costs compared to equivalent cost estimates prepared for the 2022 ISP. This increase is demonstrated in Figure 1, which compares cost estimates between the 2022 ISP and the 2024 ISP for projects with identical scopes.

Figure 1 Change in AEMO cost estimates for comparable projects between 2022 ISP and 2024 ISP

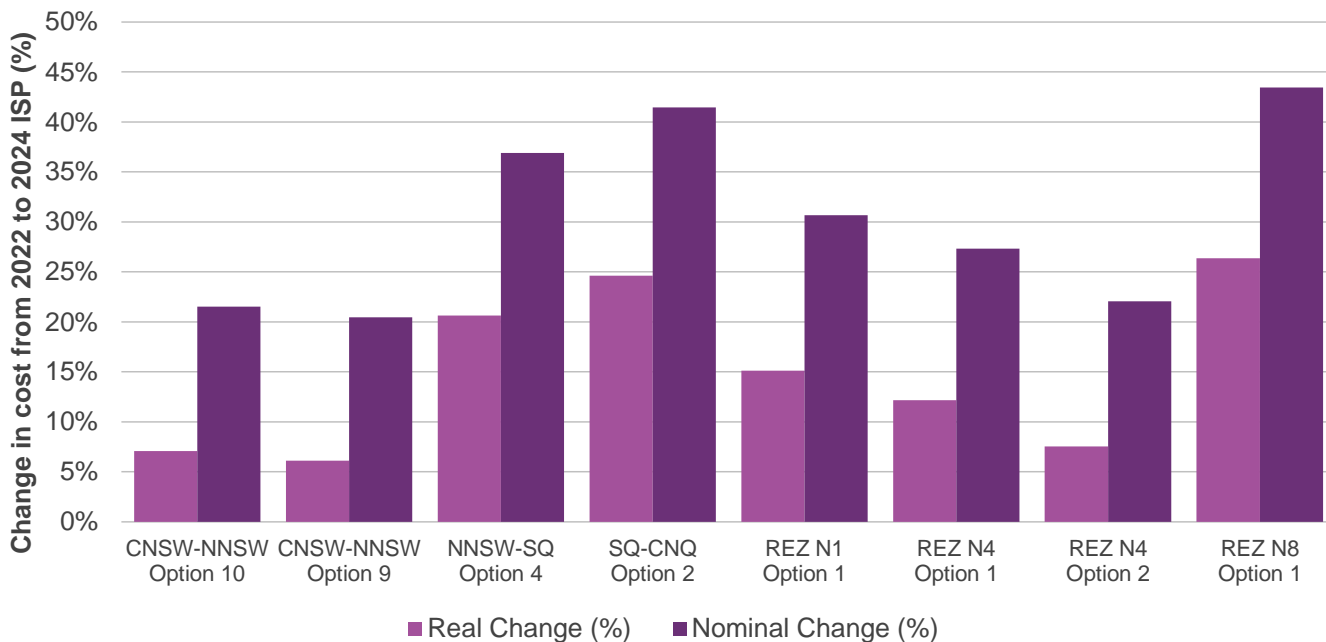

Transmission costs are expected to continue to increase

AEMO has prepared a new transmission cost forecasting approach for the 2024 ISP in response to unprecedented cost increases observed across the sector in recent years.

In previous ISPs, AEMO assumed that transmission network augmentation costs would increase in line with economy-wide inflation. Now, AEMO will apply additional escalation factors for individual cost components based on specialist advice and following stakeholder consultation. This incorporates forecasts such as commodity prices (oil, aluminium, copper and steel) and land cost.

AEMO expects that transmission project costs will continue to increase beyond the rate of inflation while the sector adapts to markets pressures driven by the global race to net zero. Figure 2 shows AEMO’s forecast of transmission costs over the ISP horizon, including an expectation that costs will level out at a new normal from:

- 2029-30 in the *Step Change* and *Green Energy Exports* scenarios.
- 2026-27 in the *Progressive Change* scenario.

AEMO will enhance its cost estimation approach for future ISPs as more evidence becomes available.

Figure 2 Transmission real cost trajectory for all planning scenarios

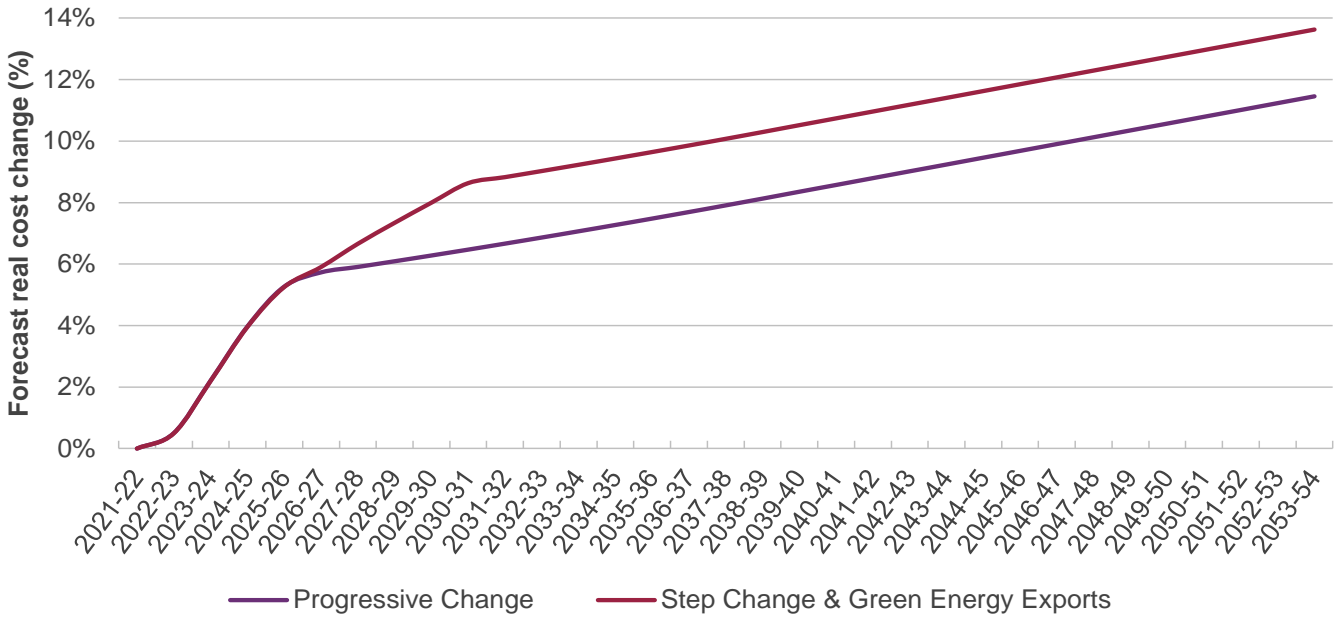

Leveraging industry expertise through stakeholder engagement

Stakeholder engagement on this report has included 20 public submissions, two confidential submissions, a submission provided verbally by consumer advocates, several stakeholder meetings, and attendance by more than 100 people at a webinar.

AEMO has published a consultation summary report outlining its responses to feedback received on the draft report¹, and thanks all stakeholders for their engagement. AEMO thanks TNSPs and jurisdictional bodies for the close joint planning work undertaken to prepare the report, including co-design of conceptual network options for the ISP. AEMO thanks the ISP Consumer Panel for their advice throughout the report’s development, and their recommendations for longer-term improvement.

AEMO looks forward to continuing to consult with industry, consumers and other stakeholders throughout the delivery of the 2024 ISP.

¹ At <https://aemo.com.au/consultations/current-and-closed-consultations/2023-transmission-expansion-options-report-consultation>.

Figure 3 Conceptual map of REZ expansion options and flow path augmentation options for 2023 Transmission Expansion Options Report

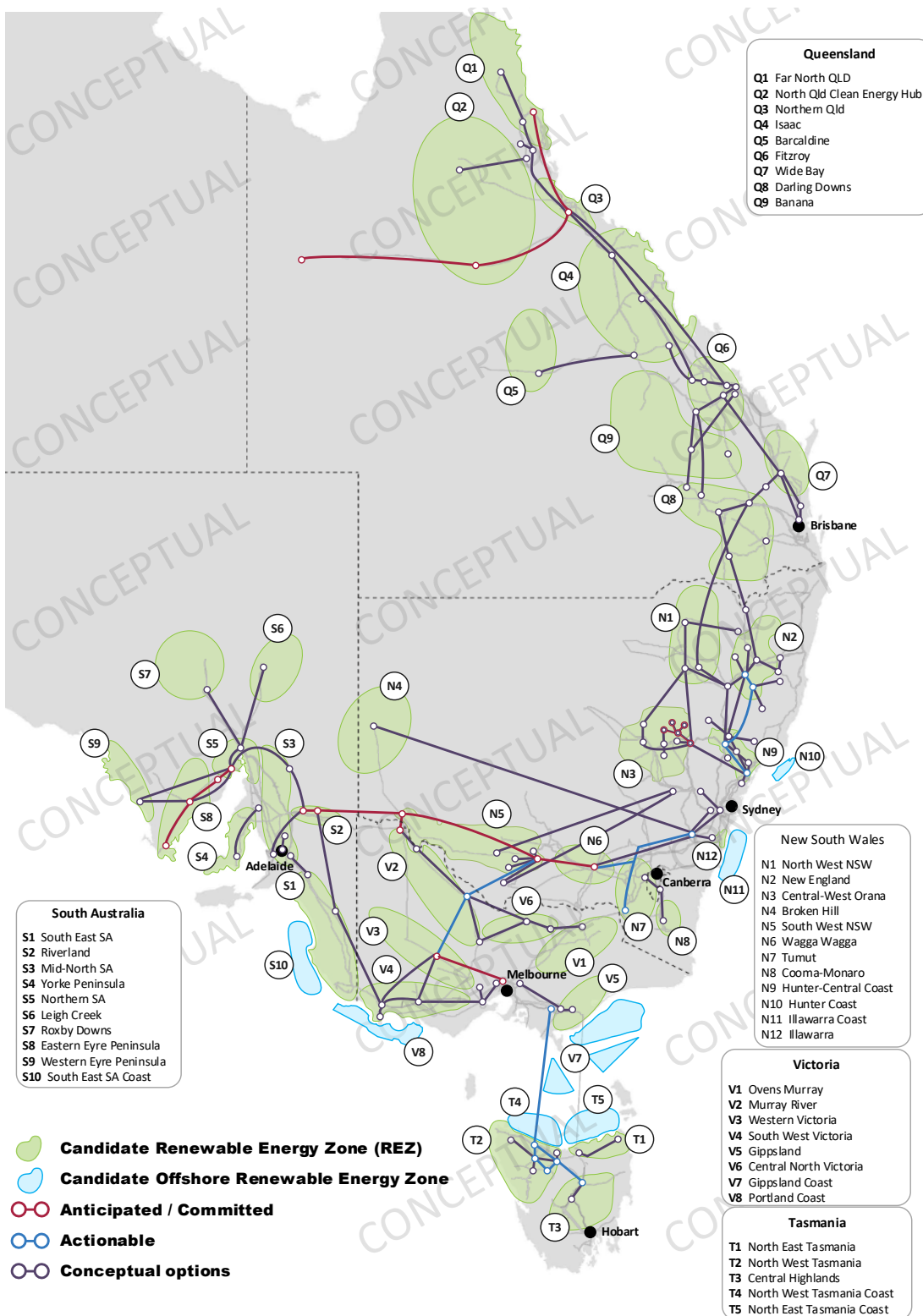

Contents

Executive summary	3
1 Introduction	10
1.1 Consultation process	10
1.2 Application of this report in the ISP	12
1.3 2024 ISP development process	17
2 Methodology	19
2.1 Cost estimation framework	19
2.2 Transmission Cost Database	23
2.3 Comparison of TNSP and AEMO cost estimates	28
2.4 Estimating operational expenditure	31
2.5 Landholder payment schemes	31
2.6 Economic, social and environmental costs and benefits	32
2.7 Market impacts on transmission costs	35
2.8 Projected changes in transmission infrastructure costs over time	35
2.9 Transmission project lead time	41
2.10 Social licence for transmission projects	42
3 Flow paths	44
3.1 Legend and explanation of tables	46
3.2 Central Queensland to North Queensland	48
3.3 Central Queensland to Gladstone Grid	50
3.4 Southern Queensland to Central Queensland	51
3.5 Northern New South Wales to Southern Queensland	53
3.6 Central New South Wales to Northern New South Wales	55
3.7 Central New South Wales to Sydney, Newcastle and Wollongong	57
3.8 Southern New South Wales to Central New South Wales	61
3.9 Victoria to Southern New South Wales	63
3.10 Tasmania to Victoria	65
3.11 Victoria to South East South Australia	67
3.12 South East South Australia to Central South Australia	69
4 Renewable Energy Zones	70
4.1 Legend and explanation of tables	72
4.2 New South Wales	74
4.3 Queensland	90
4.4 South Australia	107
4.5 Tasmania	120

4.6	Victoria	126
5	Generation connection costs	139
5.1	Generator connection costs	139
5.2	System strength costs	142
5.3	Offshore renewable energy zone design	142
A1.	Cost classification checklist	144

Tables

Table 1	Stakeholder engagement on the 2023 <i>Transmission Expansion Options Report</i>	11
Table 2	Related files and reports	12
Table 3	Committed and anticipated transmission projects for the 2024 ISP	14
Table 4	RIT-T projects in the 2024 ISP	15
Table 5	Future ISP projects with preparatory activities from the 2022 ISP	16
Table 6	Indicative ISP project development step	22
Table 7	Class 5 estimate sub-categories	26
Table 8	Comparison of TNSP and AEMO cost estimates	30
Table 9	Connection costs for solar and wind generation technologies	140
Table 10	Connection costs for other generation technologies (excluding batteries)	141
Table 11	Connection costs for batteries	141
Table 12	System strength services cost options	142

Figures

Figure 1	Change in AEMO cost estimates for comparable projects between 2022 ISP and 2024 ISP	4
Figure 2	Transmission real cost trajectory for all planning scenarios	5
Figure 3	Conceptual map of REZ expansion options and flow path augmentation options for 2023 <i>Transmission Expansion Options Report</i>	6
Figure 4	Consultation stages for the 2023 <i>Transmission Expansion Options Report</i>	12
Figure 5	AEMO's approach to incorporating transmission projects in the IASR and ISP	13
Figure 6	Navigating the ISP process	18
Figure 7	Design progress with project maturity – example showing how overhead line length assumption changes	20
Figure 8	Addition of unknown risk to determine a mid-point cost estimate for cost-benefit analysis	21

Figure 9	Cost estimate summary breakdown from Class 5b to Class 1	25
Figure 10	Indicative unit cost multiplier from HVAC overhead lines to HVAC underground cables	34
Figure 11	Forecast cumulative cost changes for transmission projects: plant, materials, and easement and property costs, in real terms	38
Figure 12	Forecast cumulative cost changes for transmission project cost components: construction, services and secondary (electrical) systems, in real terms	38
Figure 13	Application of transmission cost forecasting methodology to a sample project, in real terms	39
Figure 14	Forecast average cost changes (real \$2023) for flow path, REZ and generator connection projects, <i>Step Change</i> and <i>Green Energy Export</i> scenarios, 2021-22 to 2053-54	39
Figure 15	Forecast average cost changes (real \$2023) for flow path, REZ and generator connection projects, <i>Progressive Change</i> scenario, 2021-22 to 2053-54	40
Figure 16	Indicative trends for the transmission forecasting approaches for the ISP (real \$2023)	40
Figure 17	Conceptual map of flow path options for 2023 <i>Transmission Expansion Options Report</i>	45
Figure 18	Candidate REZs and REZ augmentation options for 2023 <i>Transmission Expansion Options Report</i>	71
Figure 19	Connection cost representation	139
Figure 20	Offshore renewable energy zone design and connection to existing network	143

1 Introduction

AEMO's *Integrated System Plan* (ISP) is a whole-of-system plan that provides a comprehensive roadmap for the efficient development of the National Electricity Market (NEM) over at least 20 years. The ISP supports Australia's complex and rapid energy transformation towards net zero emissions, enabling low-cost firming renewable energy and essential transmission to provide consumers in the NEM with reliable, secure and affordable power.

Leveraging expertise from across the industry is pivotal to the development of a robust plan that supports the long-term interests of energy consumers. AEMO is committed to taking a consultative approach to developing the 2024 ISP. The conceptual design, lead time, lead time and cost estimates for transmission expansion options are vital inputs to the process that determines whether transmission projects should proceed².

This 2023 *Transmission Expansion Options Report* forms part of the 2023 *Inputs, Assumptions and Scenarios Report* (IASR). It describes the engagement of independent experts and provision of industry and stakeholder advice, culminating in a report summarising the conceptual design, lead time, location and cost estimates for candidate transmission projects for the 2024 ISP.

Section 1 outlines the context for this report:

- Consultation process (Section 1.1).
- Application of this report in the ISP (Section 1.2).
- 2024 ISP development process (Section 1.3).

1.1 Consultation process

AEMO is publishing this report on the transmission augmentation options under consideration for the 2024 ISP, including conceptual design, lead time, location and cost estimates.

This report is published as a supporting publication for the 2023 IASR and in accordance with the Australian Energy Regulator's (AER's) Forecasting Best Practice Guidelines³.

Consultation stages for the Transmission Expansion Options Report

Table 1 notes the summary of engagement dates for the inputs to the 2024 Draft ISP.

AEMO will host a 90-minute webinar on Thursday 10 August 2023, from 2.00 pm to 3.30 pm (AEST). AEMO will present the key transmission expansion and cost outcomes in this report, and allow time for questions. Interested stakeholders can sign up to attend the webinar here⁴.

² AEMO is currently consulting on proposed amendments to the ISP Methodology, seeking any stakeholder submissions by 1 May 2023. Information about the consultation is available at <https://aemo.com.au/consultations/current-and-closed-consultations/consultation-on-updates-to-the-isp-methodology>. AEMO intends to respond to stakeholder feedback and finalise amendments to the ISP Methodology by 30 June 2023.

³ At <https://www.aer.gov.au/system/files/AER%20-%20Forecasting%20best%20practice%20guidelines%20-%202025%20August%202020.pdf>.

⁴ At <https://events.teams.microsoft.com/event/10427dfd-51e4-46a2-b9b5-c5cdf010d3e7@320c999e-3876-4ad0-b401-d241068e9e60>.

Table 1 Stakeholder engagement on the 2023 Transmission Expansion Options Report

Activity	Date
Draft IASR published	16 December 2022
Draft ISP methodology published	31 March 2023
Draft <i>Transmission Expansion Options Report</i> published	2 May 2023
Draft <i>Transmission Expansion Options Report</i> webinar	18 May 2023
ISP Methodology published	30 June 2023
<i>Transmission Expansion Options Report</i> published Final IASR published	28 July 2023
Final <i>Transmission Expansion Options Report</i> webinar	10 August 2023
Draft ISP published	15 December 2023

Stakeholder submissions in response to the Draft 2023 *Transmission Expansion Options Report*

In response to its draft report, AEMO received 20 public written submissions, two confidential submissions, and a submission provided verbally by consumer advocates. AEMO also held a public webinar attended by more than 100 people, and held two information and verbal submission sessions for consumer advocates.

AEMO met with several stakeholders to discuss their submissions. Minutes from these discussions can be viewed on the consultation page⁵.

AEMO has published all written submissions (except for confidential submissions), as well as a standalone consultation summary report⁶.

The Draft 2023 *Transmission Expansion Options Report* documented conceptual designs, lead times, location and cost estimates. The report included the latest information available at that time, and noted what information was still outstanding. This final 2023 *Transmission Expansion Options Report* now provides the updated information.

Supplementary materials

Table 2 outlines related files and reports that have been used to determine transmission costs in the 2023 *Transmission Expansion Options Report*. Stakeholders are invited to refer to these documents for further background and context.

⁵ At <https://aemo.com.au/consultations/current-and-closed-consultations/2023-transmission-expansion-options-report-consultation>.

⁶ At <https://aemo.com.au/consultations/current-and-closed-consultations/2023-transmission-expansion-options-report-consultation>.

Table 2 Related files and reports

Document	Description	Location
Transmission Cost Database Update Final Report	Describes the update made to the AEMO Transmission Cost Database in 2023 by independent consultant Mott MacDonald.	https://aemo.com.au/consultations/current-and-closed-consultations/2023-transmission-expansion-options-report-consultation
Transmission Cost Database version 2.0	Database of cost estimate inputs and cost estimating tool used for estimating future ISP transmission expansion options and, in some cases, where cost estimates are not available from a project proponent. Version 2.0 includes a 2023 update to the database.	Available by request. Please complete the form on AEMO’s web page to receive the updated Transmission Cost Database: https://aemo.com.au/consultations/current-and-closed-consultations/2023-transmission-expansion-options-report-consultation
Draft transmission cost estimate calculations	A compressed ZIP file containing AEMO Transmission Cost Database output files for each project option in the 2023 <i>Transmission Expansion Options Report</i> that has been estimated using the Transmission Cost Database. In cases where a project cost estimate is based on confidential materials provided by the project proponent based on tendering information or similar, the cost estimates may not be included for download. These records show the makeup of AEMO’s transmission cost estimates – including building blocks, adjustments, risk and indirect costs.	https://aemo.com.au/consultations/current-and-closed-consultations/2023-transmission-expansion-options-report-consultation

Figure 4 Consultation stages for the 2023 Transmission Expansion Options Report

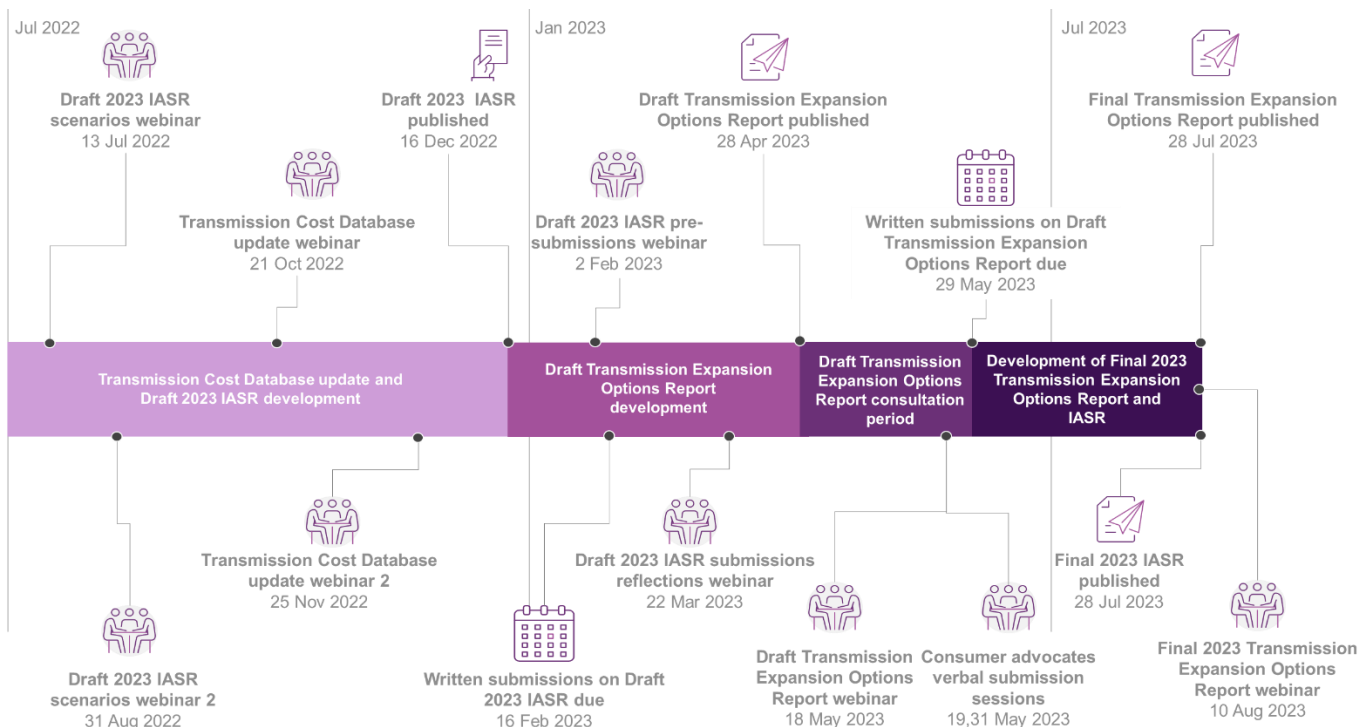

1.2 Application of this report in the ISP

Transmission network augmentation options – particularly their conceptual design, lead time, location and cost estimates – are key inputs to development of the ISP. A combination of these options will be used in the selection of the optimal development path (ODP). The ODP identifies new transmission projects that are actionable now as

well as in the future, and also includes new generation and storage to efficiently deliver firmed renewable energy to consumers through the NEM⁷.

AEMO seeks to co-design conceptual network options for the ISP with transmission network service providers (TNSPs) and NEM jurisdictional bodies. AEMO, TNSPs and jurisdictions have collaborated to undertake the extensive joint planning necessary to prepare this draft report. These bodies include Powerlink, Transgrid, EnergyCo, AEMO in its capacity as the Victoria Transmission Planner, VicGrid, ElectraNet, MarinusLink, TasNetworks, and other relevant jurisdictional bodies. In some cases, the 2023 *Transmission Expansion Options Report* incorporates advice from project proponents for committed and anticipated transmission projects, as well as draft preparatory activities reports requested for the 2024 ISP.

The 2024 ISP will use transmission project options from the final 2023 *Transmission Expansion Options Report*, which will form part of the 2023 IASR. The final 2023 IASR has also been published on the AEMO website⁸. Where updated cost estimate information is provided to AEMO by TNSPs for future ISP projects with preparatory activities, and for projects undergoing the Regulatory Investment Test for Transmission (RIT-T) process, AEMO has completed cross-checks of this information⁹ using the latest Transmission Cost Database.

Figure 5 shows AEMO’s approach to incorporating transmission project cost estimates in the ISP for different project categories. The following sections provide further information about the projects that fall within each category.

Figure 5 AEMO’s approach to incorporating transmission projects in the IASR and ISP

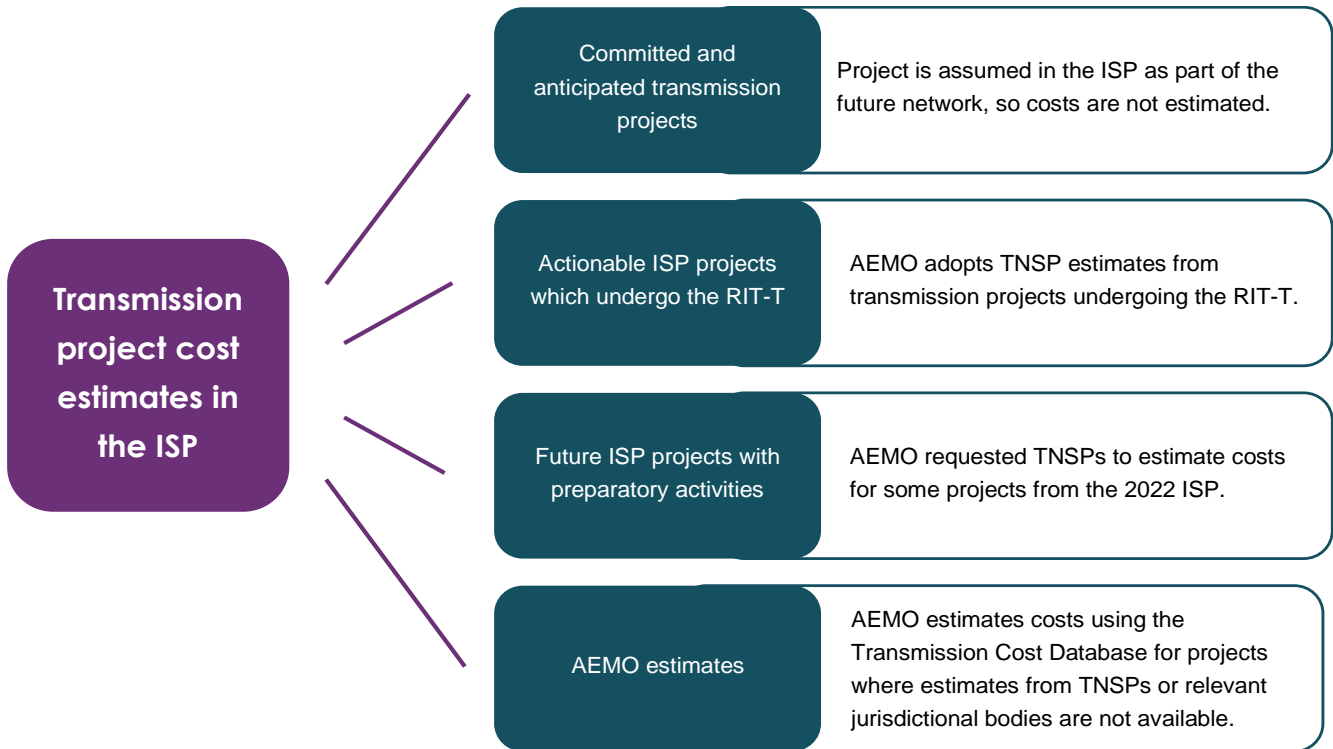

⁷ For further information about the ISP modelling approach and the selection of the ODP please see the ISP Methodology. The current version of the methodology is at: <https://aemo.com.au/energy-systems/major-publications/integrated-system-plan-isp/2024-integrated-system-plan-isp/isp-methodology>. AEMO has consulted on updates to the methodology, for application in the 2024 ISP. Information on this consultation can be found at: <https://aemo.com.au/consultations/current-and-closed-consultations/consultation-on-updates-to-the-isp-methodology>.

⁸ At <https://aemo.com.au/consultations/current-and-closed-consultations/2023-inputs-assumptions-and-scenarios-consultation>.

⁹ Section 2.3 provides information about the transmission project cost estimate cross-checking process.

Committed and anticipated transmission projects

Transmission projects being developed and delivered by TNSPs or relevant NEM jurisdictional bodies may be categorised as committed or anticipated:

- Committed transmission augmentation projects meet five criteria relating to planning consents, construction commencement, land acquisition, contracts for supply and construction of equipment, and necessary financing arrangements.
- Anticipated projects are in the process of meeting at least three of the criteria.

Details about the criteria for committed and anticipated project status are provided in AEMO's Transmission Augmentation Information publication¹⁰, and are consistent where relevant with five criteria defined for committed projects in the AER's Cost Benefit Analysis Guidelines¹¹ and RIT-T¹² instruments.

AEMO includes all committed and anticipated projects in all future states of the world for the purposes of forecasting and planning publications, in accordance with the AER's Cost Benefit Analysis Guidelines. Because these projects are assumed to proceed, the projects' costs are not re-evaluated for the purposes of the ISP.

Table 3 lists transmission projects that are currently classified as committed or anticipated. AEMO may use updated information in the ISP, for example as included in the latest Transmission Augmentation Information publication. For AEMO's review of TNSP cost estimates using the Transmission Cost Database, see Section 2.3.

Table 3 Committed and anticipated transmission projects for the 2024 ISP

Project	Status	Responsible TNSP(s) or jurisdictional bodies	More information
Central-West Orana REZ Transmission Link	Anticipated	EnergyCo	https://www.energyco.nsw.gov.au/cwo .
Eyre Peninsula Link	Committed	ElectraNet	https://www.electranet.com.au/projects/eyre-peninsula-link/
VNI Minor (also named VNI East Upgrade)	Committed	AEMO (Victorian Planning), Transgrid	https://aemo.com.au/initiatives/major-programs/vni-west https://www.transgrid.com.au/projects-innovation/victoria-to-nsw-interconnector
QNI (Queensland - New South Wales Interconnector) Minor	Committed	Transgrid	https://www.transgrid.com.au/projects-innovation/queensland-nsw-interconnector https://www.powerlink.com.au/expanding-nsw-qld-transmission-transfer-capacity
Northern QREZ	Committed	Powerlink	https://www.powerlink.com.au/queensland-renewable-energy-zones
Project EnergyConnect - Stage 1	Committed	ElectraNet, Transgrid	https://www.electranet.com.au/projects/project-energyconnect/ https://www.transgrid.com.au/projects-innovation/energyconnect
Project EnergyConnect - Stage 2	Committed	ElectraNet, Transgrid	https://www.electranet.com.au/projects/project-energyconnect/ https://www.electranet.com.au/projects/project-energyconnect/

¹⁰ At <https://aemo.com.au/energy-systems/electricity/national-electricity-market-nem/nem-forecasting-and-planning/forecasting-and-planning-data/transmission-augmentation-information>.

¹¹ At <https://www.aer.gov.au/system/files/AER%20-%20Cost%20benefit%20analysis%20guidelines%20-%202025%20August%202020.pdf>.

¹² AER. Regulatory investment test for transmission. August 2020. At <https://www.aer.gov.au/system/files/AER%20-%20Regulatory%20investment%20test%20for%20transmission%20-%202025%20August%202020.pdf>.

Project	Status	Responsible TNSP(s) or jurisdictional bodies	More information
Murray River REZ and Western Victoria REZ minor augmentations	Committed	AEMO (Victorian Planning)	Pg. 67, 2022 <i>Victorian Annual Planning Report</i> , at https://aemo.com.au/energy-systems/electricity/national-electricity-market-nem/nem-forecasting-and-planning/victorian-planning/victorian-annual-planning-report
Victoria Central North REZ minor augmentations	Committed	AEMO (Victorian Planning)	Pg. 68, 2022 <i>Victorian Annual Planning Report</i>
Mortlake Turn-In	Committed	AEMO (Victorian Planning)	Pg. 68, 2022 <i>Victorian Annual Planning Report</i>
Waratah Super Battery Network Augmentations and SIPS Control	Committed	EnergyCo	https://www.energyco.nsw.gov.au/projects/waratah-super-battery
Ararat synchronous condenser	Committed	AEMO (Victorian Planning)	Pg. 69, 2022 <i>Victorian Annual Planning Report</i>
Western Renewables Link	Anticipated	AEMO (Victorian Planning)	https://www.westernrenewableslink.com.au/
CopperString 2032	Anticipated	Powerlink	https://statements.qld.gov.au/statements/97314

Note. Some smaller committed and anticipated transmission augmentation projects have not been included here, but may be found in AEMO's Transmission Augmentation Information page or the websites of the relevant TNSPs or jurisdictional bodies. For ISP power system analysis purposes, the most up-to-date model of the network is used, including relevant small and large projects.

Actionable ISP projects which undergo the RIT-T

Actionable ISP projects undergo the RIT-T. The proponent TNSP proceeds through a staged consultation process to prepare and select options to meet the project need. Further review processes – such as the ISP feedback loop and a Contingent Project Application to the AER – are also undertaken before a TNSP is enabled to recover revenue for the project.

For the ISP modelling process, AEMO requests updated cost estimates and augmentation information from TNSPs for projects currently being assessed under the RIT-T, as the projects progress. Because these projects remain highly uncertain, they are modelled as augmentation options in the ISP (that is, they are not assumed to proceed). AEMO considers that TNSPs are best placed to estimate the cost of these projects. To ensure consistency across regions, AEMO reserves the right to add offsets to prices advised by TNSPs to ensure uncertainty and risks are applied consistently across investment options.

Table 4 lists the RIT-T projects that will be included in the 2024 ISP. AEMO may also use updated information in the ISP, for example as included in the latest Transmission Augmentation Information publication.

Table 4 RIT-T projects in the 2024 ISP

Project	Responsible TNSP(s)	Section in this report
HumeLink	Transgrid	Section 3.8
VNI West	Transgrid and AEMO (Victorian Planning)	Section 3.9
Marinus Link	TasNetworks, Marinus Link	Section 3.10

Future ISP projects with preparatory activities

Preparatory activities are intended to improve the conceptual design, lead time, location and cost estimates for transmission projects. The ISP may require preparatory activities for some future ISP projects. Future ISP projects are projects which address an identified need, form part of the ODP, and may be actionable ISP projects in the future.

Table 5 lists the future ISP projects for which AEMO has required preparatory activities, including cost estimates, from TNSPs. At the time of publication of this report, AEMO has received draft confidential preparatory activities for these future ISP projects. Final preparatory activities reports are due to AEMO by the end of June 2023.

Table 5 Future ISP projects with preparatory activities from the 2022 ISP

Project	2022 ISP timing	Preparatory activities required by	Responsible TNSP(s)	Section(s) in this report
South East SA REZ expansion (Stage 1)	2025-26 to 2045-49	30 June 2023	ElectraNet	Section 4.4.1
Darling Downs REZ Expansion (Stage 1)	2025-26 to 2047-48	30 June 2023	Powerlink	Section 4.3.8
Mid-North SA REZ Expansion	≥ 2028-29	30 June 2023	ElectraNet	Section 4.4.3
QNI Connect (500 kV option)	2029-30 to 2036-37	30 June 2023	Powerlink and Transgrid	Section 3.5
QNI Connect (330 kV option – NSW scope)	2029-30 to 2036-37	30 June 2023	Transgrid	Section 3.5
South West Victoria REZ Expansion	≥ 2033-34	30 June 2023	AEMO (Victorian Planning)	Section 4.6.4

AEMO estimates

There are many transmission projects assessed in the ISP where TNSPs and jurisdictional bodies have not developed augmentation options and cost estimates. For these projects, AEMO determines and consults on conceptual augmentation options and cost estimates, including through extensive joint planning with the relevant TNSP.

AEMO uses the latest version of the AEMO Transmission Cost Database¹³ to cost the transmission expansion project options for which cost estimates have not been developed by TNSPs or jurisdictional bodies. Section 2.2.3 provides further information about the update to the AEMO Transmission Cost Database undertaken in preparation for the 2024 ISP.

This report outlines options for transmission augmentation projects. Section 2 lays out the methodology for key conceptual design, project lead time, location and costing matters.

The augmentation options are then provided, split into:

- **Flow paths** – the portion of the transmission network used to transport significant amounts of electricity across the backbone of the interconnected network to load centres – see Section 3.
- **REZs** – the network required to connect renewable generation in areas where cluster of large-scale renewable energy can be developed using economies of scale – see Section 4.
- **Generation connection** – generator connection cost matters, including system strength costs, treatment of offshore resource connections, and connection costs for onshore generators – see Section 5.

¹³ Version 2.0 of the AEMO Transmission Cost Database, released April 2023, is accessible at <https://aemo.com.au/energy-systems/major-publications/integrated-system-plan-isp/2024-integrated-system-plan-isp/current-inputs-assumptions-and-scenarios>. Register to receive it at <https://forms.office.com/r/YbmiGc24TP>.

1.3 2024 ISP development process

Figure 6 shows the ISP process as a whole and current progress on all elements for the 2024 ISP¹⁴. In addition to the 2023 *Transmission Expansion Options Report* consultation process, two other consultations that will inform the 2024 ISP have been completed:

- **The update to the ISP Methodology**¹⁵ considered eight proposed updates to the methodology which sets out how modelling is applied in the ISP and how cost benefit analysis is used in the ISP. The update included stakeholder submissions received by 1 May 2023, publication of the final update to the ISP Methodology on 30 June 2023, and a webinar on 13 July 2023 to summarise key changes.
- **The 2023 IASR** catalogues the range of inputs, assumptions and scenarios for the 2024 ISP. AEMO received 69 submissions on the Draft 2023 IASR, hosted a webinar, and has finalised responses to feedback in order to publish the final 2023 IASR in parallel with the publication of this report¹⁶.

¹⁴ The 2024 ISP Timetable provides more information on the key milestones of the 2024 ISP development process, at <https://aemo.com.au/-/media/files/major-publications/isp/2022/2024-isp-timetable.pdf?la=en>.

¹⁵ AEMO. Consultation on updates to the ISP Methodology. At <https://aemo.com.au/consultations/current-and-closed-consultations/consultation-on-updates-to-the-isp-methodology>.

¹⁶ AEMO. 2023 Inputs Assumptions and Scenarios Consultation. At <https://aemo.com.au/consultations/current-and-closed-consultations/2023-inputs-assumptions-and-scenarios-consultation>.

Figure 6 Navigating the ISP process

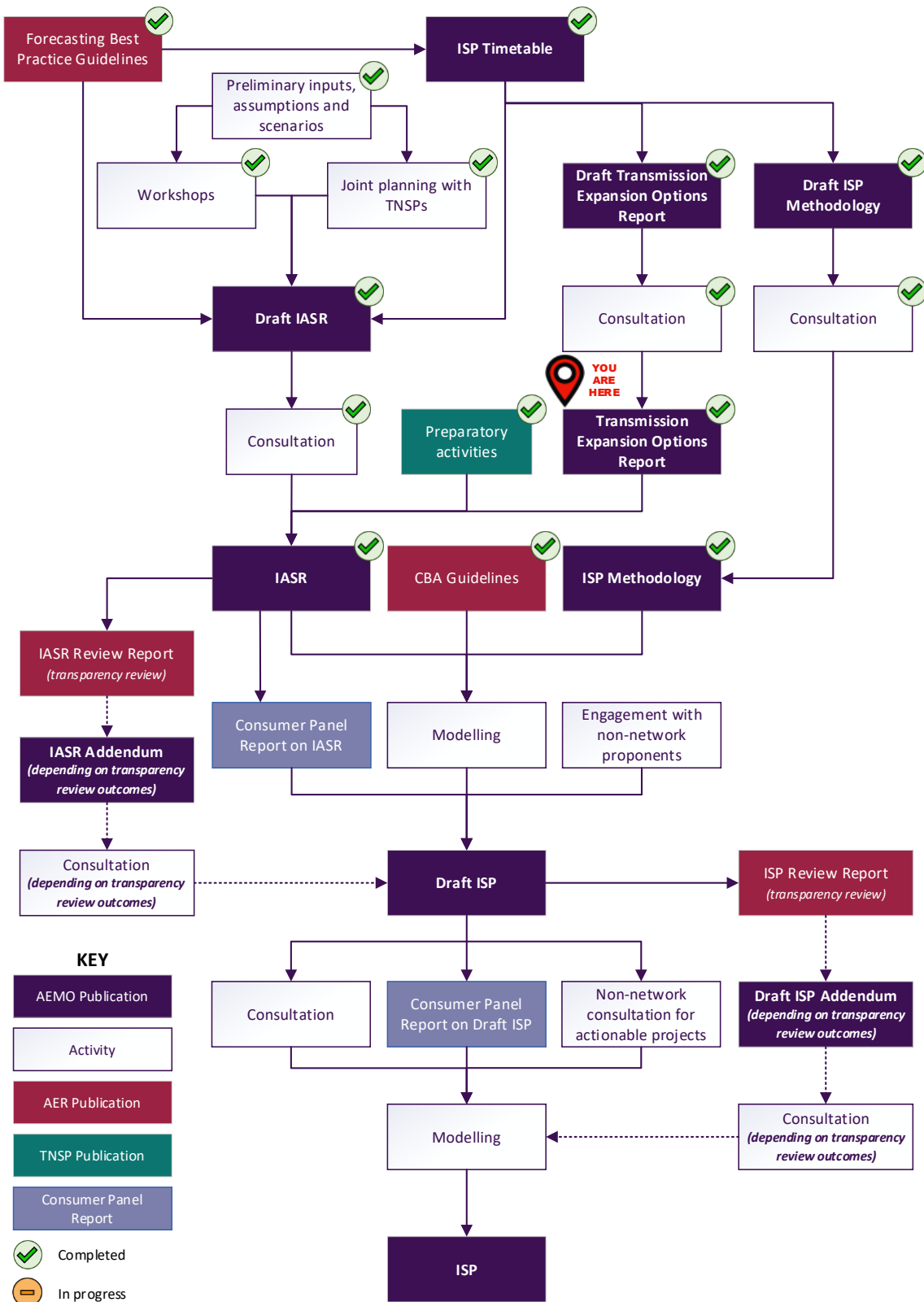

Note: The diagram above has been amended from the version published in the 2024 ISP timetable by adding a box containing "Draft Transmission Expansion Options Report" and "Transmission Expansion Options Report" with an additional "Consultation" box. The IASR will consider transmission development options and non-network alternatives.

2 Methodology

AEMO assesses conceptual design, project lead time, location, and cost estimates for transmission augmentation options that will be considered in the ISP. AEMO seeks to collaborate with TNSPs and jurisdictional bodies to co-design network options for the ISP. AEMO, TNSPs and jurisdictional bodies have undertaken extensive joint planning to inform the preparation of this report. This section outlines the methodology for assessing these options.

In response to feedback from stakeholders, AEMO initiated a work program after the 2022 ISP to continue to improve the transparency and robustness of the transmission cost estimation process used in the ISP. This included a new Transmission Cost Database which is used to estimate the cost of transmission projects. The process used to estimate transmission project costs is outlined in the following sections, along with a process to ensure consistency with TNSP project estimates.

Section 2 outlines the methodology for assessing transmission augmentation project options:

- Cost estimation framework (Section 2.1).
- AEMO Transmission Cost Database (Section 2.2).
- Review of TNSP cost estimates (Section 2.3).
- Estimating operational expenditure (Section 2.4).
- Landholder payment schemes (Section 2.5).
- Economic, social and environmental costs and benefits (Section 2.6).
- Market impacts on transmission costs (Section 2.7).
- Projected changes in infrastructure costs over time (Section 2.8).
- Transmission project lead time (Section 2.9).
- Social licence for transmission projects (Section 2.10).

2.1 Cost estimation framework

This section outlines the treatment of cost estimate classifications and their application for the ISP, including the approach for incorporating risk.

2.1.1 Treatment of cost estimate classifications for the ISP

This section provides a high-level description of the complex process that is used to develop transmission projects, and relevant generic background on the nature of cost estimation. The content represents AEMO's understanding of the typical stages of project development and estimation used by Australian TNSPs, noting that this may vary for individual TNSPs. The content is not prescriptive, and stakeholders are referred to the AER Cost Benefit Analysis Guidelines¹⁷ and RIT-T Application Guidelines¹⁸ for more information.

¹⁷ At <https://www.aer.gov.au/system/files/AER%20-%20Cost%20benefit%20analysis%20guidelines%20-%202025%20August%202020.pdf>.

¹⁸ At <https://www.aer.gov.au/system/files/AER%20-%20Regulatory%20investment%20test%20for%20transmission%20application%20guidelines%20-%202025%20August%202020.pdf>.

Cost estimates progress from a very early stage with little design or information known (least accurate) to a fully costed and engineered estimate (most accurate).

In the early stages, allowances are used to account for the fact that the work scope is not well defined, project approvals have not yet been obtained, and component costs may not be market-tested. Because these allowances are uncertain, the accuracy of early estimates is low. As projects mature and the scope of works is further defined, more of the cost is assigned to the base estimate, reducing the size of allowances for risks and uncertainties, and improving the accuracy.

The Association for Advancement of Cost Engineering (AACE) International classification system is commonly used in many industries for defining the level of accuracy of a cost estimate, based on the amount of design work that has been done. This system defines a series of ‘classes’ of estimates, ranging from Class 5 (least accurate) to Class 1 (most accurate). AEMO has followed the framework of the AACE International guideline for its cost estimate methodology to classify cost estimates, and defined sub-categories to reflect the range of estimates and accuracies that are available within the Australian regulated electricity sector. These are defined as follows:

- Class 5b – concept level scoping with no site-specific review or TNSP input.
- Class 5a – screening level scoping including high level site-specific review and TNSP input.

Further detail on the associated accuracies of these classes is provided in Section 2.2.2.

Figure 7 illustrates how the definition of a single parameter within an estimate (using the example of transmission overhead line length) is progressed as a project matures from a Class 5b to Class 2 or 1 within the framework. Studies in the early stages (Class 5b/5a/4/3) are usually confined to desktop analysis, with field work only introduced from Class 3 or later in the project development.

It is important to note that this process does not rely on a linear maturation of the scope of works; rather, Class 5b (the earliest stage) relies on significantly fewer inputs than what would be required for Class 4 or Class 3. It must also be noted that accuracy bands are ascribed on the basis of the whole project, not as individual elements.

Figure 7 Design progress with project maturity – example showing how overhead line length assumption changes

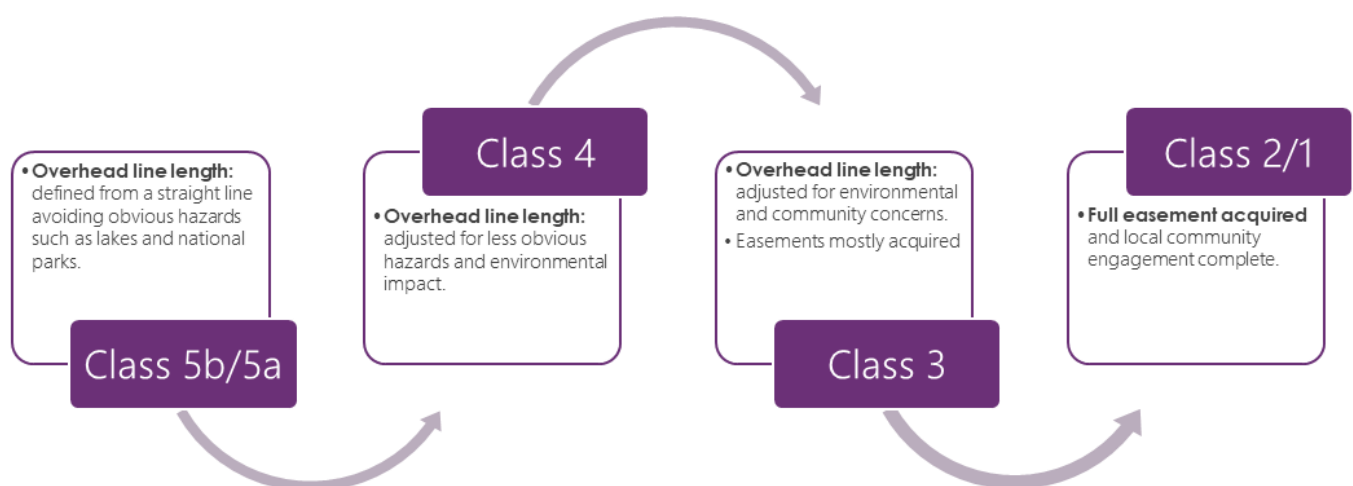



Deviation from the AACE cost estimation framework

AEMO acknowledges that its approach to applying cost estimation in the ISP may be considered to deviate from the AACE framework in two superficial ways:

- Splitting class 5 into two categories** – the AACE framework for power transmission line infrastructure sets out a range of accuracy bands for all estimate classes. Because the ISP includes a wide range of Class 5 estimates, AEMO has decided to categorise estimates as “Class 5a” or “Class 5b” as a succinct way to reflect whether the estimate is at the upper bound or lower bound of the accuracy range.
- Presentation of symmetric accuracy bands** – the AACE framework reflects that cost estimates typically have an asymmetrical risk profile (for example, a project might have a -50% to +100% accuracy range). While AEMO agrees that cost estimates have an asymmetric risk profile, the AACE framework presents an approach for estimating costs but does not specify how the uncertainty range should be applied in a cost-benefit analysis.

In the ISP, AEMO uses the AACE framework to determine a point cost estimate with an asymmetrical uncertainty range for a cost estimate, but then applies an unknown risk factor to uplift the point cost estimate while leaving the lower and upper ends of the accuracy range constant. The result of this increase from a point cost to a mid-point cost is that the resulting uncertainty range is symmetric. Adding this ‘contingency’ to the point estimate does not affect estimate accuracy; this is shown in Figure 8 below. This approach closely aligns with an example in AACE documentation, although no guidance is provided on how accuracy bands should be articulated following the addition of a contingency allowance.

Figure 8 Addition of unknown risk to determine a mid-point cost estimate for cost-benefit analysis

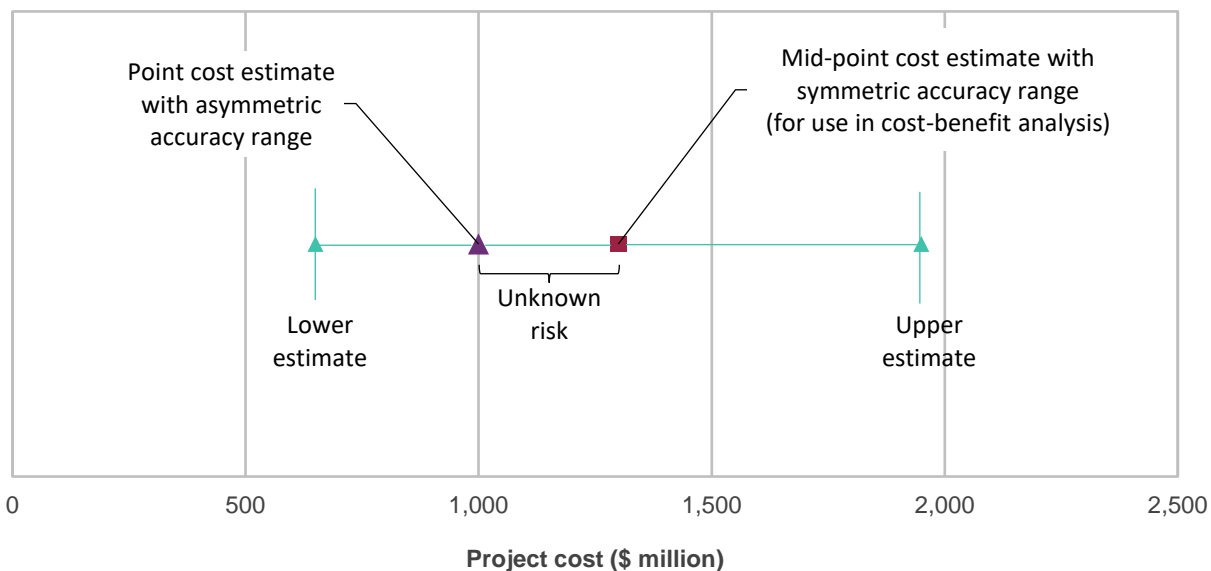

2.1.2 Application to the ISP

The development of the Transmission Cost Database has helped refine AEMO’s approach to cost estimation, and informed the definition of the work needed across each step of development.

Table 6 shows the current steps for ISP projects and outlines the planning and development works that typically take place at each step. The indicative class levels shown here reflect AEMO’s current understanding of levels typically used at each step, which may vary across the TNSPs and across projects. The AER Cost Benefit

Analysis Guidelines¹⁹ and RIT-T Application Guidelines²⁰ outline the expectations for each stage of the RIT-T, however they do not stipulate a specific class level for cost estimates, as estimate accuracy achieved at each step will depend on the nature of the project.

Table 6 Indicative ISP project development step

Step	Future ISP projects identification (by AEMO)	Preparatory activities for future projects	Project Assessment Draft Report (PADR)	Project Assessment Conclusions Report (PACR)	Contingent Project Application (CPA) ^A
Description	<ul style="list-style-type: none"> • Identification of future projects to include in the ISP • High-level assessment of potential costs/benefits to determine whether project has net benefits 	<ul style="list-style-type: none"> • More detailed analysis of project options to determine provisional preferred option, and refine time, cost and technical scopes 	<ul style="list-style-type: none"> • Comparison of credible options to identify a draft preferred option 	<ul style="list-style-type: none"> • Final report on the comparison of credible options to determine the preferred option, taking into account submissions received on PADR 	<ul style="list-style-type: none"> • Final application to AER for revenue adjustment to reflect costs of the project
Cost estimates informed by	<ul style="list-style-type: none"> • High-level technical specifications developed (e.g. voltage/ capacity and conceptual single line diagrams) • Class 5b: Network path identified at concept level with no site-specific review or TNSP input • Class 5a: Network path identified at screening level with some site-specific review and TNSP input 	<ul style="list-style-type: none"> • Technical specifications refined, relevant network studies underway • For significant projects a non-committal budget (guide) estimate from appropriate contractors/suppliers may be sought • Desktop geotechnical/ecology/heritage/planning study undertaken, and some fieldwork may be undertaken in identified high risk areas • Stakeholder engagement plan developed • Credible alignment path identified, avoiding significant known risks and environmental sensitivities • Biodiversity offset liability estimated based on ecology reports available • Corporate cost budget estimated at a high level 	<ul style="list-style-type: none"> • Technical specifications refined, relevant network studies substantially complete • Concept tower and substation design further refined • For significant projects a non-committal budget (guide) estimate from appropriate contractors/suppliers may be sought • Desktop geotechnical/ecology/heritage/planning study undertaken, and some fieldwork may be undertaken in identified high risk areas • Credible network option identified based on geotechnical/ecology/heritage and tenure desktop planning and network studies • Biodiversity offset liability estimated based on ecology reports available • Corporate cost budget estimated at a high level 	<ul style="list-style-type: none"> • Technical specifications completed • For significant projects a non-committal budget (guide) estimate from appropriate contractors/suppliers may be sought • Desktop geotechnical/ecology/heritage/planning study undertaken, and some fieldwork may be undertaken in identified high risk areas • Major landowners identified • Credible network option further refined • Biodiversity offset liability estimated based on ecology reports available • Corporate cost budget estimated at a high level 	<ul style="list-style-type: none"> • Detailed technical specifications completed for market costing • Market engagement complete, procurement substantially progressed • Detailed geotechnical investigations substantially progressed • Procurement of options over easement commenced, initial consultation with landowners substantially complete • Alignment progressing to finalisation apart from micro-siting issues • Biodiversity offset liability determined and strategy finalised • Ecology/heritage studies substantially progressed • Planning approval commenced • Corporate cost budget finalised

¹⁹ At <https://www.aer.gov.au/system/files/AER%20-%20Cost%20benefit%20analysis%20guidelines%20-%202025%20August%202020.pdf>.

²⁰ At <https://www.aer.gov.au/system/files/AER%20-%20Regulatory%20investment%20test%20for%20transmission%20application%20guidelines%20-%202025%20August%202020.pdf>.

Step	Future ISP projects identification (by AEMO)	Preparatory activities for future projects	Project Assessment Draft Report (PADR)	Project Assessment Conclusions Report (PACR)	Contingent Project Application (CPA) ^A
Approximate class	Class 5	Class 4 to 5	Class 4 to 5	Class 3 to 5	Class 2 to 4 ^B
Cost source for ISP modelling	Transmission Cost Database	Primary cost estimate from TNSPs, cross check with Transmission Cost Database	Primary cost estimate from TNSPs, cross check with Transmission Cost Database	Primary cost estimate from TNSPs, cross check with Transmission Cost Database	Not required for committed projects

- A. Regulations differ in Victoria, where there is no CPA stage following the RIT-T.
- B. Unknown risk allowances are intended to be used in the Transmission Cost Database for projects at RIT-T or earlier stages. The AER's guidance note on the regulation of actionable ISP projects expects that unknown risks should not be included at the CPA stage, and that TNSPs should undertake activities to identify all risks prior to submission of the CPA.

AEMO produces cost estimates for future ISP projects using the Transmission Cost Database, which was initially designed to produce Class 5a estimates from screening level scope definition. The Transmission Cost Database has been updated to produce both Class 5a and Class 5b estimates. Class 5b applies unknown risk factors that are twice that of the Class 5a unknown risk factors. This update was driven by confidential project cost data which provided evidence to support this approach. This replaces the previous approach which was to apply a factor to the output of the database to calculate the Class 5b total expected cost.

As the projects move into preparatory activities or become actionable, TNSPs typically produce Class 5a or 4 estimates as their scope is further refined. In some instances, projects will be delivered in stages, which allows early project stages to be funded and progressed prior to late project stages. This approach allows time for the full project estimate to be further developed before funding is allocated.

While the primary use of the Transmission Cost Database is to produce Class 5b or 5a estimates for future ISP projects, it will also be used to cross-check estimates received from TNSPs, to ensure consistency. This process is discussed further in Section 2.3.

AEMO includes all committed and anticipated projects in all future states of the world, in accordance with the AER's Cost Benefit Analysis Guidelines²¹. Because of this, the capital cost for committed and anticipated projects is not part of the ISP modelling process (similar to the capital cost of existing generation and transmission). Committed and anticipated projects are therefore not described in detail in this report.

2.2 Transmission Cost Database

The Transmission Cost Database was produced in response to stakeholder feedback on the 2020 ISP. AEMO commissioned the Transmission Cost Database to provide increased transparency and accuracy of estimates of costs of future ISP projects, thereby enhancing the ISP outcomes and increasing stakeholder confidence in the estimates. Regular updates of the Transmission Cost Database are required to ensure the currency of the future ISP project cost estimates, and to incorporate the experience of current RIT-T projects into these updates. Section 2.2.3 provides information about the 2023 update to the Transmission Cost Database.

The Transmission Cost Database is comprised of a Cost and Risk Data workbook, containing all the fundamental components used to compile a project cost estimate, and a cost estimation tool with an interactive 'Dashboard' containing algorithms that processes the user inputs and selection choices.

²¹ At <https://www.aer.gov.au/system/files/AER%20-%20Cost%20benefit%20analysis%20guidelines%20-%202025%20August%202020.pdf>.

As outlined in Section 2.2.2, the Transmission Cost Database is intended for use by AEMO to generate Class 5a/b cost estimates for conceptual future ISP projects (or Class 4 in limited circumstances). It is not intended to produce more advanced estimates, as the breakdown of components is not sufficiently detailed. The Transmission Cost Database has been published to allow stakeholders to access the detail within the cost estimates, when assessing and providing feedback during the consultation.

2.2.1 Cost estimate components and treatment of risk

For the purposes of the Transmission Cost Database, cost estimates are broken down into several components, which are described in the following sections:

- Building blocks and baseline cost.
- Adjustments for project specific attributes.
- Risk allowance.
- Indirect costs.

Building blocks and baseline cost

Cost estimates are typically initiated by defining the quantities of certain 'building blocks' or plant/equipment items and multiplying these by the unit cost per item (such as \$/km of overhead line or cost of a 500/330 kilovolt [kV] transformer). The list of building blocks required is developed by defining the scope of work required to deliver the project's objectives, and is the outcome of engineering design. The sum of the building block costs is the baseline cost.

Adjustments for project specific attributes

Building block costs will vary depending on many project-specific variables. It is therefore necessary to adjust the basic unit costs to take account of these factors. Building block adjustment factors are built into the Transmission Cost Database for selection by the user. They are based on past project data, and include the complexity of the project, its location, the type of terrain involved, and environmental factors. For large projects where a certain factor may change over the length of a transmission line, the project is broken into 'network elements' which can fit within a given selection. The selected adjustment factors are made transparent to stakeholders by listing them in each project table in Section 3 and Section 4 of this report. In addition, the numerical and percentage value of each adjustment factor is presented in the detailed output file for each project²².

Risk allowance

As estimates become more accurate, the quantities (scope) typically increase. Unit costs also tend to increase with design definition. The Transmission Cost Database accounts for these increases by defining two risk types:

- Known risks – where risks are identified but the ultimate value of the risk is not known.
- Unknown risks – where the risk has not been identified but industry experience shows that in the course of major projects these can occur. With benefit of hindsight, such risks are not considered fully at the time of estimate preparation.

²² Consultation material is available at <https://aemo.com.au/consultations/current-and-closed-consultations/2023-transmission-expansion-options-report-consultation>.



Indirect costs

Indirect costs represent the project owner’s internal costs. They represent all costs not covered by the contractors or suppliers.

2.2.2 Cost estimate progression

Figure 9 illustrates conceptually the cost structure used by AEMO. The relative heights of the bars in this figure are indicative and will vary according to individual project details. The adjusted baseline costs are shown as “known costs”. Known risk allowances, unknown risk allowances and indirect costs are added to the known costs to form the expected project cost. The known costs increasingly become a larger component of the total cost estimate, while risk allowances decrease as the design progresses. The expectation is that unknown risks will reduce to near zero as the project advances through delivery to completion.

Figure 9 Cost estimate summary breakdown from Class 5b to Class 1

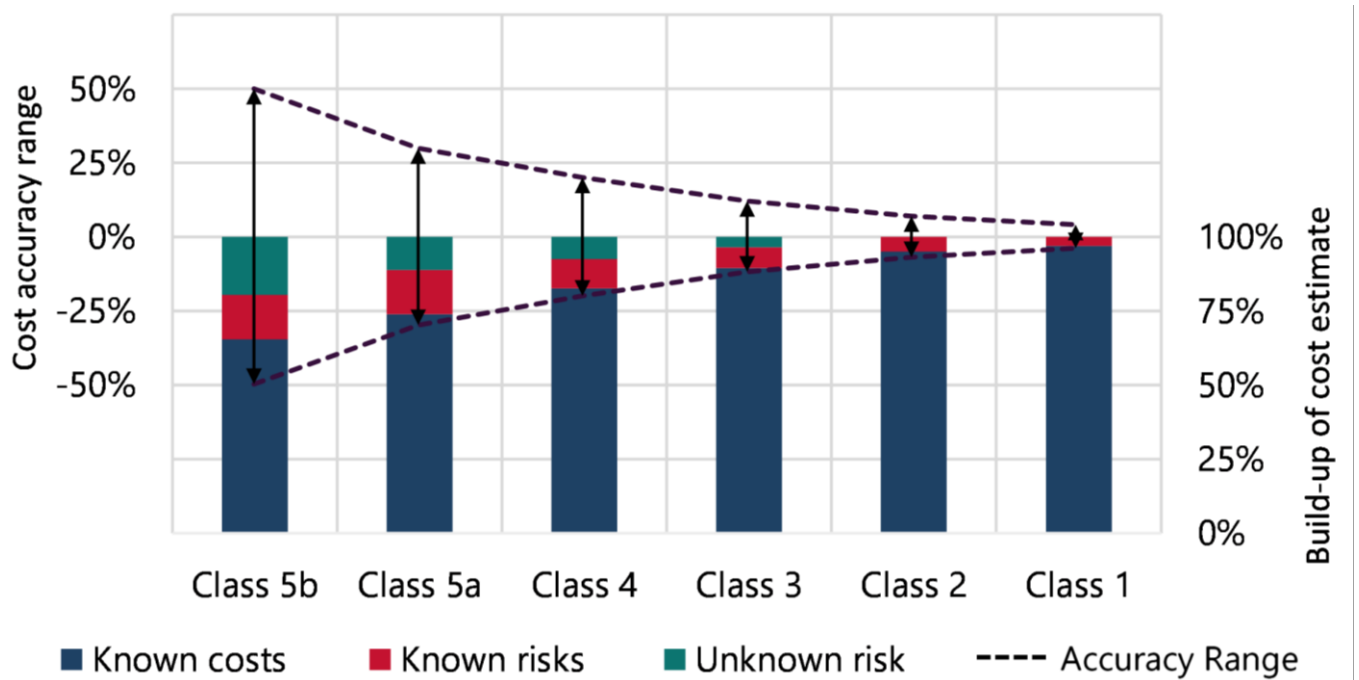

Unknown risk allowances are intended to be used in the Transmission Cost Database for projects at RIT-T or earlier stages. The AER’s guidance note on the regulation of actionable ISP projects states an expectation that unknown risks should not be included at the Contingent Project Application (CPA) stage, and that TNSPs should undertake activities to identify all risks prior to submission of the CPA²³. This may or may not be possible for projects depending on the scope; for example, if involving a transmission line, the route is unlikely to be able to be determined to the required level at an early stage of the project. This is one reason a project may be delivered in stages, allowing early project stages to be funded and progressed prior to late project stages as discussed earlier.

²³ See <https://www.aer.gov.au/networks-pipelines/guidelines-schemes-models-reviews/regulation-of-large-transmission-projects>.

It may be helpful to note that TNSPs do not receive approval for revenue recovery for a project until the CPA is approved by the AER, and therefore the estimates produced for ISP modelling at earlier stages will have broader accuracy bands than that required for the CPA.

Class 5a/5b Definition

As discussed in Section 2.1, AEMO introduced sub-categories within Class 5 to transparently reflect the range of estimates and accuracies that are available within the Australian regulated electricity sector.

These are defined in Table 7, with further explanation below.

Table 7 Class 5 estimate sub-categories

Class	Definition	Unknown risk allowance ^A	Accuracy ^B
Class 5b	Concept level scoping with no site-specific review or TNSP input	Up to 30%	±50%
Class 5a	Screening level scoping including high level site-specific review and TNSP input	Up to 15%	±30%

A. Unknown risk allowance defined as a percentage of the total network element cost (which does not include indirect costs).

B. Accuracy bands have been derived statistically, such that 80% of project estimates should fall within these limits. It is therefore expected that, across a large sample of projects, approximately 20% of them will fall outside of these bands.

The AACE International methodology typically contains accuracy bands which are skewed to the positive side, reflecting higher likelihood of cost increases than decreases as the estimate progresses. The Transmission Cost Database has been designed to include an average allowance for unknown risks which offsets the adjusted building block estimate, such that the ‘total expected cost’ resulting from the Transmission Cost Database can be used as the mid-point of a symmetrical accuracy band for ISP modelling purposes – see Section 2.1.1 for more information.

In this approach, the higher up-side risk of cost increases is reflected directly in a higher cost estimate with symmetrical accuracy bands, rather in skewed accuracy bands. In Figure 9, if the up to 30% unknown risk factor were omitted from the Class 5b estimate, the upper and lower bounds of the estimate would be more aligned with the AACE’s asymmetrical accuracy band for a Class 5 estimate.

The Transmission Cost Database is currently designed to produce Class 5a and Class 5b estimates. The accuracy of the Class 5a estimates produced by the Transmission Cost Database is approximately ±30%, with an unknown risk allowance of up to 15%. This was determined by GHD using statistical analysis of current major transmission network projects as they progressed from screening stage scope definition to CPA – further detail on this analysis is provided in the GHD report²⁴. Accuracy bands have been derived statistically, such that 80% of project estimates should fall within these limits. It is therefore expected that, across a large sample of projects, approximately 20% of them will fall outside of these bands. The accuracy of the Class 5b estimate produced by the Transmission Cost Database is estimated to be ±50%, with an average unknown risk allowance of up to 30%²⁵. Importantly, AEMO also escalates future project costs on top of these estimates. This way, it can also help quantify some of the additional risks to the project estimate.

²⁴ At <https://aemo.com.au/energy-systems/major-publications/integrated-system-plan-isp/2022-integrated-system-plan-isp/current-inputs-assumptions-and-scenarios>.

²⁵ The up to 30% uplift to account for unknown risk in Class 5b estimates is based on the best evidence available to AEMO at the time of publishing the 2023 *Transmission Expansion Options Report*. The value is based on analysis of 22 transmission network projects in 2021. AEMO engaged GHD to conduct this analysis. AEMO has not identified new evidence to inform a change to the value at this stage.



Transmission Cost Database detailed structure and content

The Transmission Cost Database consists of two separate Excel files:

- A Cost and Risk Data workbook containing all the fundamental components used to compile a project cost estimate.
- A cost estimation tool with interactive 'Dashboard' containing algorithms that processes the user inputs and selection choices.

To estimate costs, the user selects plant items from lists of categories and sub-categories, and applies appropriate adjustment factors and risks. The selection choices are processed by the algorithms within the estimation tool, producing the expected project cost.

The Transmission Cost Database cost estimation tool is available for stakeholder use and contains a complete copy of the Cost and Risk Data. A detailed user manual is also provided – these files, along with instructions on how to download and run the tool, are available on the AEMO website²⁶. Full details of the Transmission Cost Database construction including cost and risk data sources are given in GHD's report²⁷, as well as Mott Macdonald's report on the 2023 update of the Transmission Cost Database²⁸.

2.2.3 Update of the AEMO Transmission Cost Database

AEMO's Transmission Cost Database was developed in 2021 and was first published alongside the 2021 Transmission Cost Report. The Transmission Cost Database is a tool which allows AEMO to develop cost estimates for future ISP network expansion options and can be used by external parties to develop conceptual cost estimates for potential transmission augmentations. AEMO updates the Transmission Cost Database to ensure that the ISP is prepared using up to date transmission cost estimate information. An update may include updating cost estimates for individual equipment or cost component building blocks, revision of attributes and risk allowances, and inclusion of additional selections to ensure the tool remains relevant in the changing technology landscape.

In 2022, AEMO engaged independent consultant Mott MacDonald to deliver a suite of updates to the Transmission Cost Database²⁹. These updates improve the alignment of the Transmission Cost Database with TNSPs' best practice in conceptual cost estimates for transmission infrastructure and improve the accuracy of the tool through review of the project attribute and risk factors. The work included an update to the costs of all building blocks in the database (for example, a transformer) so they more accurately reflect the actual costs faced by TNSPs as of June 2022. Significant TNSP engagement was necessary to update the Transmission Cost Database as many transmission projects have progressed through the RIT-T process since the original development of the database.

The updated Transmission Cost Database is available for download from AEMO's website³⁰.

An important result of this update is that project cost estimates produced using the updated Transmission Cost Database are, dependent on scope, approximately 30% higher (in real terms). These real cost increases reflect

²⁶ AEMO. Transmission Cost Database version 2.0. At <https://aemo.com.au/consultations/current-and-closed-consultations/2023-transmission-expansion-options-report-consultation>.

²⁷ At <https://aemo.com.au/energy-systems/major-publications/integrated-system-plan-isp/2022-integrated-system-plan-isp/current-inputs-assumptions-and-scenarios>.

²⁸ Refer to Attachment 1 – *Transmission Cost Database Update Final Report July 2023*. Mott MacDonald.

²⁹ Refer to Attachment 1 – *Transmission Cost Database Update Final Report July 2023*. Mott MacDonald.

³⁰ Registration for the Transmission Cost Database tool is available at <https://forms.office.com/r/YbmiGc24TP>.

cost pressures that are specific to the transmission industry and represent an increase beyond economy-wide inflation. AEMO considers it pertinent to note that the nominal increase in project costs reflected in the updated Transmission Cost Database would additionally include cumulative inflation from December 2020 to June 2022; this was 7.6%^{31,32} (rounded).

2.3 Comparison of TNSP and AEMO cost estimates

The purpose of this section is to outline AEMO's approach to reviewing cost estimates provided by TNSPs such that they are complete and consistent, and to validate that AEMO's transmission cost estimation process is reasonable.

AEMO has broadly adopted the AACE standard for the ISP. TNSPs each have their own project cost estimation process that has evolved through the development of their respective transmission project portfolios.

A number of typical project characteristics influence these processes, including:

- The technical scope of projects.
 - Inclusion of transmission lines, station works or cabling.
 - Degree of risk definition throughout the maturity of each project.
- The degree of information available at the earliest stage of each project.
- Recent experience in procuring sites, land, and easement corridors.

2.3.1 Objectives

AEMO engaged with each TNSP to establish a process to ensure cost estimates are aligned across all projects in AEMO's ISP modelling. The objectives of this engagement were as follows:

- Improve transparency of how TNSPs develop estimates for projects, including the different stages of cost estimation, inclusion of risk allowances, and accuracy that is achieved at each stage.
- Develop a common definition of work required to meet each estimate class for transmission projects.
- Develop a process to align TNSP estimates and enable a consistent approach for inclusion of risk.
- Validate that AEMO's transmission cost estimation process is reasonable.

2.3.2 Checklist development

AEMO engaged with the AER and TNSPs to develop a checklist which reflects various aspects of a project at different stages of maturity.

For example, one indicator of the amount of design that has been completed on a project is the level of documentation that has been prepared. This aspect forms one line on the checklist; 'Level of Documentation' can be described as:

³¹ Reserve Bank of Australia. *Statement on Monetary Policy – August 2021*. At <https://www.rba.gov.au/publications/smp/2021/aug/inflation.html>.

³² Reserve Bank of Australia. *Statement on Monetary Policy – August 2022*. At: <https://www.rba.gov.au/publications/smp/2022/aug/inflation.html>.

- Class 5a/b – conceptual single line diagram.
- Class 4 – detailed single line diagram.
- Class 3/2/1 – ‘For Construction’ electrical and civil drawings.

The engagement process focused on discussions with TNSPs about cost estimation processes, project stages, and stage definitions. The resulting checklist is shown in Appendix A1, and was used to approximate the class of each estimate that was provided by TNSPs.

2.3.3 Review and adjustment process

Estimates received from TNSPs were reviewed in accordance with this three-stage cost classification process:

1. Classification and preliminary screening of cost estimates:
 - a) TNSP provided completed checklist responses for each project option (ahead of providing cost estimate).
 - b) AEMO approximated the class of the estimate for that project option. This was done by reviewing the set of TNSP responses against the AEMO checklist. The assigned class was that which had the highest correlation against the responses.
 - c) AEMO reviewed the TNSP’s allocation for unknown risks against the expectation for the assigned class (See Section 2.2.2).
 - d) AEMO worked with the TNSP to resolve any missing cost components or differences in risk allocation treatments.
2. Review of cost estimates:
 - a) TNSP provided cost estimate for each project option.
 - b) AEMO estimated cost in parallel, using the Transmission Cost Database.
 - c) AEMO compared estimates and worked with the TNSP to resolve or understand any significant differences in cost components or risk allowances. Importantly, as discussed in Section 2.2, the Transmission Cost Database is used for developing estimates for conceptual Class 5 projects. When used for comparing against TNSP estimates, it is used to enable a further understanding of the breakdown of differing costs as given by the TNSP and for further benchmarking of the tool itself.
3. Final alignment of cost estimates:
 - a) AEMO carried out final review of TNSP updated estimate.
 - b) Where sufficient information was not provided to AEMO, or where missing or insufficient allowance was made for cost components or risk, AEMO considered requirement for an additional allowance based on the Transmission Cost Database.

2.3.4 Review outcomes

AEMO received completed TNSP checklist responses and TNSP cost estimates for actionable projects and projects with preparatory activities from most TNSPs during June 2023. Table 8 compares the costs received from TNSPs for preparatory activities and actionable ISP projects against the costs estimated by AEMO’s Transmission Cost Database.

Table 8 Comparison of TNSP and AEMO cost estimates

Project	Expected costs (\$ billion)		Review outcome ^A	Estimate class	
	TNSP estimate	AEMO estimate		TNSP estimate within AEMO accuracy band?	TNSP
Preparatory activities					
QNI Connect (500 kV – NSW works)	2.60 (±50%)	2.03 (±50%)	✓	5	5b
QNI Connect (330 kV single-circuit – NSW works)	0.93 (±50%)	0.87 (±50%)	✓	5	5b
QNI Connect (330 kV double-circuit – NSW works)	1.21 (±50%)	1.04 (±50%)	✓	5	5b
Sydney Southern Ring	1.55 (-30% to +40%)	1.19 (±50%)	✓	4-5	5b
QNI Connect (500 kV – QLD works)	2.66 (±50%)	1.89 (±50%)	✓	5	5b
QNI Connect (330 kV single-circuit – QLD works)	0.96 (±50%)	0.82 (±50%)	✓	5	5b
QNI Connect (330 kV double-circuit – QLD works)	1.31 (±50%)	1.04 (±50%)	✓	5	5b
Darling Downs REZ Expansion (Stage 1)	0.029 (±50%)	0.039 (±50%)	✓	5	5b
Mid-North SA REZ	0.416 (±50%)	0.522 (±50%)	✓	5b	5b
South East SA REZ	0.034 (±50%)	0.038 (±50%)	✓	5b	5b
South West Victoria REZ Option 1	0.064 (±30%)	0.064 (±30%)	✓	5a	5a
South West Victoria REZ Option 1A	0.725 (±30%)	0.725 (±30%)	✓	5a	5a
South West Victoria REZ Option 1B	1.013 (±30%)	1.013 (±30%)	✓	5a	5a
South West Victoria REZ Option 1C	1.372 (±30%)	1.372 (±30%)	✓	5a	5a
South West Victoria REZ Option 2A	0.617 (±30%)	0.617 (±30%)	✓	5a	5a
South West Victoria REZ Option 2B	0.803 (±30%)	0.803 (±30%)	✓	5a	5a
South West Victoria REZ Option 3A	1.076 (±30%)	1.076 (±30%)	✓	5a	5a
South West Victoria REZ Option 3B	1.324 (±30%)	1.324 (±30%)	✓	5a	5a
Actionable ISP projects					
HumeLink	4.892 (-5% to +12%)	4.165 (±50%)	✓	3	5b
VNI West	3.614 ^B (±30%)	3.331 (±30%)	✓	4	5a
Marinus Link Stage 1 (HVAC) ^C	0.64 (±15%)	0.59 (±30%)	✓	4	5a
Marinus Link Stage 2 (HVAC) ^C	0.11 (±15%)	0.12 (±30%)	✓	4	5a

- A. This column indicates whether AEMO's cost forecasting approach is fit-for-purpose when compared against the latest cost estimates from TNSPs. This shows a level of confidence that AEMO's forecasting approach is fit-for-purpose for estimating future conceptual projects as part of this report.
- B. This is the 2023 cost of the VNI West Project without Western Renewables Link project, this was calculated from the nominal 2021 dollars cost of \$3.499 billion presented in the PACR.
- C. AEMO did not have sufficient independent cost data to estimate the HVDC portion of MarinusLink, hence only the HVAC portion was used for the comparison. The cost estimates were provided by Marinus Link from the Project Marinus PACR 2021. AEMO escalated these costs from 2021 dollars to 2023 dollars.

2.4 Estimating operational expenditure

To estimate the operational expenditure (OPEX) for transmission projects, 1% of the total capital cost per annum is assumed as operation and maintenance cost for each transmission project. AEMO determined this approach following a review of TNSP revenue determinations, as outlined in the accompanying consultation summary report.

2.5 Landholder payment schemes

AEMO recognises the important role of communities that host transmission lines and infrastructure, and the importance of land owners who host transmission being fairly compensated. Landholder payment schemes, which are additional to landholders' compensation, have been announced in various states, including:

- **New South Wales** – under the Strategic Benefit Payments Scheme³³ established in October 2022 for major new transmission projects, private landowners in New South Wales will be able to receive \$200,000 per kilometre of transmission line hosted (in real 2022 dollars), paid out in annual instalments over 20 years. The Strategic Benefit Payments Scheme Policy Paper also highlights that “these benefit sharing payments will be made separately, and in addition to, the existing requirement to pay compensation to landowners for transmission easements under the *Land Acquisition (Just Terms Compensation) Act 1991*”³⁴.
- **Queensland** – Powerlink’s SuperGrid Landholder Payment Framework³⁵ will apply for landholders and neighbours for easements for new transmission lines from May 2023. Landholders whose properties are traversed by an easement are entitled to payments under the Acquisition of Land Act 1967 (ALA). To represent this framework, AEMO will apply a cost of \$230,000 per km of new transmission based on advice from Powerlink, paid out in a lump sum – noting that landholders can decide between a lump sum or annualised payments.
- **Victoria** – in February 2023 the Victorian Government announced³⁶ that it will make payments to landholders for hosting new transmission projects, totalling \$200,000 per kilometre of transmission line hosted and paid in annual instalments over 25 years. These new payments will apply to ISP and Victorian renewable energy zone (REZ) transmission projects and are separate to any payments under existing arrangements for transmission easements under the *Land Acquisition and Compensation Act 1986*³⁷.

AEMO will include announced landholder benefit payment schemes listed in this section in the ISP cost benefit analysis. AEMO will joint plan with the responsible TNSP or jurisdictional body to estimate a percentage of the total new transmission circuit line length which can prudently be assumed to be held by private landholders who will be eligible for these payments.

³³ EnergyCo. ‘Strategic benefit payments scheme’ web page. At <https://www.energyco.nsw.gov.au/community/strategic-benefit-payments-scheme>.

³⁴ New South Wales Government, 2022, *Strategic Benefit Payments Scheme policy paper*, October 2022, p. 5. At <https://www.energyco.nsw.gov.au/sites/default/files/2022-10/policy-paper-strategic-benefit-payments-scheme.pdf>.

³⁵ Powerlink’s SuperGrid Landholder Payment Framework, <https://www.powerlink.com.au/sites/default/files/2023-05/SuperGrid-Landholder-Payment-Framework.pdf>

³⁶ New payments for landholders who host new transmission. At <https://www.energy.vic.gov.au/renewable-energy/transmission-and-grid-upgrades>.

³⁷ *Land Acquisition and Compensation Act 1986* (Victoria). At <https://www.legislation.vic.gov.au/in-force/acts/land-acquisition-and-compensation-act-1986/054>.

For the purposes of providing the ISP model with conceptual estimates in order to develop the ODP, each option will have a total new circuit length and an estimated percentage of the new circuit length that traverses through private land. This 'private land factor' will be determined through joint planning with TNSPs. For further detail on these new circuit lengths applied please refer to the augmentation options in the IASR Workbook³⁸.

2.6 Economic, social and environmental costs and benefits

The high-voltage transmission infrastructure plays a crucial role in connecting all those who produce and consume electricity across the NEM – from Port Douglas in Queensland to Port Lincoln in South Australia and across the Bass Strait to Tasmania. Within the context of the ISP, the high-voltage infrastructure, including towers, conductors, and substations, is critical to affordably meeting Australia's long-term energy reliability and decarbonisation goals.

The planning and delivery of transmission infrastructure relies on participation from a wide range of stakeholders. AEMO has an important role in producing the ISP – it presents a roadmap to help guide Australia's energy transition, and many large transmission infrastructure projects are first conceptualised in the ISP. However, there are also limitations in the granularity of information in the ISP. Transmission projects are inherently complex and must be refined, redesigned, rescheduled and potentially cancelled as more information becomes available.

AEMO acknowledges that high-voltage infrastructure plays a critical role in the energy transition, but also can have localised impacts to host landowners, communities and the broader environment. Planning the future of the grid is also a highly regulated process, and it is inter-related and dependent on obtaining planning and environmental approvals under relevant state and federal legislation.

The regulatory framework

The ISP is carried out in compliance with the National Electricity Rules (NER) and AER guidelines. In accordance with these requirements, AEMO considers the cost of construction, maintenance, and operation of any network option, including compliance with laws, regulations, and administrative requirements. In relation to regulated network augmentations, only those matters which can be costed can be included³⁹ within the cost-benefit analysis that AEMO and TNSPs are required to undertake.

This includes aspects such as the cost of compliance with any planning and environmental legislation. For example:

- If a government requires a network project to secure a biodiversity offset to manage the impact of removing native vegetation, the cost of providing that offset will be incorporated into the project estimate.
- If a project requires new easements or substations, the cost of assembling the required land and easements will be incorporated into the project estimate.
- If the route of a project needs to avoid an area of environmental concern, the additional cost will be incorporated into the project estimate.

³⁸ Consultation materials for the 2023 IASR are available at <https://aemo.com.au/en/consultations/current-and-closed-consultations/2023-inputs-assumptions-and-scenarios-consultation>.

³⁹ For further explanation of the cost estimation undertaken as part of the ISP process, see the AER publication 'Cost Benefit Analysis Guidelines' section 3.3.3 (Valuing Costs), at <https://www.aer.gov.au/system/files/AER%20-%20Cost%20benefit%20analysis%20guidelines%20-%202025%20August%202020.pdf>.

- If an overhead transmission option does not comply with planning requirements or environmental legislation, underground options may be considered.

Where an impact, or cost, is not included as a relevant consideration in the regulations, the regulations do not permit these matters to be considered, which includes matters like broader social and environmental impacts⁴⁰. Similarly, the regulations do not allow consideration of wider benefits of building or maintaining transmission infrastructure such as increased regional jobs, local manufacturing, utilisation of local contractors, training and apprenticeships, or economic opportunities unlocked or facilitated by the projects.

Importantly, while the regulatory process that underpins the ISP and any future RIT-T is undertaken on a cost benefit analysis, these are only some of the preliminary steps that occur before each project obtains the necessary planning and environmental approvals. Broader social and environmental impacts are considered as part of the relevant jurisdictional environmental and planning assessment processes.

Overhead and underground options

The expansion of the transmission network is essential to provide access to the existing transmission network for renewable generation in remote areas and to increase the capability to share electricity between regions. In some cases, expansion within the existing transmission network is also necessary to supply major load centres.

Overhead lines are often an economic, flexible, and responsive design choice for augmenting the high-voltage transmission network. These lines represent the vast majority of the Australian transmission network and have reliably served the community for many years. In some certain circumstances, alternate design or technology choices may be feasible.

While AEMO makes conceptual design assumptions in the ISP, projects that become actionable will progress through the RIT-T. In this process, the TNSP must consider a range of feasible network options to meet the identified need, including credible alternate designs or technologies. These may include:

- Alternate structure designs, including monopoles, guyed towers, and a variety of lattice towers.
- Alternate design methodologies, including insulated conductors or cables.
- Alternate construction methodologies, including helicopter-stringing and direct drilling.
- Alternate technologies, including high-voltage alternating current (HVAC) and high-voltage direct current (HVDC).
- Non-network solutions, including battery services that obviate the need to build new network.

Building overhead transmission lines may not always be the cheapest method to augment the network. Not every alternative will be credible or feasible given the objectives and economics of the individual project. Each TNSP will consider a wide range of options as the projects progress.

In the absence of detailed designs, AEMO has made the following assumptions for considering undergrounding in areas where overhead transmission lines are not expected to be technically feasible or are not compliant with planning requirements or environmental legislation:

⁴⁰ The CBA Guidelines (pages 18 and 21) require AEMO to exclude in any analysis under the ISP, any cost or benefit which cannot be measured as a cost to generators, DNSPs, TNSPs or consumers of electricity. At <https://www.aer.gov.au/system/files/AER%20-%20Cost%20benefit%20analysis%20guidelines%20-%2025%20August%202020.pdf>.

- HVAC underground cable is technically feasible for shorter lengths of transmission (from 20 km for 500 kV to up to approximately 100 km for lower transmission voltages). Beyond these lengths, AC cables at high voltage level will be subject to very large charging currents, requiring significant reactive compensation and design considerations.
- For HVDC options, longer lengths of underground cable are likely to improve commercial feasibility relative to overhead options.
- Direct burial of cables is cheaper than tunnel installation, but is only suitable in non-urban areas. Built up areas will typically require tunnel-installed cable to avoid existing infrastructure. Maintenance is easier on tunnel-installed cables due to simpler access of the cable.

The Transmission Cost Database includes cost estimates for overhead transmission lines and underground cables, both of which vary significantly with voltage level and capacity.

Figure 10 shows a comparison of these cost estimates for given voltage levels and power transfer capacities. The HVAC option is included as a reference point. The costs of underground cables are approximately four to 20 times higher than overhead lines. Direct buried cables are at the lower end of this range, while tunnel-installed cables are at the upper end.

Figure 10 Indicative unit cost multiplier from HVAC overhead lines to HVAC underground cables

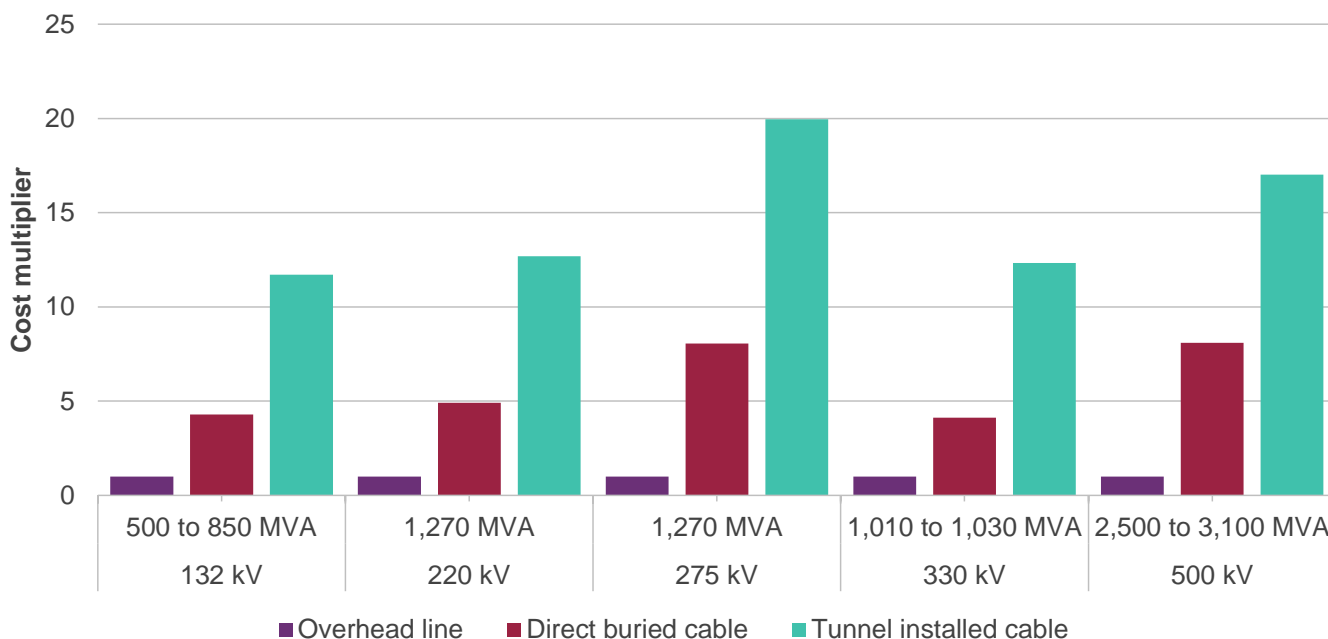

Notes:

- This chart shows cost factor increases relative to the respective overhead option on a generic unit cost basis. Underground 500 kV HVAC options cost more than 275 kV HVAC options, but the cost factor increase is higher when undergrounding a 275 kV HVAC option compared to undergrounding a 500 kV HVAC option.
- This chart has been prepared using AEMO’s Transmission Cost Database and may not provide an appropriate comparison for all projects due to local circumstances.
- This cost comparison is indicative of the variable per unit cost of overhead lines and underground cables. The total project cost is sensitive to factors such as terrain, geotechnical constraints, and fixed cost factors associated with transition stations.
- Tunnel installed cable design is most applicable to underground cable projects in urban areas while direct buried cable can be suitable for projects in rural or remote areas. For greenfield transmission projects in rural or remote areas it is appropriate to compare overhead with direct buried cable.

2.7 Market impacts on transmission costs

There is the potential that delivery of multiple coincident projects will impact transmission costs, both in labour and materials. AEMO has previously partnered with Infrastructure Australia for the 2021 *Market Capacity of Electricity Infrastructure* report⁴¹ and the 2022 *Market Capacity of Electricity Infrastructure* report⁴². These reports studied the labour and material requirements to fulfil the NEM-wide generation and transmission projects included in the 2020 and 2022 ISPs. In addition, AEMO partnered with the University of Technology Sydney and RACE for 2030 to specifically examine the volume of labour required to deliver the infrastructure build set out in the 2022 ISP across the scenarios⁴³.

The Transmission Cost Database allows the selection of a known risk, referred to as market activity. The selection of this known risk is intended to reflect the impact on transmission costs of the concurrent delivery of large transmission projects that is attributable to competition for labour and materials. For example, setting this factor to “Tight” applies a 5% uplift to the costs of plant and materials, and labour. This factor will be applied to transmission cost estimates on a case-by-case basis and through extensive joint planning with TNSPs and jurisdictional bodies.

AEMO has amended the ISP Methodology to note that if generation or transmission build in the draft or final ISP is observed to be lumpy, sensitivity analysis could be conducted to assess the impact of limiting infrastructure delivery in the ISP based on supply chain outcomes.

2.8 Projected changes in transmission infrastructure costs over time

In addition to updating the Transmission Cost Database, AEMO has updated its treatment of costs for projects delivered in future years.

In previous ISPs, it was assumed that the costs of transmission network augmentation projects would remain constant in real terms. That is, that costs would increase in line with economy-wide inflation.

For the 2024 ISP, AEMO will use cost forecasts that reflect changes beyond those attributable to economy-wide inflation. This choice was made in recognition of the heightened project delivery costs currently being experienced by the transmission industry (relative to several years ago), and the anticipated impact on costs of a substantial increase in transmission network build, both domestically and internationally.

This section notes the methodology to be used to prepare the forecasts for the transmission cost components, and the approach to be taken to apply them for transmission augmentation projects in the ISP modelling.

2.8.1 Forecasts for transmission cost components

AEMO engaged Mott MacDonald to develop a methodology for forecasting the cost of transmission projects for the period out to 2040, with June 2022 as the reference point. The methodology, and the subsequent escalation

⁴¹ At <https://www.infrastructureaustralia.gov.au/market-capacity-electricity-infrastructure>.

⁴² At <https://www.infrastructureaustralia.gov.au/publications/2022-market-capacity-report#:~:text=Infrastructure%20Australia%20is%20pleased%20to,over%20the%20last%2012%20months>.

⁴³ University of Technology Sydney. *The Australian Electricity Workforce for the 2022 Integrated System Plan: Projections to 2050. Revision 1.* At <https://aemo.com.au/-/media/files/major-publications/isp/2022/supporting-materials/the-australian-electricity-workforce-for-the-2022-isp.pdf?la=en>.

factors from June 2022, can be found in Mott MacDonald's report summarising the Transmission Cost Database update⁴⁴.

Mott MacDonald allocated the components of transmission network projects into nine baskets. The price of goods or services in a particular basket is determined by a weighted mix of economic indices pertaining to that basket⁴⁵. Mott MacDonald then provided a set of escalation factors for each basket over the period to 2040 based on how the underlying indices were expected change. The nine baskets identified were:

- Design, survey and project management.
- Construction works, commissioning and testing.
- Easement and property costs.
- Overhead line.
- Underground cables.
- Switch bays, property site work and building.
- Transformers, reactors and synchronous condensers.
- Secondary systems.
- Switchgear, instrumentation, and converters.

AEMO will take the following approach to apply the escalation factors to transmission augmentation project cost estimates in the ISP:

- **Apply the Mott MacDonald escalation factors until a 'new normal' date for each of the IASR scenarios – 2029-30 for *Step Change* and *Green Energy Exports*, and 2026-27 for *Progressive Change*.**
 - AEMO expects that costs for transmission project resources will increase moderately in real terms for several years, above the increases driven by recent global economic shocks. The cost trajectory over this period reflects an expectation for demand for transmission project resources to grow, and that there may be a material lag before there is a supply-side reaction to elevated prices. The forecasts are simultaneously informed by projections of commodity prices (oil, aluminium, copper and steel). The prices of these commodities are generally projected to fall over time in real terms from the values seen in 2021-22⁴⁶.
 - The choice for 2029-30 in the *Step Change* and *Green Energy Exports* scenarios is informed by a view that delivering a higher rate of transmission build in the period to 2030, to meet interim net-zero emissions targets, would result in a greater imbalance between supply and demand for transmission project resources which may take more time to resolve. This aligns with CSIRO's expectation, as outlined in *GenCost 2022-23*⁴⁷, that capital expenditure for generation projects will take longer to return to similar supply-demand balance to that seen prior to recent economic shocks in the *Step Change* and *Green Energy*

⁴⁴ Mott MacDonald. *AEMO Transmission Cost Database, Building Blocks and Risks Factors Update, Final Report Version 2.0*. July 2023. At <https://aemo.com.au/consultations/current-and-closed-consultations/2023-transmission-expansion-options-report-consultation>.

⁴⁵ As discussed in section 2.3 of Mott MacDonald's report, environment offset costs were not included in the escalation baskets of indices due to the high level of forecasting uncertainty, lack of identification of an appropriate economic index, and insufficient data from which to build an economic model. Instead, environmental offset cost components of transmission augmentation projects will be estimated for each project using the Transmission Cost Database and then escalated consistent with other non-transmission augmentation projects in the ISP cost benefit analysis.

⁴⁶ Office of the Chief Economist and Department of Industry Science and Resources. *Resources and Energy Quarterly March 2023*. May 2023. At <https://www.industry.gov.au/sites/default/files/2023-04/resources-and-energy-quarterly-march-2023.pdf>.

⁴⁷ At <https://www.csiro.au/en/research/technology-space/energy/energy-data-modelling/gencost>.

Exports scenarios, than in the *Progressive Change* scenario. CSIRO has put forward that generation project capital expenditure will return to pre-global economic shock supply-demand balance by 2026-27 in *Progressive Change*, and by 2029-30 in the *Step Change* and *Green Energy Exports* scenarios.

- **Beyond the ‘new normal’ date, plateau all escalation factors except for easement and property costs.**
 - AEMO considers it reasonable to assume that at some point a ‘new normal’ may be achieved, in which transmission project costs cease increasing in real terms. To assume that costs persistently increase in real terms over the whole period to 2039-40 would imply an expectation that the demand for transmission project resources will persistently grow relative to supply, or that there is a substantial resource scarcity. AEMO does not expect that demand for transmission project resources will grow indefinitely, particularly after a period of high global transmission industry activity required to achieve 2030 emissions targets. However, AEMO cannot see the case for assuming that transmission infrastructure costs would necessarily decline to return to the ‘normal’ observed prior to recent global events. As such, AEMO will assume that cost trajectories plateau in real terms, with the exception of property costs as noted below. This approach differs from the approach taken by CSIRO for the GenCost 2022-23 report, given the reasonable assumption that cost reductions due to learning rates can be applied for the newer types of electricity generation such as wind and solar.
 - This assumption will not be applied to property and easement costs, as the supply of land is finite, and there is no capacity for the market to adjust to accommodate higher demand. Instead, AEMO will assume that the costs for land will continue to escalate across the horizon to 2049-50. AEMO has extrapolated the escalation for property and easement costs provided by Mott MacDonald. In its final GenCost 2022-23, CSIRO has adjusted its approach to take the same approach for property cost escalations as is outlined here for transmission, ensuring consistent treatment between transmission and generation property and easement cost forecasts for the ISP.

Across the forecasting horizon, AEMO will adjust the biodiversity offset costs included in the cost estimate so the proportion of biodiversity offset costs to total direct project costs remains the same, consistent with the approach suggested by Mott Macdonald. A specific escalation factor was not identified for biodiversity offset costs.

AEMO considers that this forecasting approach reflects reasonable consideration of a heightened level of demand for transmission project resources, noting that costs have already been elevated substantially by recent global price shocks and that these impacts are reflected in the updated Transmission Cost Database. AEMO acknowledges that the ultimate ‘new normal’ for transmission infrastructure is not yet known and will be highly dependent on international global headwinds, local and international policy, and market changes.

Figure 11 and Figure 12 illustrate the forecast changes for each basket of indices for transmission project costs, to be applied in the ISP. The forecast changes to each basket of indices project minimal real cost changes to transmission plant and materials, which are heavily influenced by commodity and shipping prices, out to 2029-30. There are however notable increases projected for construction, services and property and easement costs which are driven primarily by workforce cost and availability, as well as land value.

Figure 11 Forecast cumulative cost changes for transmission projects: plant, materials, and easement and property costs, in real terms

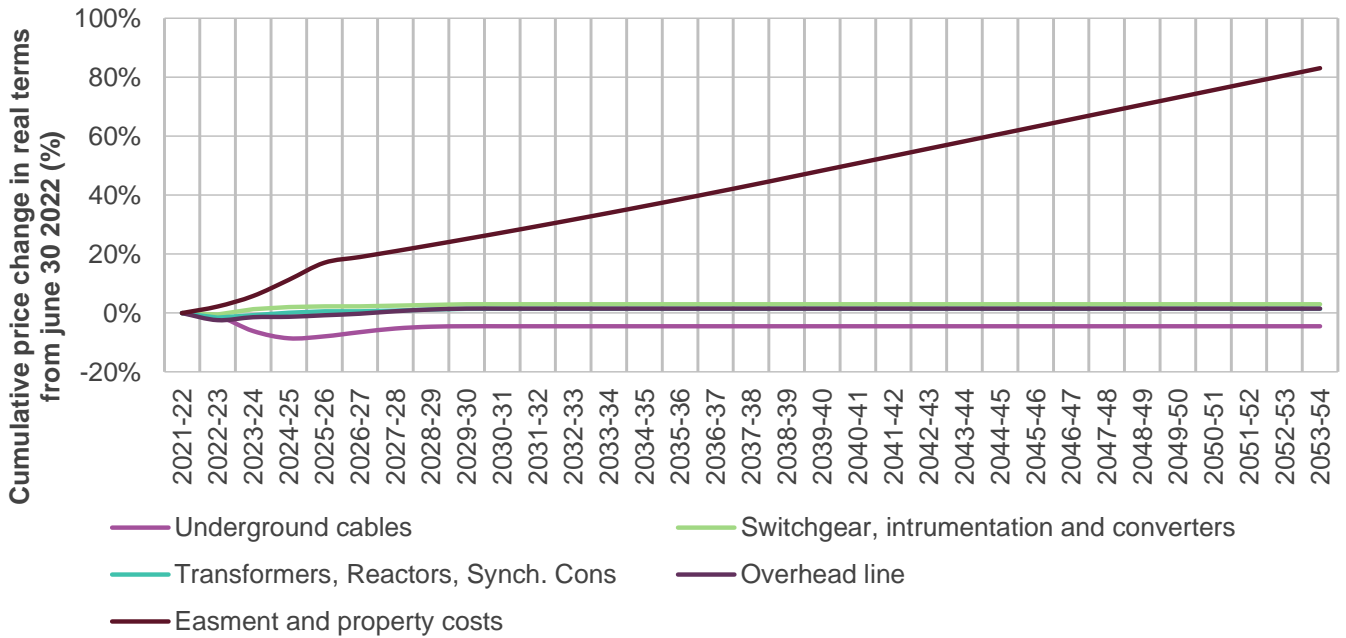

Figure 12 Forecast cumulative cost changes for transmission project cost components: construction, services and secondary (electrical) systems, in real terms

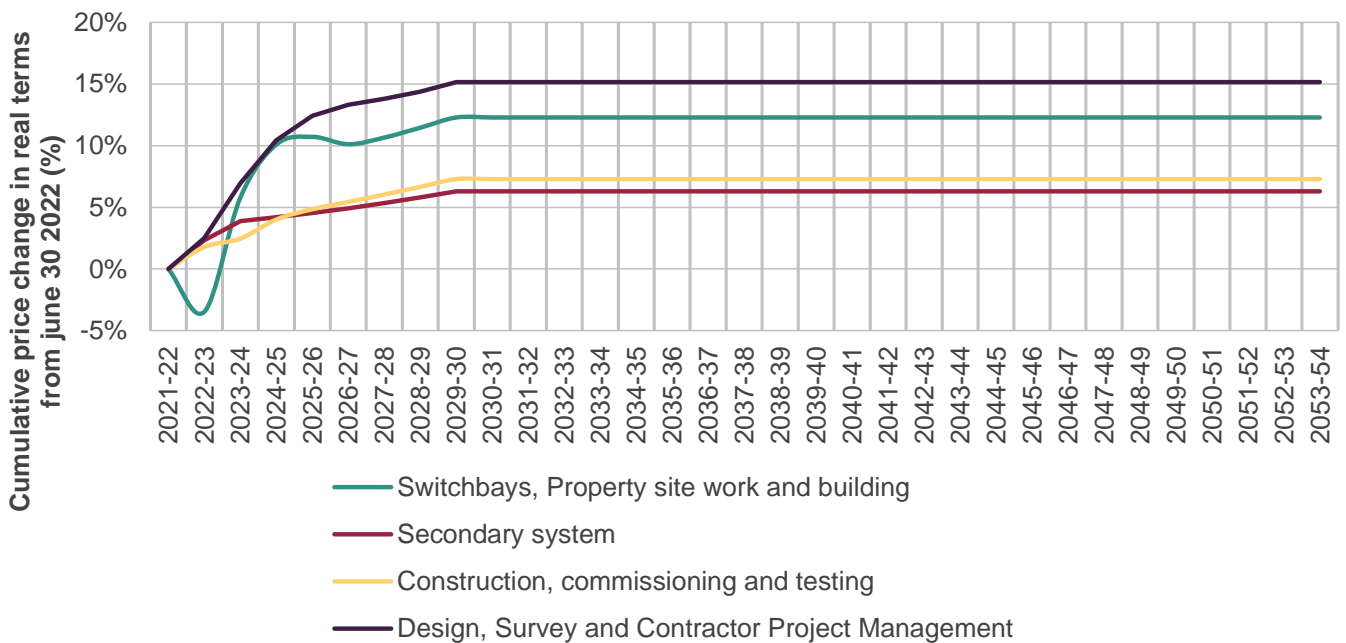
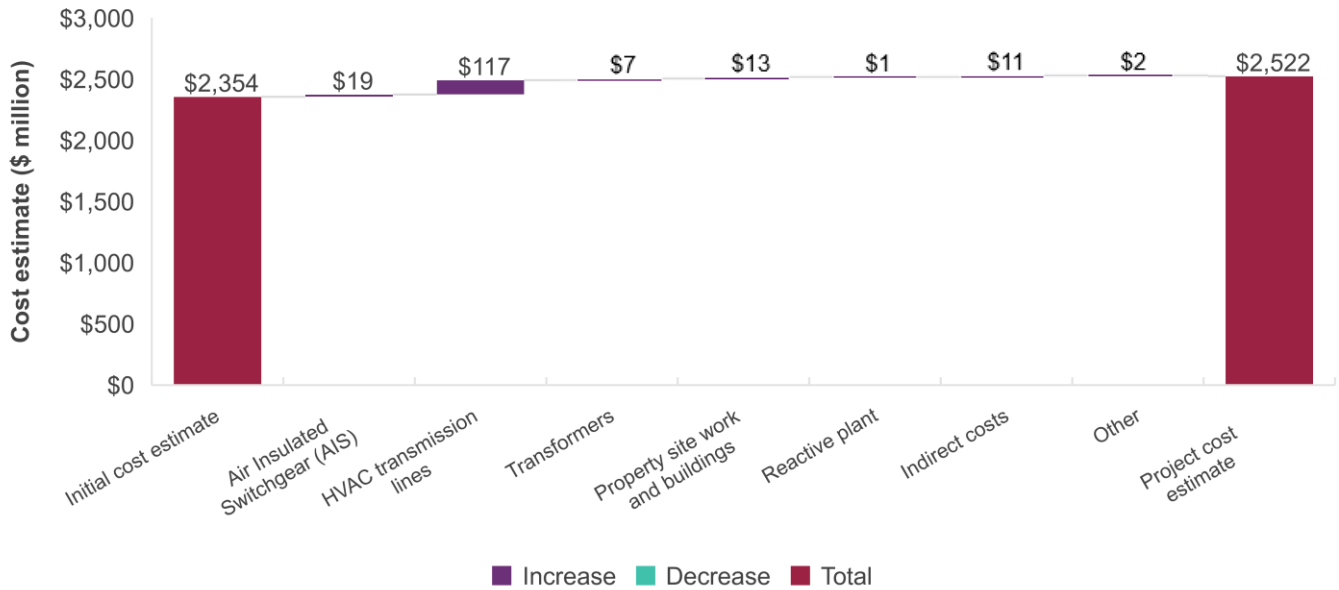

Figure 13 gives an example of the impact of applying escalation factors to a sample project (an augmentation option for the Central Queensland to Southern Queensland flow path). In this example, the largest change is projected for transmission line costs.

Figure 13 Application of transmission cost forecasting methodology to a sample project, in real terms



Note: The scope for the sample project includes 7 x 500 kV transformers, almost 300 km of 500 kV transmission lines, some lower voltage transmission lines, and two phase shifting transformers.

As a result of these forecasts, the real cost difference of projects out to 2029-30 will change based on the composition of network elements that are included in the project. On average, a real cost increase between 8% and 9% is projected by 2029-30, as shown in Figure 14 and Figure 15 for *Step Change* and *Green Energy Export* scenarios, and the *Progressive Change* scenario, respectively.

Figure 14 Forecast average cost changes (real \$2023) for flow path, REZ and generator connection projects, Step Change and Green Energy Export scenarios, 2021-22 to 2053-54

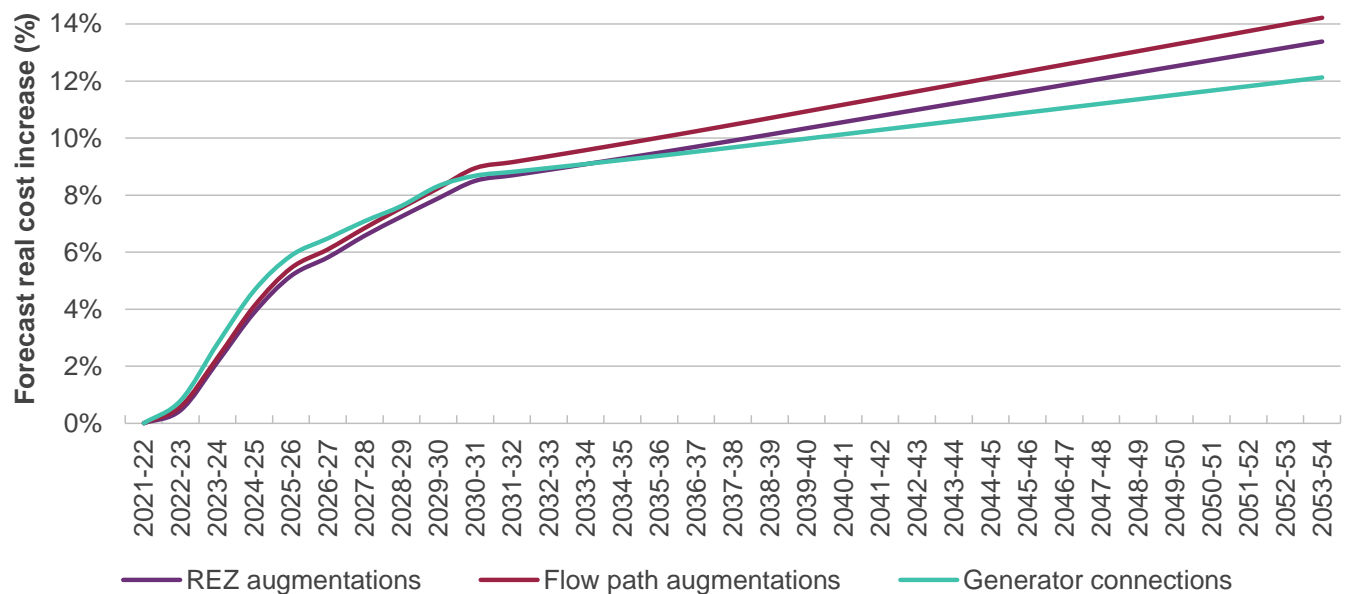

Figure 15 Forecast average cost changes (real \$2023) for flow path, REZ and generator connection projects, Progressive Change scenario, 2021-22 to 2053-54

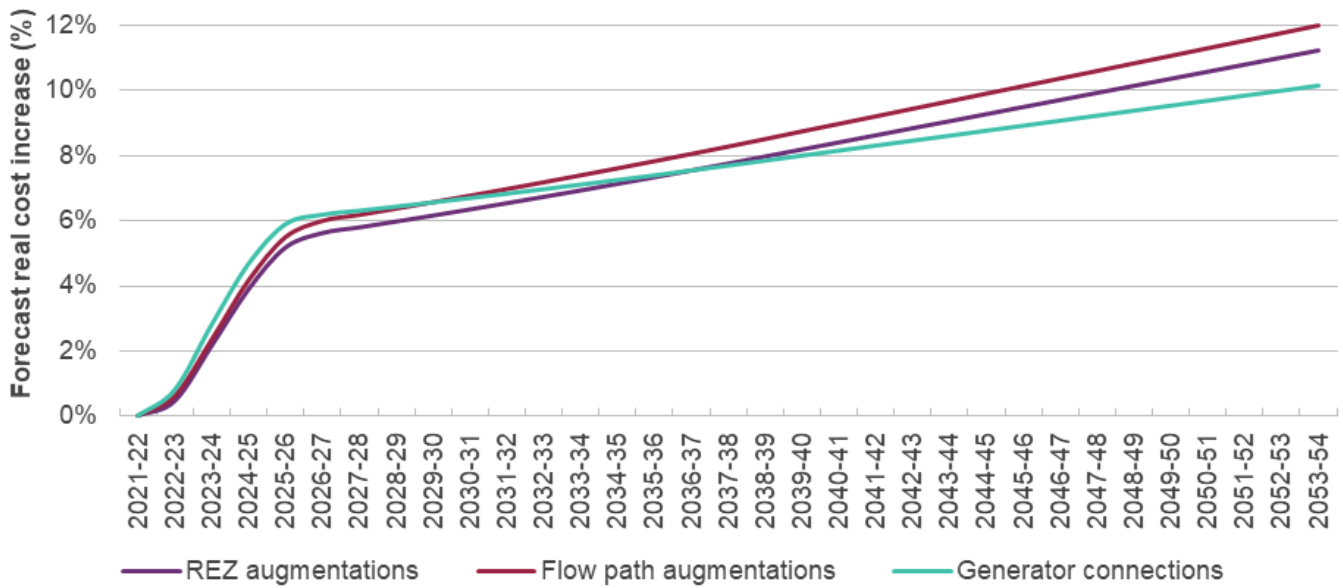
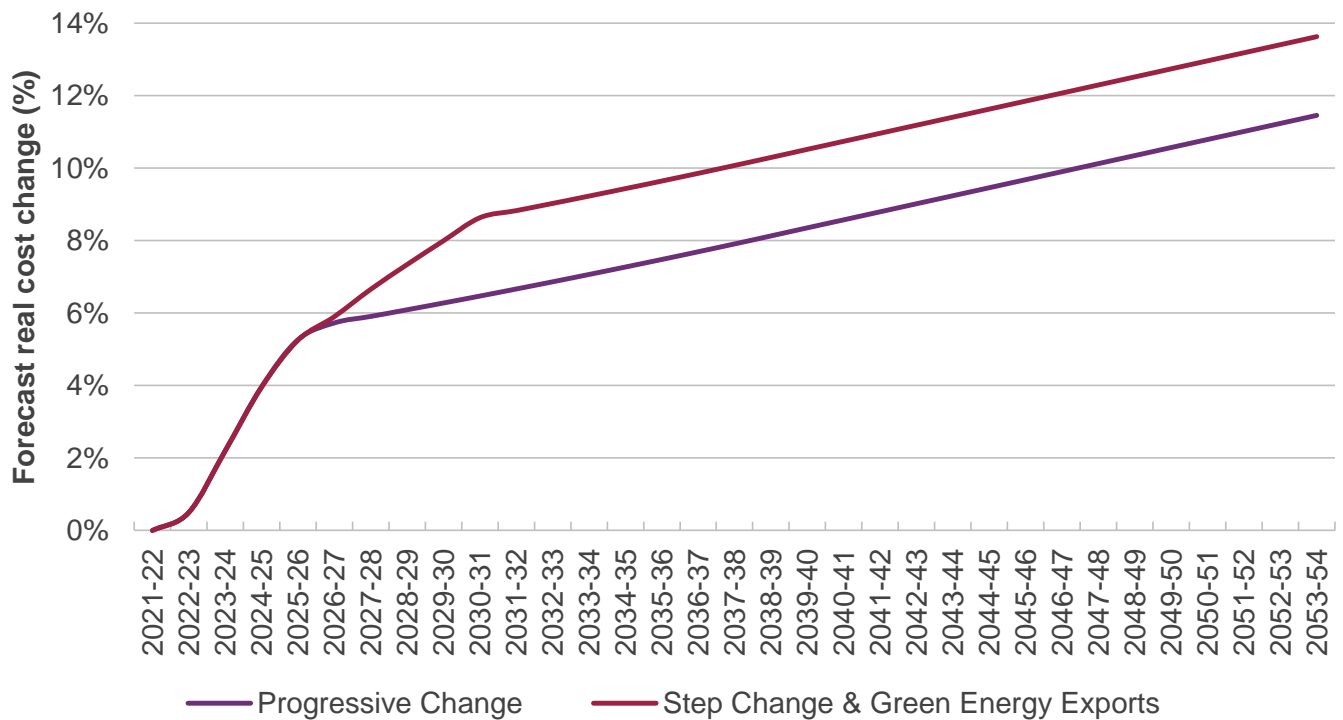

Figure 16 provides an indication of the different treatment for cost trajectories for transmission in the ISP. Costs are forecast to increase more under *Step Change* and *Green Energy Exports* scenarios, and to take longer to reach a 'new normal' than under *Progressive Change*. By 2039-40, costs are forecast to increase by around 11% in real terms under *Step Change* and *Green Energy Exports*, and about 8% for *Progressive Change*.

Figure 16 Indicative trends for the transmission forecasting approaches for the ISP (real \$2023)



2.8.2 Application of transmission cost forecasting in the ISP

AEMO will apply transmission cost forecasts to transmission augmentation projects which are actionable ISP projects, future ISP projects, and other augmentation options:

- For cost estimates produced by TNSPs and jurisdictional bodies – AEMO will only apply the transmission cost forecasts beyond the earliest in-service date (EISD) for the project. This is because TNSPs and jurisdictional bodies typically estimate the cost of a project for delivery at the EISD. An exception may apply if AEMO does not consider that the project proponent has provided an estimate for delivery date at the EISD.
- For cost estimates produced by AEMO in its National Transmission Planner function – AEMO will apply transmission cost forecasts from 2021-22. This is because AEMO National Transmission Planner's cost estimates reflect escalation indices from 2021-22 even though they are presented in 2022-23 dollars.

2.9 Transmission project lead time

The ISP ODP is strongly influenced by the lead times and earliest in-service dates (EISDs) assumed for transmission projects. These projects may already be committed or anticipated projects⁴⁸ from TNSPs and other organisations, or they may be more speculative options which are less certain or progressed.

AEMO has consulted on how the ISP framework can better incorporate the uncertainty associated with transmission project lead time through an update to the ISP Methodology⁴⁹. AEMO has now introduced the ability for EISDs to be revised by AEMO if needed. AEMO has a strong preference to only adjust EISDs through close joint planning and collaboration with the relevant TNSPs and/or jurisdictional bodies. However, AEMO considers it prudent to reserve the ability to apply adjustments to lead times based on transparent stakeholder feedback, and where there is sufficient evidence to support the adjustment⁵⁰.

AEMO has collaborated with TNSPs and jurisdictional bodies to understand project lead times for the augmentation options presented in the 2023 *Transmission Expansion Options Report*. AEMO has not adjusted any project lead times beyond what has been advised by TNSPs and jurisdictional bodies.

In the 2023 *Transmission Expansion Options Report*, AEMO has also re-defined the project lead time categories. A short lead time is now within 3-5 years (rather than 1-3 years for previous publications), a medium lead time is now within 6-7 years (rather than 4-5 for previous publications), and a long lead time is now beyond seven years (rather than five years and beyond for previous publications). This change has been made to acknowledge that regulatory and environmental approvals, as well as supply chain issues, mean that delivery of a new transmission project less than three years after the release of an ISP is highly unlikely.

⁴⁸ Committed transmission augmentation projects meet five criteria relating to planning consents, construction commencement, land acquisition, contracts for supply and construction of equipment, and necessary financing arrangements. Anticipated projects are in the process of meeting at least three of the criteria. Details about the criteria are provided in AEMO's Transmission Augmentation Information publication, at <https://aemo.com.au/energy-systems/electricity/national-electricity-market-nem/nem-forecasting-and-planning/forecasting-and-planning-data/transmission-augmentation-information>.

⁴⁹ AEMO's consultation page for the 2023 updates to the ISP Methodology is at <https://aemo.com.au/consultations/current-and-closed-consultations/consultation-on-updates-to-the-isp-methodology>.

⁵⁰ The update to the ISP Methodology also included an amendment to apply an actionable window concept. This change reflects the need to repeat regulatory approvals and other work if the actionable project status is removed and subsequently restored. This only impacts projects that were actionable in the previous ISP, and is mentioned here for completeness but will not affect project lead times noted in the 2023 *Transmission Expansion Options Report*. Further information about these updates is outlined in the ISP Methodology consultation materials, particularly AEMO's *Consultation summary report – Update to the ISP Methodology*, at https://aemo.com.au/-/media/files/stakeholder_consultation/consultations/nem-consultations/2023/isp-methodology-2023/consultation-summary-report---update-to-the-isp-methodology.pdf?la=en.

2.10 Social licence for transmission projects

‘Social licence’ is a term commonly used to refer to local community acceptance of new infrastructure development. The efficient and effective transition of the energy sector will rely on both government and the energy industry understanding and delivering the community's ambition and needs for the future power system, both broadly in the community, and in the places that host new development. Conversely, a lack of social licence could lead to significant project delays and increased cost.

AEMO has established an Advisory Council on Social Licence to assist in understanding social licence issues facing the energy transition for consideration in development of the ISP⁵¹.

AEMO has sought to incorporate social licence considerations in successive IASRs and ISPs through extensive consultation with governments, TNSPs, consumer advocates and other stakeholders⁵².

TNSPs and jurisdictional bodies also incorporate social licence considerations in their project design and cost estimates for projects which are under development. In cases where TNSPs' and jurisdictional bodies' cost estimates include allowances to address social licence matters, these will be in AEMO's cost estimates for the 2024 ISP where consistent with the processes outlined in Section 2.3 of this report.

AEMO expects that consideration of social licence matters for the NEM will continue through expansion of the already strong collaboration between generation developers, TNSPs, and NEM jurisdictional bodies. This includes ensuring the design of transmission assets take advantage of available design and technology choices to minimise their impact on land use.

In this report, AEMO provides conceptual options for a range of transmission augmentation projects. AEMO collaborates with TNSPs and jurisdictional bodies to co-design conceptual network options for the ISP. Where potential routes and locations are shown for projects, these are highly indicative only and should not be considered as fixed locations or routes.

AEMO is not responsible in its National Transmission Planner function for ultimate design, location or route selection or delivery of transmission projects in the NEM⁵³. As any projects become more likely or certain, the relevant TNSP or jurisdictional body will consider any potential routes and locations in detail as well as engage with potentially affected communities, landowners and other stakeholders.

AEMO considers that one of the best options for considering social licence implications through the ISP process is the use of sensitivity analysis to test the resilience of candidate development pathways to social licence limitations. This in turn informs selection of the ODP. The 2024 ISP will include at least sensitivities considering the impact of social licence matters. These sensitivities will explore the impact of higher transmission and generation projects costs, delays to transmission projects, or amended land use assumptions, to understand the impact of social licence on the ISP outcomes.

⁵¹ Further information about the Advisory Council on Social Licence is available at <https://aemo.com.au/consultations/industry-forums-and-working-groups/list-of-industry-forums-and-working-groups/social-licence-advisory-council>.

⁵² For the most recent IASR consultation, see the Draft 2023 IASR (pages 25, 118, 121 and 122), at <https://aemo.com.au/consultations/current-and-closed-consultations/2023-inputs-assumptions-and-scenarios-consultation>. For the most recent ISP, see <https://aemo.com.au/en/energy-systems/major-publications/integrated-system-plan-isp/2022-integrated-system-plan-isp>. Social licence is considered throughout the 2022 ISP, including a dedicated section in Appendix 3: Renewable Energy Zones.

⁵³ This statement applies to the ISP matters considered in this report as part of AEMO's role as the National Transmission Planner under the National Electricity Law. Separately, AEMO also has a unique role in Victoria, with responsibility for the planning of the Victorian transmission network. Further information about AEMO's role in Victoria is at <https://aemo.com.au/en/energy-systems/electricity/national-electricity-market-nem/nem-forecasting-and-planning/victorian-planning>.



Overall consideration of social licence matters in the 2024 ISP will be through:

- Selection of forecasting and planning scenarios, including trends relevant for social licence such as economic conditions in Australia and the pace of investment to decarbonise the economy,
- Selection of sensitivity analyses to consider the impact of variables relating to social licence on the ISP outcomes and to help inform selection of the ODP,
- Use of land use limits and resource limits in the ISP modelling, as consulted on through the IASR process,
- Selection of transmission augmentation options through collaboration and joint planning with TNSPs, jurisdictional bodies and other stakeholders,
- Inclusion of transmission project lead times in the modelling to incorporate time for community engagement⁵⁴,
- Selection of locations for potential REZs through consultation on successive IASRs and ISPs,
- Consideration of the input and feedback from external stakeholders, including the Advisory Council on Social Licence and the ISP Consumer Panel, and
- Potential application of any other appropriate methods to help inform selection of the ODP.

⁵⁴ This matter is also under consideration through consultation on updates to the ISP Methodology, at <https://aemo.com.au/consultations/current-and-closed-consultations/consultation-on-updates-to-the-isp-methodology>.

3 Flow paths

Flow paths are a feature of power system networks, representing the main transmission pathways over which bulk energy is shipped. They are the portion of the transmission network used to transport significant amounts of electricity across the backbone of the network to load centres. Flow paths change as new interconnection is developed, or as a result of shifting large amounts of generation into new areas (such as in the case of major REZ development).

This section outlines network augmentation options to increase the transfer capability of flow paths in the ISP. The following information is presented for each augmentation option:

- A description of the option.
- The expected increase in transfer capacity.
- The project cost, including the class of the estimate and associated accuracy.
- The project lead time.
- An overview of characteristics which are key cost drivers.

Many of the augmentation options included in this section are either undergoing a RIT-T or other regulatory process, or have preparatory activities being developed. Where available, transfer limits and cost estimates of these augmentation options were sourced from the relevant TNSPs and jurisdictional bodies.

Section 3 provides the following information:

- A legend and explanation of tables (Section 3.1).
- Central Queensland to North Queensland (Section 3.2).
- Central Queensland to Gladstone Grid (Section 3.3).
- Southern Queensland to Central Queensland (Section 3.4).
- Northern New South Wales to Southern Queensland (Section 3.5).
- Central New South Wales to Northern New South Wales (Section 3.6).
- Central New South Wales to Sydney, Newcastle and Wollongong (Section 3.7).
- Southern New South Wales to Central New South Wales (Section 3.8).
- Victoria to Southern New South Wales (Section 3.9).
- Tasmania to Victoria (Section 3.10).
- Victoria to South East South Australia (Section 3.11).
- South East South Australia to Central South Australia (Section 3.12).

Figure 17 Conceptual map of flow path options for 2023 Transmission Expansion Options Report

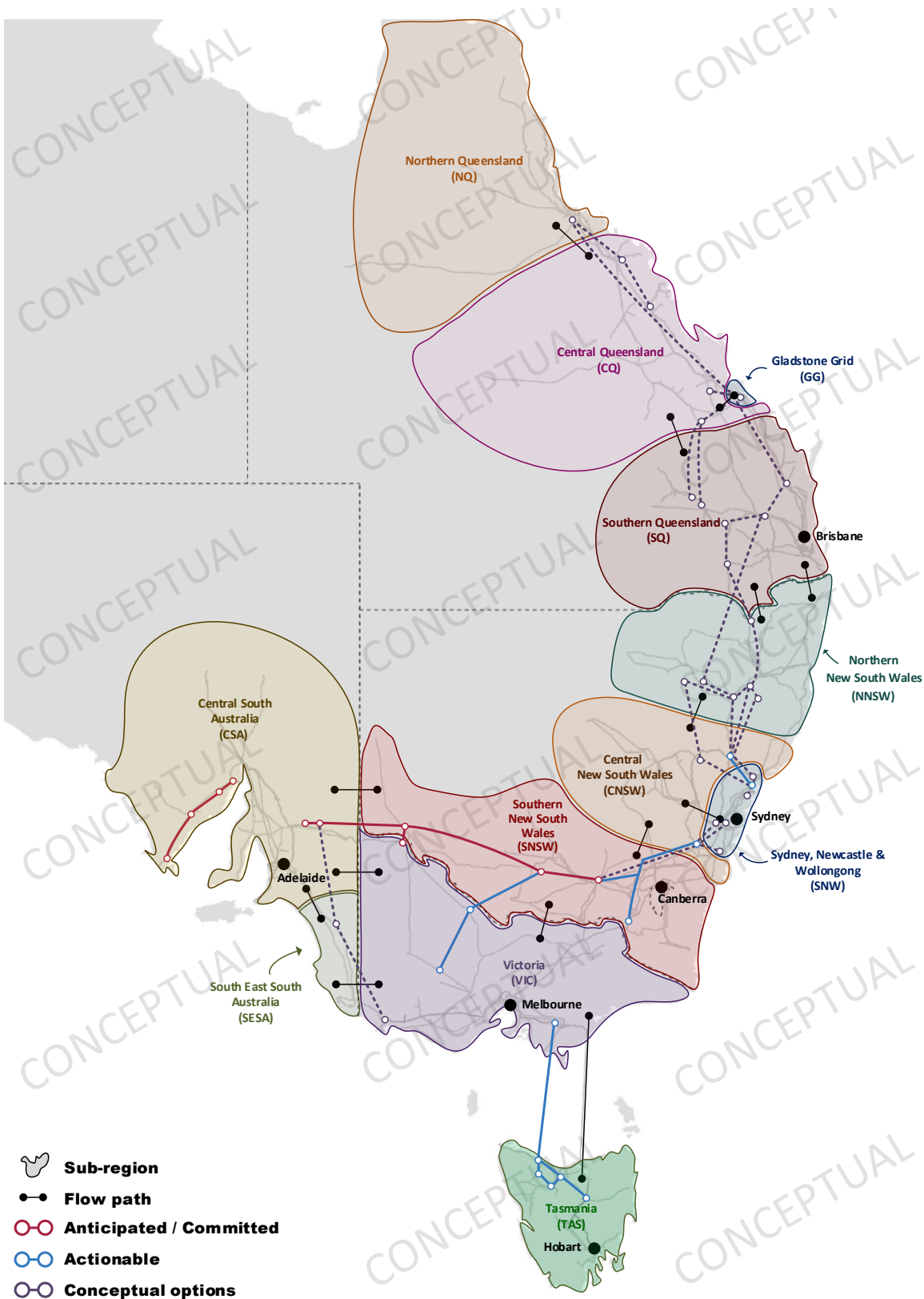

3.1 Legend and explanation of tables

The tables in Section 3 and Section 4 provide an overview of the characteristics of each network development option. The following template explains the criteria and terminology used in the tables.

Summary	
A brief description of the existing network is provided (for example, network capacity, projects to increase capacity, findings from the 2022 ISP).	
Existing network capability	
<p>For flow paths, this is the approximate maximum forward and reverse flow capability between the regions or sub-regions. These capabilities are represented by nominal transfer capacity when there are no transmission network outages in the local area. The capacity is sourced from recent historical data.</p> <p>For REZs, this is the capacity of the specific area of the network to allow connection of variable renewable energy (VRE) prior to curtailment being anticipated.</p> <p>The limit is the notional maximum transfer limit at the time of "Summer 10% probability of exceedance (POE) demand" (referred to as 'peak demand'), "Summer Typical", and "Winter Reference" in the importing region or sub-region, as outlined in the ISP Methodology. The figure quoted is the minimum of the following required limits: transmission asset thermal capacity; voltage stability; transient stability; oscillatory stability; and system strength and inertia.</p>	
Augmentation options – these include the conceptual design, capability, cost and timing for flow path augmentation options	
Additional network capacity (MW)	This is the additional network transfer capacity for each of the identified options and based on power system studies undertaken by AEMO or TNSPs. For flow paths the direction of power flow is stated. For REZs, the power flow is always in one direction from the REZ to the network.
Cost	<p>The costs are based on 2022 figures in (\$ million) but have been presented in real 2023 dollars. All cost estimates are indicative and prepared using AEMO's Transmission Cost Database, except for projects currently progressing through the RIT-T (or another regulatory process) or where preparatory activities were required in the 2022 ISP. Cost estimates for projects which are currently progressing through the RIT-T (or another regulatory process), or where preparatory activities were required in the 2022 ISP, are sourced from the relevant TNSP or NEM jurisdictional body.</p> <p>Costs shown in this report are rounded to two significant figures for readability. Non-rounded costs from the Transmission Cost Database, TNSPs or jurisdictional bodies will be used in the ISP modelling, and will be documented in the 2023 IASR Workbook.</p>
Cost classification	This is based on either AEMO's Transmission Cost Database or TNSPs' cost estimates information based on the AACE Cost Estimate Classification System as referenced in Section 2.1.
Lead time	Lead times represent the likely minimum time for service from the date of publication of the final 2024 ISP. The lead time includes regulatory justification and approval, relevant community engagement and planning approvals, procurement, construction, commissioning, and inter-network testing. Lead times are categorised as short (3-5 years), medium (6-7 years), or long (beyond 7 years).
Adjustment factors and risk – notes the adjustment factors, known risks and unknown risks applied to the option, for those estimates which were developed with the Transmission Cost Database.	
<p>Adjustment factors:</p> <ul style="list-style-type: none"> • Location (urban, regional and remote). • Greenfield/brownfield (greenfield, brownfield and partly brownfield) – greenfield is chosen unless otherwise specified. • Land use (desert, scrub, grazing and developed area). • Terrain (flat/farmland, mountainous and hilly/undulating). • Jurisdiction (state and Rural Bank defined sub-region⁵⁵). • Project network element size (transmission line length, project size). • Delivery timeframe (optimum, tight, long). • Contract delivery model (EPC contract, D&C contract) – EPC contract is chosen unless otherwise specified. • Proportion of environmentally sensitive areas (None, 25%, 50%, 75% and 100%). • Location wind loading zones (cyclone and non-cyclone regions) – non-cyclone region is chosen unless otherwise specified. 	

⁵⁵ Rural Bank. Australian Farmland Values. 2022. At <https://www.ruralbank.com.au/siteassets/documents/publications/flv/afv-national-2022.pdf>.



Known risk: where the risks are identified but ultimate value is not known. There are nine known risk factors:

- Compulsory acquisition (business as usual [BAU], low and high).
- Cultural heritage (BAU, low and high).
- Environmental offset risks (BAU, low, high, very high, and observed maximum).
- Geotechnical findings (BAU, low and high).
- Macroeconomic influence (BAU, increased uncertainty and heightened uncertainty).
- Market activity (BAU, tight and excess capacity).
- Outage restrictions (BAU, low and high).
- Project complexity (BAU, partly complex and highly complex).
- Weather delays (BAU, low and high).

Unknown risk: where the risk has not been identified but industry experience indicates these could occur:

- Scope and technology (Class 5b, Class 5a and Class 4).
- Productivity and labour cost (Class 5b, Class 5a and Class 4).
- Plant procurement cost (Class 5b, Class 5a and Class 4).
- Project overhead (Class 5b, Class 5a and Class 4).

3.2 Central Queensland to North Queensland

Summary				
<p>To improve the modelling of network losses, the Central-Northern sub-region from the 2022 ISP was further divided into North Queensland (NQ) and Central Queensland (CQ) sub-regions. Upgrade options associated with this new flow path may be built when generation in REZs Q1 to Q5 (Northern Queensland) exceeds 2,500 MW. These augmentations facilitate transmission of generation in northern Queensland to load centres further south.</p> <p>In previous ISPs, only a single option was proposed to increase the maximum network transfer capability between CQ and NQ. However, an additional option is now suggested which would permit the connection of a proposed Pioneer-Burdekin pumped hydro storage project (of up to 5,000 MW capacity) in North Queensland consistent with the Queensland Government’s announcement for the SuperGrid under the Queensland Energy and Jobs Plan (QEJP).</p>				
Existing network capability				
<p>The current network was designed to facilitate the transmission of power from Central Queensland to support the load in Northern Queensland. As a result, the Central and North Queensland sub-regions can only support up to 2,500 MW of generation across the five REZs in Northern Queensland, depending on the level of storage in the sub-region.</p> <p>From CQ to NQ maximum transfer capability is 1,200 MW at peak demand, summer typical levels and 1,400 MW at winter reference periods. The maximum transfer capability is limited by thermal ratings and voltage stability for the loss of CQ or NQ transmission network elements.</p> <p>From NQ to CQ maximum transfer capability is 1,200 MW at peak demand and summer typical levels and 1,400 MW at winter reference periods, assuming Powerlink upgrades limiting 8km of line into Ross from Strathmore 275kV.</p>				
Augmentation options				
Description	Additional network capacity (MW)	Expected cost(\$ million)	New easement length (km)	Lead time
<p>Option 1:</p> <ul style="list-style-type: none"> Construct an additional 275 kV double-circuit line from Ross to Strathmore to Nebo, initially switching one side only. 	1,100 (both directions of CQ to NQ) REZ Q3: 1,100	1,239 Class 5b (±50%)	350	Medium
<p>Option 2:</p> <ul style="list-style-type: none"> Establish 500 kV substations at locality of northern part of CQ. Substation works at Townsville 500kV (established as part of CopperString 2032 project) 2 x 1,500 MVA 500 / 275 kV transformers at northern CQ substation Establish a 500 kV double-circuit steel tower (DCST) line from CQ to northern CQ substations. Establish a 500 kV DCST line from northern CQ to NQ substations. Special protection scheme for transfer limit increase (similar to Virtual transmission line). Cost of this Network Service Agreement (NSA) excluded. <p><i>Prerequisite: CQ-SQ Option 5 (QEJP)</i></p>	3,000 (both directions of CQ to NQ) REZ Q3: 3,000 REZ Q2: 800	4,184 Class 5b (±50%)	750	Long
Adjustment factors and risk				



Option	Adjustment factors applied	Known and unknown risks applied
Option 1	<ul style="list-style-type: none"> • Land Use: Scrub • Jurisdiction: QLD - North • Project network element size: # of total Bays 1 - 5 / Above 200 km • Location (regional/distance factors): Regional • Delivery timetable: Long 	<p>Known Risks:</p> <ul style="list-style-type: none"> • Cultural heritage: BAU / Low • Geotechnical findings: BAU / Low • Market Activity: Tight • Others: BAU <p>Unknown risks: Class 5b</p>
Option 2	<p>As per Option 1</p> <ul style="list-style-type: none"> • Project network element size: Above 200km, 6-10 bays 	<p>As per Option 1 except:</p> <ul style="list-style-type: none"> • Market activity: BAU • Compulsory acquisition: Low

3.3 Central Queensland to Gladstone Grid

Summary				
<p>Following the retirement or reduced generation from Gladstone Power Station and increased generation in North Queensland, the transmission network supplying the Gladstone area will be constrained. This will restrict supply to forecast demand at Boyne Island, Calliope River, Larcom Creek and Raglan substations. If major industrial loads are electrified, or if large Hydrogen projects progress, there is a potential for a material shift in the supply-demand balance in the Gladstone area.</p> <p>In the 2020 ISP, AEMO required Powerlink to complete preparatory activities for reinforcement of Central and North Queensland (CNQ) and Gladstone Grid (GG).</p>				
Existing network capability				
<p>The maximum supportable load is influenced by the amount of generation dispatched within northern and central Queensland, particularly at Gladstone. The transfer capability is influenced by the thermal capacity of the Calvale–Wurdong, Bouldercombe–Calliope River, Bouldercombe–Raglan, Larcom Creek–Calliope River or Calliope River–Wurdong 275 kV circuits.</p> <ul style="list-style-type: none"> With typical generation output from Gladstone, CQ to GG maximum transfer capability is 700 MW at peak demand and summer typical levels, and 1,050 MW at winter reference conditions. In the reverse direction, GG to CQ maximum transfer capability is 750 MW at peak demand and summer typical levels and approximately 1,100 MW at winter reference periods. 				
Augmentation options				
Description	Additional network capacity (MW)	Expected cost (\$ million)	New easement length (km)	Lead time
<p>Option 1:</p> <ul style="list-style-type: none"> New 275 kV high-capacity double-circuit line between Calvale and Calliope River. Rebuild Calliope River to Larcom Creek 275 kV high-capacity double-circuit line. Rebuild Larcom Creek to Bouldercombe 275 kV high-capacity double-circuit line with one line switched at Raglan. A new (third) 275/132 kV transformer at Calliope River. <p><i>Provided by Powerlink – see Section 1.2.</i></p>	<p>2,600 (CQ to GG) 500 (GG to CQ)</p>	<p>1,300 Class 5b (±50%)</p>	<p>90⁵⁶</p>	<p>Short</p>
Adjustment factors and risk: N/A (Preparatory activity)				

⁵⁶ AEMO will clarify with Powerlink whether new circuit will be on an existing easement, and will adjust the modelling application of land owner payment schemes as necessary.

3.4 Southern Queensland to Central Queensland

Summary				
<p>The maximum transfer capability from Central Queensland (CQ) to Southern Queensland (SQ) is currently limited to approximately 2,100 MW. As new generation connects in CQ and NQ, congestion along this corridor will increase and generation will be curtailed.</p> <p>In previous ISPs, four options were proposed to increase the maximum network transfer capability between CQ and SQ. However, with the QEJP, a new Option 5 is added.</p>				
Existing network capability				
<p>From CQ to SQ maximum transfer capability is approximately 2,100 MW. This capability is applicable in peak demand, summer typical, and winter reference periods.</p> <p>The maximum power transfer from CQ to SQ grid section is limited by transient or voltage stability following a Calvale to Halys 275 kV circuit contingency.</p> <p>From SQ to CQ maximum transfer capability is 1,100 MW at peak demand, summer typical levels and at winter reference periods. This assumes Powerlink establishes a new double circuit line from Blackwall to Karana Downs allowing dedicated double circuit connections from Blackwall to Rocklea and Blackwall to South Pine. Following these works the maximum transfer capability from SQ to CQ is limited by thermal capacity of the Palmwoods – South Pine 275 kV line following a credible contingency.</p>				
Augmentation options				
Description	Additional network capacity (MW)	Expected cost (\$ million)	New easement length (km)	Lead time
<p>Option 1:</p> <ul style="list-style-type: none"> A new 275 kV double-circuit line between Calvale and Wandoan South. 275 kV line shunt reactors at both ends of Calvale – Wandoan South 275 kV circuits. 	900 (both directions of SQ to CQ). REZ Q6: 900	894 Class 5b (±50%)	275	Medium
<p>Option 2:</p> <ul style="list-style-type: none"> Mid-point switching substation on the existing Calvale–Halys 275 kV double-circuit line. 	0 (SQ to CQ) 300 (CQ to SQ)	77 Class 5b (±50%)	0	Short
<p>Option 3:</p> <ul style="list-style-type: none"> Non-network option – a Virtual Transmission Line option with a 300 MW energy storage system north of Calvale and south of Halys. 	300 (both directions of SQ to CQ)	Non-network augmentation	0	N/A
<p>Option 4:</p> <ul style="list-style-type: none"> A 1,500 MW HVDC bi-pole overhead transmission line from Calvale to South West Queensland. A new 1,500 MW HVDC bipole converter station in locality of Calvale. A new 1,500 MW HVDC bipole converter station in South West Queensland. AC network connection between HVDC converter station and 275 kV substation in Calvale. AC network connection between HVDC converter station and 275 kV AC network in South West Queensland. 	1,500 (both directions of SQ to CQ) REZ Q6: 1,500	1,853 Class 5b (±50%)	250	Long
<p>Option 5:</p> <ul style="list-style-type: none"> Establish 500 kV Halys substation (with 3 x 500/275 kV 1,500 MVA transformers). 	3,150 (both directions of SQ to CQ) Q1-Q6 path: 3,000 (should	3,287 Class 5b (±50%)	492	Medium

<ul style="list-style-type: none"> Establish 500 kV substations west of Gladstone (CQ 500 kV substation) and Woolooga West (each with 2x500/275 kV 1,500 MVA transformers). Establish CQ 275 kV substation. Install dynamic reactive support at CQ substation. Establish a 500 kV double-circuit line between Halys and Woolooga West substations. Establish a 500 kV double-circuit line between Woolooga West to CQ substations. Establish a 275 kV double-circuit line from Woolooga West to existing Woolooga Substation. Cut the Calliope River to Calvale circuits into the CQ 275 kV substation. Establish a 275 kV DCST line from CQ 275 kV substation to Larcom Creek Install 2x 275 kV power flow control at existing Woolooga substation on existing 275 kV eastern corridor to South Pine Special protection scheme for transfer limit increase (similar to Virtual transmission line). Cost of this NSA excluded. <p><i>Prerequisite: CNQ-GG Option 1 (GGR)</i></p>	<p>there be no transmission constraints further north)</p>			
Adjustment factors and risk				
Option	Adjustment factors applied	Known and unknown risks applied		
Option 1	<ul style="list-style-type: none"> Land Use: Scrub Jurisdiction: QLD – South Project network element size: # of total Bays 1 – 5 Location (regional/distance factors): Regional 	<p>Known Risks:</p> <ul style="list-style-type: none"> Outage restrictions : High Others: BAU <p>Unknown risks: Class 5b</p>		
Option 2	<ul style="list-style-type: none"> Land Use: Scrub Jurisdiction: QLD – South Project network element size: # of total Bays 1 – 5 Location (regional/distance factors): Regional Delivery timetable: Optimum 	<p>Known Risks:</p> <ul style="list-style-type: none"> Outage restrictions : High Market activity: Tight Others: BAU <p>Unknown risks: Class 5b</p>		
Option 3	NSA not costed	NSA not costed		
Option 4	<ul style="list-style-type: none"> Land Use: Grazing Jurisdiction: QLD – South/QLD – Central Project network element size: # of total Bays above 31/applicable for HVDC converter station project/Above 200 km Location (regional/distance factors): Remote/Regional Delivery timetable: Long 	<p>Known Risks:</p> <ul style="list-style-type: none"> Project complexity : Highly complex/BAU Others: BAU <p>Unknown risks: Class 5b</p>		
Option 5	<ul style="list-style-type: none"> Land Use: Grazing/Scrub Jurisdiction: QLD – South/QLD – Central Project network element size: # of total Bays 16 – 20/Above 200 km Location (regional/distance factors): Regional Delivery timetable: Tight/Optimum 	<p>Known Risks:</p> <ul style="list-style-type: none"> Outage restrictions : High/BAU Project complexity : BAU/Partly complex Market activity : Tight Others: BAU <p>Unknown risks: Class 5b</p>		

3.5 Northern New South Wales to Southern Queensland

Summary				
<p>The Northern New South Wales (NNSW) and Southern Queensland (SQ) corridor represents a portion of the network which forms part of the Queensland – New South Wales Interconnector (QNI).</p> <p>The QNI Minor project which increases the transfer capacity of the existing QNI has been commissioned and inter-network testing considered complete from summer 2023-24.</p> <p>An additional new interconnection between Queensland and New South Wales (QNI Connect) would increase transfer capacity between Queensland and New South Wales to share renewable energy and firming services between regions. In the 2022 ISP, AEMO required that Powerlink and Transgrid complete preparatory activities for QNI Connect 500 kV option, and that Transgrid complete preparatory activities for a QNI Connect 330 kV Option.</p>				
Existing network capability				
<p>NNSW to SQ expected transfer capability is 685 MW at peak demand and 745 MW at summer typical and winter reference periods. The maximum transfer capability is limited by voltage or transient stability for loss of the Kogan Creek generator.</p> <p>In the reverse direction, SQ to NNSW expected transfer capability is 1,205 MW, 1,165 MW and 1,170 MW at peak, summer typical and winter reference periods respectively. The transfer capability is limited by thermal capacity of 330 kV lines between Bulli Creek and Armidale or Armidale and Tamworth following a credible contingency.</p>				
Augmentation options				
Description	Additional network capacity (MW)	Expected cost (\$ million)	New easement length (km)	Lead time
<p>Option 1:</p> <ul style="list-style-type: none"> A new 330 kV single-circuit line from locality of New England Hub 5 to Dumaresq to Bulli Creek to Braemar. A new 330/275 kV transformer at Braemar. 330 kV Line shunt reactor at New England Hub 5, Dumaresq, Bulli Creek, and Braemar for the New England Hub 5 – Dumaresq – Bulli Creek – Braemar 330 kV circuits. <p>(Pre-requisite: Cut-in both Tamworth-Armidale 330 kV lines to a new substation in locality of New England Hub 5). Provided by Powerlink and Transgrid – see Section 1.2.</p>	730 (NNSW to SQ) 900 (SQ to NNSW)	1,893 ⁵⁷ Class 5 (±50%)	461	Medium
<p>Option 2:</p> <ul style="list-style-type: none"> A new 330 kV double-circuit line from locality of New England Hub 5 to Dumaresq to Bulli Creek to Braemar. New 330/275 kV transformers at Braemar. 330 kV Line shunt reactors at New England Hub 5, Dumaresq, Bulli Creek, and Braemar, for the 330 kV lines between New England Hub 5 and Braemar (via Dumaresq and Bulli Creek). (Pre-requisite: Cut-in both Tamworth–Armidale 330 kV lines to a new substation in locality of New England Hub 5). <p>Provided by Powerlink and Transgrid – see Section 1.2.</p>	1,260 (NNSW to SQ) 1,700 (SQ to NNSW)	2,518 ⁵⁴ Class 5 (±50%)	461	Medium
<p>Option 3:</p> <ul style="list-style-type: none"> A Virtual Transmission Line option with a 200 MW energy storage system south of Armidale and north of Braemar. 	200 (in both directions of NNSW to SQ)	Non-network augmentation	0	N/A

⁵⁷ Please see Preparatory Activities page, available at: <https://aemo.com.au/consultations/current-and-closed-consultations/2023-transmission-expansion-options-report-consultation>

<p>Option 4:</p> <ul style="list-style-type: none"> • A 2,000 MW HVDC bi-pole overhead transmission between a new substation in North West New South Wales (NWNSW) REZ and Halys. • A new 2,000 HVDC bipole converter station in North West New South Wales. • A new 2,000 HVDC bipole converter station in locality of Halys. • AC network connection between HVDC converter station and 275 kV substation in Halys. • AC network connection between HVDC converter station and ac network in in NWNSW REZ. • A new 330 kV line between NWNSW REZ and Tamworth. 	<p>1,800 (NNSW to SQ) 2,000 (SQ to NNSW)</p>	<p>4,279 Class 5b (±50%)</p>	<p>765</p>	<p>Long</p>
<p>Option 5:</p> <ul style="list-style-type: none"> • Establish a new substation in NNSW and to New England REZ Hub 5. • A new 500/275 kV transformer at Halys substation. • A new 1x500 kV double-circuit line between Halys and new Dumaresq 500 kV substation in NNSW. • A new 1x500 kV double-circuit line between Dumaresq and New England REZ Hub 5. • 2x 500/330 kV transformers connecting to 330 kV Dumaresq. <p><i>Pre-requisite: CQ-SQ Option 5 (QEJP), CNSW-NNSW Option 1. Provided by Powerlink and Transgrid – see Section 1.2.</i></p>	<p>3,000 (NNSW to SQ) 2,500 (SQ to NNSW)</p>	<p>5,260⁵⁸ Class 5 (±50%)</p>	<p>616</p>	<p>Long</p>

Adjustment factors and risk		
Option	Adjustment factors applied	Known and unknown risks applied
Option 1	Preparatory Activity	Preparatory Activity
Option 2	Preparatory Activity	Preparatory Activity
Option 4	<ul style="list-style-type: none"> • Land Use: Grazing • Jurisdiction: QLD – South/NSW – Northern • Project network element size: # of total Bays above 31/applicable for HVDC converter station project/Above 200 km • Location (regional/distance factors): Remote • Delivery timetable: Long/Optimum 	<p>Known Risks:</p> <ul style="list-style-type: none"> • Project complexity: Highly complex • Others: BAU <p>Unknown risks: Class 5b</p>
Option 5	Preparatory Activity	Preparatory Activity

⁵⁸ Please see Preparatory Activities page, at: <https://aemo.com.au/consultations/current-and-closed-consultations/2023-transmission-expansion-options-report-consultation>.

3.6 Central New South Wales to Northern New South Wales

Summary				
<p>The Central New South Wales (CNSW) to Northern New South Wales (NNSW) corridor represents a portion of the network which forms part of QNI. Development options on this corridor include access of increased renewable generation and energy storage in New England REZ to supply the major load centres in New South Wales as well as the southern sections of proposed QNI upgrades.</p> <p>The QNI Minor project which increases the transfer capacity of the existing QNI has been commissioned and considered in service from June 2023. This means it's included in the capacity calculations below. In the 2022 ISP, AEMO recommended that Powerlink and Transgrid complete preparatory activities for QNI Connect 500 kV option and additionally Transgrid to complete NSW scope of QNI Connect 330 kV Option.</p> <p>In the 2022 ISP, major augmentation of CNSW-NNSW flow path was identified as an actionable New South Wales project (New England REZ Transmission Link) as defined in the New South Wales Electricity Strategy.</p>				
Existing network capability				
<ul style="list-style-type: none"> CNSW to NNSW maximum transfer capability is 910 MW at peak demand, summer typical and winter reference periods. The maximum transfer capability is limited by voltage stability for loss of Kogan Creek generator. NNSW to CNSW maximum transfer capability is 930 MW at peak demand and summer typical periods and 1,025 MW at winter reference period. The maximum transfer capability is limited by thermal capacity of Armidale–Tamworth 330 kV lines following a credible contingency. 				
Augmentation options				
Description	Additional network capacity (MW)	Expected cost (\$ million)	New easement length (km)	Lead time
<p>Option 1:</p> <ul style="list-style-type: none"> New Central South (Hub 1) 500/330 kV substation in New England with 3 x 500/330/33 kV 1,500 MVA transformers. New 330 kV Central (Hub5) switching station in New England and cut into the existing lines between Tamworth and Armidale. New 500 kV built and initially 330 kV operated double-circuit line from Hub 5 to Hub 1. New 500 kV double-circuit line between Hub 1 and Bayswater with Quad Orange conductor. 4 x 500 kV 150 MVA line shunt reactors (in total) are required for 500 kV double-circuit line between Hub 1 and Bayswater. New 6 x 330 kV 200 MVA power flow control at Hub 5. 	3,000 (both directions of CNSW to NNSW) REZ N2: 2,000	1,834 Class 5b (±50%)	225	Medium
<p>Option 2:</p> <ul style="list-style-type: none"> Expand Hub 5 switching station to 500/330 kV substation with 3 x 500/330/33 kV 1,500 MVA transformers. Operate line between Hub 5 and Hub 1 from 330 kV to 500 kV. New 500 kV double-circuit from Hub 5 to Bayswater with Quad Orange conductor. 4 x 500 kV 150 MVA line shunt reactors (in total) are required for 500 kV double-circuit line between Hub 5 and Bayswater. <p><i>Pre-requisite: CNSW-NNSW Option 1.</i></p>	3,000 (both directions of CNSW to NNSW) (assuming downstream limitations addressed by Hunter Transmission Project/CNSW-SNW Option 1). REZ N2: 3,000	1,493 Class 5b (±50%)	217	Long
Option 3:	3,600 (both directions of	2,452	225	Long

<ul style="list-style-type: none"> • New Central South (Hub 1) 500/330 kV substation in New England with 3 x 500/330/33 kV 1,500 MVA transformers. • New 330 kV Central (Hub5) switching station in New England and cut into the existing lines between Tamworth and Armidale. • New 500 kV built and initially 330 kV operated double-circuit line from Hub 5 to Hub 1 • New 500 kV double-circuit line between Hub 1 and Bayswater with Quad Orange conductor. • 4 x 500 kV 150 MVA line shunt reactors (in total) are required for 500 kV double-circuit line between Hub 1 and Bayswater. • Rebuild portion of Line 86 from Hub 5 to Tamworth as 330 kV double-circuit line. • Rebuild Line 88 Tamworth – Muswellbrook and Line 83 Liddell – Muswellbrook as 330 kV double-circuit line. • Augment Hub 5, Tamworth, Muswellbrook and Liddell to accommodate additional lines. 	CNSW to NNSW REZ N1+N2: 3,600	Class 5b (± 50%)		
<p>Option 4:</p> <ul style="list-style-type: none"> • 2,000 MW bi-pole HVDC transmission system between locality Bayswater and locality of Hub 5. • A new 330 kV double-circuit line from a new substation in locality of Hub 5 to Armidale. • Reconnect both Tamworth-Armidale 330 kV lines from Armidale to a new substation in locality of Hub 5. 	1,750 (CNSW to NNSW) 2,000 (NNSW to CNSW) REZ N2: 2,000 MW	2,544 Class 5b (± 50%)	280	Long
<p>Option 5:</p> <ul style="list-style-type: none"> • A 2,000 MW bi-pole HVDC transmission system between locality of Wollar and locality of Boggabri. • A new 330 kV AC line between locality of Boggabri and Tamworth. 	1,750 (CNSW to NNSW) 2,000 (NNSW to CNSW) REZ N1: 2,000 MW	2,796 Class 5b (± 50%)	350	Long

Adjustment factors and risk

Option	Adjustment factors applied	Known and unknown risks applied
Option 1	<ul style="list-style-type: none"> • Land Use: Grazing • Jurisdiction: NSW – Central/NSW – Northern • Project network element size: # of total Bays 16 – 20/Above 200 km • Location (regional/distance factors): Remote • Delivery timetable: Long 	<p>Known Risks:</p> <ul style="list-style-type: none"> • Environmental offset risks: High • Market activity: Tight • Others: BAU <p>Unknown risks: Class 5b</p>
Option 2	As per Option 1 above	As per Option 1 above, except: <ul style="list-style-type: none"> • Market activity: BAU
Option 3	As per Option 1 above	As per Option 2 above
Option 4	<ul style="list-style-type: none"> • Land Use: Grazing • Jurisdiction: NSW – Central/NSW – Northern • Project network element size: # of total Bays above 31/applicable for HVDC converter station project/Above 200 km • Location (regional/distance factors): Remote/Regional • Delivery timetable: Long 	<p>Known Risks:</p> <ul style="list-style-type: none"> • Compulsory acquisition: High/BAU • Outage restrictions: High/BAU • Project complexity: Highly complex • Environmental offset risks: High • Others: BAU <p>Unknown risks: Class 5b</p>
Option 5	As per Option 4 above	<p>Known Risks:</p> <ul style="list-style-type: none"> • Compulsory acquisition: High/BAU • Project complexity: Highly complex • Environmental offset risks: High • Others: BAU <p>Unknown risks: Class 5b</p>

3.7 Central New South Wales to Sydney, Newcastle and Wollongong

Summary				
<p>The transmission network in the Sydney, Newcastle, and Wollongong (SNW) area was originally designed to connect large coal-fired generators in the Hunter Valley to supply the SNW load centres. When these coal-fired generators retire, the network has insufficient capability to supply SNW load centres from generators located outside of the Hunter Valley. Additional transmission network augmentation may be needed to supply the load centre.</p> <p>The Waratah Super Battery (WSB) project is a priority transmission project in NSW⁵⁹. WSB with a System Integrity Protection Scheme (SIPS) is proposed to increase transfer capacity from CNSW to SNW. This project also includes minor network augmentation to increase thermal capacity of Bannaby–Sydney West, Yass–Marulan and Yass–Collector–Marulan 330 kV lines.</p> <p>In the 2022 ISP, the Sydney Ring (Reinforcing Sydney, Newcastle and Wollongong Supply) or the Hunter Transmission Project was identified as an actionable ISP Project.</p>				
Existing network capability				
<p>The existing transfer capability varies depending on load and generation distribution within Sydney, Newcastle, and Wollongong areas, as well as the generation pattern from northern and southern NSW sub-regions.</p> <p>For the existing network, transfer capability from the north and the south are separately identified to better define these limitations.</p> <p>CNSW-SNW North flow path: <i>(sum of CNSW-SNW flow paths less CNSW-SNW South flow paths, see below)</i></p> <p>The maximum transfer capability of the northern side of CNSW-SNW flow path is 4,490 MW at peak demand and summer typical, and 4,730 at winter reference periods.</p> <p>Maximum transfer capability is limited by several 330 kV lines and the most limiting elements are Liddell-Newcastle and Liddell-Tomago 330 kV lines.</p> <p>It is assumed Vales Point generation is at maximum output and Eraring generation at zero output in these transfer limit calculations. The CNSW-SNW North transfer capability will increase by 0.12 MW for 1 MW (12%) of increased Eraring generation.</p> <p>CNSW-SNW South flow path: <i>(sum of flows on Bannaby – Sydney West, Marulan – Dapto, Marulan – Avon and Kangaroo Valley – Dapto 330 kV lines)</i></p> <p>The maximum transfer capability from the southern side of CNSW-SNW flow path is 2,540 MW at peak demand and summer typical, and 2,720 at winter reference periods.</p> <p>Maximum transfer capability is limited by several 330 kV lines and the most limiting element is Bannaby-Sydney West 330 kV line.</p> <p>It is assumed Tallawarra generation is at zero output in these transfer limit calculations. CNSW-SNW South transfer capability will reduce by 0.51 MW for 1 MW (51%) of increased Tallawarra generation.</p> <p>The WSB project (including battery, SIPS, minor network augmentations, paired generation) is expected to increase the transfer capability by 660 MW and 250 MW for CNSW-SNW North and South, respectively.</p>				
Augmentation options				
Description	Additional network capacity (MW)	Expected cost (\$ million)	New easement length (km)	Lead time
<p>Option 1</p> <p>SNW Northern 500 kV loop or the Hunter Transmission Project (HTP):</p> <ul style="list-style-type: none"> Expand existing Eraring 500 kV substation. A new 500 kV double-circuit line between Eraring and Bayswater substation. Line reactors on 500 kV transmission lines between Eraring and Bayswater. Two new 500/330 kV 1,500 MVA transformers at Eraring substation. 	<p>5,000</p> <p>(This capacity increase is for accommodation of additional new generation from North of Bayswater and 2/3 generation)</p>	<p>926</p> <p>Class 5b (± 50%)</p>	105	Medium

⁵⁹ New South Wales Government, October 2022, "Government Gazette". At https://gazette.legislation.nsw.gov.au/so/download.w3p?id=Gazette_2022_2022-473.pdf.

	from Central-West NSW) REZ N10: 2,000			
Option 2 SNW Southern Loop: <ul style="list-style-type: none"> Establish a new substation in the locality of South Creek with 2 x 500/330/33 kV, 1,500 MVA transformers. Connect the new substation in the locality of South Creek into Eraring – Kemps Creek 500 kV lines and Bayswater – Sydney West and Regentville – Sydney West 330 kV lines. A new 500 kV double-circuit lines from Bannaby to the new substation in the locality of South Creek. Rebuild the section of existing Bannaby – Sydney West 330 kV line from locality of South Creek to Sydney West to double-circuit line. Augment the existing Bannaby and Sydney West substations. Line reactors on 500 kV transmission lines between Bannaby and locality of South Creek. <i>Provided by Transgrid – see Section 1.2.</i>	4,500 (This capacity increase is for accommodation of additional new generation south of Bannaby and 1/3 generation from Central-West NSW). REZ N11:2,000	1,550 (2023 dollars) ⁶⁰ Class 5 (-30% to +40%)	125	Medium
Option 2b: <ul style="list-style-type: none"> Rebuild line 39 from Bannaby to Sydney West as double-circuit line. Augment the existing Bannaby and Sydney West substations. 	1,200 CNSW-SNW (This capacity increase is for accommodation of additional new generation from south of Bannaby)	553 Class 5b (± 50%)	0	Medium
Option 3 Both SNW Northern 500 kV loop and SNW Southern 500 kV loop: <ul style="list-style-type: none"> CNSW-SNW Option 1. CNSW-SNW Option 2. 	8,600 ⁶¹ (This capacity increase of 8,600 MW consists of maximum generation of 5,000 MW from NNSW and 4,500 MW from SSNW)	2,038 Class 5b (± 50%)	230	Long
Option 4: <ul style="list-style-type: none"> A new 500 kV substation near Eraring. A new 500 kV double-circuit line between substation near Eraring and Eraring. A new 500 kV double-circuit line between Wollar South and new Eraring substation. Two 500/330 kV 1,500 MVA transformers at Kemps Creek. 1 x 330 kV single-circuit line between Vales Pt and new Eraring. 1 x 330 kV single-circuit line between Vales Pt and Munmorah. Thermal upgrade for Line 24 Vales Pt – Eraring and 92 Newcastle – Vales Point. 1 x 330 kV single-circuit line between Liddell – Newcastle. 1 x 330 kV single-circuit line between Eraring – Newcastle. Line reactors on 500 kV transmission lines. <i>Pre-requisite: CNSW-SNW Option 1, N3 REZ Option 1.</i>	4,400 REZ N10:2,000 (This capacity increase is for accommodation of additional new generation from Central-West NSW)	2,470 Class 5b (± 50%)	418	Long
H-Newcastle To provide access to port new Newcastle: <ul style="list-style-type: none"> Three new 500 kV lines from Bayswater to Newcastle. 	5,000 (This is not an alternative option to supply SNW)	1,663 Class 5b (± 50%)	210	Long

⁶⁰ This includes cost estimates for this option. AEMO has published Transgrid’s June 2023 report, ISP Preparatory Activities – Reinforcing Sydney, Newcastle and Wollongong Supply (Southern Circuit). This report is available via <https://aemo.com.au/consultations/current-and-closed-consultations/2023-transmission-expansion-options-report-consultation>.

⁶¹ Transfer limit for CNSW-SNW Option 3 in 2022 ISP was 5,600 MW. This has been revised with increased load in SNW. Consistent load assumptions applied for all 500 kV augmentation options following HTP. Applicable for options 3, 4, 6a and 6b.

<ul style="list-style-type: none"> Four new 500/330 kV transformers at Newcastle. Line shunt reactors at each of the new 500 kV lines. 	This augmentation allows expansion of REZ N10.			
<p>H-Dapto</p> <p>To provide access to port near Dapto:</p> <ul style="list-style-type: none"> Three new 500 kV lines from Bannaby to Dapto. Four new 500/330 kV transformers at Dapto. Line shunt reactors at each of the new 500 kV lines. 	5,000 (This is not an alternative option to supply SNW) This augmentation allows expansion of REZ N11.	1,420 Class 5b (± 50%)	194	Long
<p>CNSW-SNW Option 6a:</p> <ul style="list-style-type: none"> A new 500 kV substation near Eraring substation. A new 500 kV double-circuit line between substation near Eraring and Bayswater substation. Two 500/330 kV 1,500 MVA transformers either at Eraring substation or new substation near Eraring. Two 500/330 kV 1,500 MVA transformers at Kemps Creek. 1 x 330 kV SCST line between Vales Pt and Eraring. 1 x 330 kV SCST line between Vales Pt and Munmorah. Thermal upgrade for Line 24 Vales Pt – Eraring and 92 Newcastle – Vales Point. 1 x 330 kV SCST line between Liddell – Newcastle. 1 x 330 kV SCST line between Eraring – Newcastle. <p><i>Pre-requisite: CNSW-SNW Option 1.</i></p>	4,400 (This capacity increase is for accommodation of additional new generation from NNSW and CNSW)	1,833 Class 5b (± 50%)	263	Long
<p>CNSW-SNW Option 6b:</p> <ul style="list-style-type: none"> A new 500 kV substation near Eraring substation. A new 500 kV double-circuit line between substation near Eraring and Bayswater substation. A new 500/330 kV substation in locality of Richmond Vale with two 500/330 kV 1,500 MVA transformers cut in Line 81 and 82. Two 500/330 kV 1,500 MVA transformers at new substation near Eraring. 1 x 330 kV single-circuit line between Vales Pt and new Eraring. 1 x 330 kV single-circuit line between Vales Pt and Munmorah. Thermal upgrade for Line 24 Vales Pt – Eraring and 92 Newcastle – Vales Point. 1 x 330 kV single-circuit line between locality of Richmond Vale – Newcastle. Line reactors on 500 kV transmission lines. <p><i>Pre-requisite: CNSW-SNW Option 1.</i></p>	4,400 (This capacity increase is for accommodation of additional new generation from NNSW and CNSW)	1,411 Class 5b (± 50%)	156	Long

Adjustment factors and risk

Option	Adjustment factors applied	Known and unknown risks applied
Option 1	<ul style="list-style-type: none"> Land Use: Developed area Jurisdiction: NSW – Central Project network element size: # of total Bays 1 – 5/100 to 200 km Location (regional/distance factors): Regional Delivery timetable: Long 	<p>Known Risks:</p> <ul style="list-style-type: none"> Compulsory acquisition : High/BAU Outage restrictions : High Project complexity : BAU/Partly complex Environmental offset risks : High Market activity : Tight Others: BAU <p>Unknown risks: Class 5b</p>
Option 2	Preparatory Activity	Preparatory Activity
Option 2b	<p>As per Option 2 except:</p> <ul style="list-style-type: none"> Project network element size: 100 to 200 km/# of total Bays 6 – 10 Jurisdiction: NSW – Central 	<p>Known Risks:</p> <ul style="list-style-type: none"> Compulsory acquisition: High/BAU Outage restrictions: High/BAU

	<ul style="list-style-type: none"> Project network element size: 100 to 200km / # of total Bays 6 – 10 Land Use: Developed area / Scrub Location (regional/distance factors): Regional / Urban <p>Delivery timetable: Long</p>	<ul style="list-style-type: none"> Environmental offset risks: High Market activity: Tight Others: BAU <p>Unknown risks: Class 5b</p>
Option 3	<p>As per Option 2b except:</p> <ul style="list-style-type: none"> Project network element size: # of total Bays 16 – 20 / Above 200 km 	<p>Known Risks:</p> <ul style="list-style-type: none"> Compulsory acquisition : BAU/High Outage restrictions : BAU/High Project complexity : Partly complex Environmental offset risks : High Others: BAU <p>Unknown risks: Class 5b</p>
Option 4	<p>As per Option 2b except:</p> <ul style="list-style-type: none"> Land Use: Developed area 	<p>Known Risks:</p> <ul style="list-style-type: none"> Compulsory acquisition: High/BAU Outage restrictions: High Project complexity: Partly complex Environmental offset risks: High Others: BAU <p>Unknown risks: Class 5b</p>
H-Newcastle	<p>As per Option 2b except:</p> <ul style="list-style-type: none"> Project network element size: # of total Bays 16 – 20/Above 200 km 	<p>Known Risks:</p> <ul style="list-style-type: none"> Compulsory acquisition: High/BAU Outage restrictions: High/BAU Project complexity: Partly complex Environmental offset risks: High Others: BAU <p>Unknown risks: Class 5b</p>
H-Dapto	<p>As per Option H-Newcastle above</p> <ul style="list-style-type: none"> Project network element size: # of total Bays 11 – 15 / 100 to 200 km 	<p>As per Option H-Newcastle above</p>
Option 6a	<p>As per Option 2b except:</p> <ul style="list-style-type: none"> Project network element size: # of total Bays 11 – 15 / Above 200 km Land Use: Developed area 	<p>As per Option 4 above</p>
Option 6b	<p>As per Option 6a above</p>	<p>As per Option 4 above</p>

3.8 Southern New South Wales to Central New South Wales

Summary				
<p>The transmission network between Southern New South Wales (SNSW) and Central New South Wales (CNSW) provides access for the hydroelectric generation in the Snowy mountains, renewable generation in SNSW, and import from Victoria and South Australia to New South Wales major load centres.</p> <p>HumeLink is a proposed transmission network augmentation that reinforces the New South Wales southern shared network to increase transfer capacity to New South Wales load centres. This was identified as an actionable ISP project in the 2022 ISP. Transgrid has completed the RIT-T process for this project and early works funding has been approved by the AER.</p> <p>Subsequent to HumeLink, three options are proposed to increase the maximum network transfer capability between SNSW and CNSW to access increased import from Victoria and South Australia with increased generation in SNSW to NSW major load centres.</p>				
Existing network capability				
<p>The maximum transfer capability from SNSW to CNSW is 2,700 MW at peak demand and summer typical and 2,950 winter reference periods. The maximum transfer capability is limited by thermal capacity of Yass– Marulan or Crookwell–Bannaby 330 kV lines following a credible contingency.</p> <p>The maximum transfer capability from CNSW to SNSW is 2,320 MW at peak demand and summer typical and, 2,590 MW at winter reference periods. The maximum transfer capability is limited by thermal capacity of Yass–Canberra or Marulan–Yass⁶² or Gullen Range–Bannaby 330 kV lines following a credible contingency</p>				
Augmentation options				
Description	Additional network capacity (MW)	Expected cost (\$ million)	New easement length (km)	Lead time
<p>Option 1 (HumeLink):</p> <ul style="list-style-type: none"> • New Wagga Wagga 500/330 kV substation and 330 kV double-circuit connection to the existing Wagga Wagga 330 kV substation. • Three new 500 kV transmission lines: <ul style="list-style-type: none"> - Between Maragle and Bannaby 500 kV substations. - Between Maragle and new Wagga Wagga 500 kV substations. - Between new Wagga Wagga and Bannaby 500 kV substations. • Three 500/330 kV 1,500 MVA transformers at Maragle. • Two 500/330 kV 1,500 MVA transformers at new Wagga Wagga. • 500 kV Line shunt reactors at the ends of Maragle – Bannaby, Maragle – new Wagga Wagga and new Wagga Wagga – Bannaby 500 kV lines. <p><i>Provided by Transgrid – see Section 1.2.</i></p>	2,200 ⁶³ N6+N7: 2,200 (N6: 1,500), N5: 800	4,892 ⁶⁴ (June 2023 dollars) Class 3 (-5% to +12%)	630	Short
<p>Option 2:</p> <ul style="list-style-type: none"> • A 2,000 MW bi-pole overhead transmission line from locality of Bannaby to locality of Wagga Wagga. • A new 2,000 MW bipole converter station in locality of Bannaby. 	2,000 (both directions SNSW to CNSW) N6: 2,000	2,450 Class 5b (± 50%)	260	Long

⁶² Upgrading of Marulan – Yass and Marulan – Collector – Yass 330 kV transmission lines were included in limit assessment.

⁶³ Limit from Transgrid’s Project Assessment Conclusions Report is 2,570 MW based on a lower Victoria to New South Wales transfer than that used in the ISP.

⁶⁴ Transgrid. At <https://www.transgrid.com.au/media/rxancvmx/transgrid-humelink-pacr.pdf>.

<ul style="list-style-type: none"> A new 2,000 MW bipole converter station in locality of Wagga Wagga. AC network connection between new HVDC converter station in the locality of Bannaby and the existing Bannaby 500 kV substation. AC network connection between HVDC converter station in the locality of Wagga Wagga and a future Wagga Wagga 500 kV substation. <p><i>Pre-requisite: HumeLink</i></p>				
<p>Option 3:</p> <ul style="list-style-type: none"> An additional new 500 kV double-circuit line from Dinawan to Near Wagga Wagga. An additional new 500 kV double-circuit line from Near Wagga Wagga to Bannaby. 4 additional new 500/330/33 kV 1,500 MVA transformers at Dinawan. <p><i>Pre-requisite: HumeLink, VNI West, SNW Southern 500 kV loop.</i></p>	<p>6,000 (both directions SNSW to CNSW) REZ N5+N6: 6,000</p>	<p>3,014 Class 5b (± 50%)</p>	<p>481</p>	<p>Long</p>
<p>Option 4:</p> <ul style="list-style-type: none"> An additional new 500 kV single-circuit line from Dinawan to Near Wagga Wagga. An additional new 500 kV single-circuit line from Near Wagga Wagga to Bannaby. 2 additional new 500/330/33 kV 1,500 MVA transformers at Dinawan. <p><i>Pre-requisite: HumeLink, VNI West, SNW Southern 500 kV loop.</i></p>	<p>3,000 (both directions SNSW to CNSW) REZ N5+N6: 3,000</p>	<p>2,370 Class 5b (± 50%)</p>	<p>481</p>	<p>Long</p>
Adjustment factors and risk				
Option	Adjustment factors applied	Known and unknown risks applied		
Option 1	<ul style="list-style-type: none"> Cost estimate provided by Transgrid. 	<ul style="list-style-type: none"> Cost estimate provided by Transgrid. 		
Option 2	<ul style="list-style-type: none"> Land Use: Developed area/Grazing Jurisdiction: NSW – Southern Project network element size: # of total Bays above 31/applicable for HVDC converter station project/Above 200 km Location (regional/distance factors): Regional/Urban Delivery timetable: Long 	<p>Known Risks:</p> <ul style="list-style-type: none"> Compulsory acquisition: High/BAU Cultural heritage: High/BAU Outage restrictions: High/BAU Project complexity: Highly complex Environmental offset risks: High Others: BAU <p>Unknown risks: class 5b</p>		
Option 3	<p>As per Option 2 except:</p> <ul style="list-style-type: none"> Project network element size: # of total Bays 6 – 10/Above 200 km 	<p>As per Option 2 except:</p> <ul style="list-style-type: none"> Project complexity: BAU 		
Option 4	<p>As per Option 2 except:</p> <ul style="list-style-type: none"> Project network element size: # of total Bays 1 – 5/Above 200 km 	<ul style="list-style-type: none"> As per Option 2 except: Project complexity: BAU 		

3.9 Victoria to Southern New South Wales

Summary				
<p>VNI West was determined to be an actionable ISP project In the 2020 ISP and 2022 ISP, and a RIT-T for this project is in progress. RIT-T proponents are AEMO Victorian Planning (AVP) and Transgrid.</p> <p>The 2022 ISP identified VNI West (via Kerang) as the ISP candidate option in the ODP. Since publication of 2022 ISP, AVP and Transgrid jointly released VNI West Consultation Report – Options Assessment⁶⁵ which proposes Option 5 as the preferred option. This option connects Bulgana and Dinawan via a new terminal station near Kerang. This option includes relocation of the Western Renewable Link (WRL) proposed terminal station from north of Ballarat to Bulgana and the uprate of the proposed WRL transmission line from north of Ballarat to Bulgana from 220 kV to 500 kV.</p> <p>AEMO has based its analysis on Option 5A. This option was presented as the <i>preferred option</i> in AEMO Victoria Planning's Project Assessment Conclusions Report published in May 2023.</p>		<p>The map illustrates the proposed Option 1 flow path. It starts at Melbourne (indicated by a black dot), goes north to Ballarat, then northeast to Kerang, and finally east to Wagga Wagga. A pink line connects these points, with a label 'Option 1' at the end. The map also shows existing infrastructure like the WRL and various transmission lines. A 'CONCEPTUAL' watermark is visible across the map.</p>		
Existing network capability				
<p>Transfer capability of future options are modelled with VNI Minor upgrade and Victoria System Integrity Protection Scheme (SIPS) with battery storage for increased transfer capability from SNSW to Victoria.</p> <p>Victoria to SNSW maximum transfer capability is 870 MW at peak demand and 1,000 MW at summer typical and winter reference periods. The maximum transfer capability is limited by voltage stability or transient stability limit.</p> <p>The maximum transfer capability from SNSW to Victoria is 400 MW at peak demand, summer typical and winter reference periods. This is limited by voltage stability limit. Victoria's SIPS allows to operate the 330 kV line between South Morang and Murray at higher thermal capacity for a short period following a critical contingency.</p>				
Augmentation options				
Description	Additional network capacity (MW)	Expected cost (\$ million)	New easement length (km)	Lead time
<p>Option 1 (VNI West)⁶⁶:</p> <ul style="list-style-type: none"> A new 500 kV double-circuit overhead line from Bulgana to near Kerang to Dinawan. Series compensation on both 500 kV lines between Bulgana to near Kerang. Upgrade Dinawan – near Wagga Wagga double-circuit line from 330 kV to 500 kV operation (lines build at 500 kV as part of PEC). Establish Dinawan 500 kV switchyard with two 500/330 kV 1,500 MVA transformers. New terminal station near Kerang with two 500/220 kV 1,000 MVA transformers. 220 kV connections from the new terminal station near Kerang to the existing 220 kV lines near Kerang. Modular power flow controllers to prevent overloading on 330 kV lines between Upper/Lower Tumut and South Morang and 220 kV lines between Dederang and Thomastown. 	<p>North: +1,935 South: +1,669 V2: +1,580 V3 (WRL timing): +1,460 V3 (WRL and VNI timing): +200 N5: +900</p>	<p>3,499⁶⁷ (2020-21 dollars) (Cost is inclusive of \$315m WRL project) Class 4 (± 30%)</p>	459	Long

⁶⁵ VNI West Project Assessment Conclusions Report, at https://aemo.com.au/-/media/files/electricity/nem/planning_and_forecasting/victorian_transmission/vni-west-rit-t/reports-and-updates/vni-west-pacr-volume-1.pdf?la=en.

⁶⁶ Scope and costs updated based on VNI West Project Assessment Conclusions Report.

⁶⁷ For ISP modelling, AEMO will apply a cost of \$3,614 million for VNI West. This is determined by subtracting the cost of WRL from the quoted project cost in 2020-21 dollars, and converting to real 2023 dollars.

<ul style="list-style-type: none"> • 500 kV line shunt reactors at both ends of the three following 500 kV circuits: (i) Bulgana – near Kerang, (ii) near Kerang – Dinawan and (iii) Dinawan – near Wagga Wagga. • Two new 500 kV bays and line exits with a total of two 500 kV line shunt reactors at the Bulgana Terminal Station. • Up to +/- 400 MVAr dynamic reactive compensation at the new 220 kV terminal station near Kerang. • Approximately 100 MVAr 500 kV switched bus connected reactor at Sydenham. <p><i>Pre-requisite:</i> WRL 2x500 kV lines from North Sydenham to Bulgana and 2x500/220 kV 1,000 MVA transformers at Bulgana. <i>Provided by AEMO (Victoria Planning) – see Section 1.2.</i></p>				
Adjustment factors and risk				
Option	Adjustment factors applied		Known and unknown risks applied	
Option 1	<ul style="list-style-type: none"> • Cost estimate provided by Transgrid and AEMO Victoria Planning. 		<ul style="list-style-type: none"> • Cost estimate provided by Transgrid and AEMO Victoria Planning. 	

3.10 Tasmania to Victoria

Summary				
<p>Marinus Link will deliver two new high voltage direct current (HVDC) cables connecting the Tasmania and Victoria electricity networks, each with 750 MW of transfer capacity and associated high voltage alternating current (HVAC) transmission.</p> <p>Marinus Link is intended to be connected in the Burnie area in Tasmania and in the Hazelwood area in Victoria. This project also includes HVAC transmission network developments within the North West Tasmanian electricity network.</p> <p>Marinus Link was identified as an actionable ISP project in the 2022 ISP. TasNetworks has completed a RIT-T for this network augmentation. The project assessment conclusions report (PACR), the third and final report of the RIT-T, was published in June 2021⁶⁸. TasNetworks is currently undertaking community engagement, design and approvals on the proposed cable route and transmission lines.</p>				
Existing network capability				
<p>The transfer capacity between Tasmania and Victoria is limited by the thermal capability of Basslink (HVDC system between Tasmania and Victoria). Transfer capacity between Tasmania and Victoria is limited to 462 MW (as measured at the receiving end) in both directions at times of peak demand, summer typical and winter reference periods⁶⁹.</p>				
Augmentation options				
Description	Additional network capacity (MW)	Expected cost (\$ million) ⁷⁰	New easement length (km)	Lead time
<p>Option 1 (Marinus Link – Stage 1)</p> <ul style="list-style-type: none"> • A 750 MW monopole HVDC link between Burnie area in Tasmania and Hazelwood area in Victoria. • A new 750 MW HVDC monopole converter station in Burnie area. • A new 750 MW HVDC monopole converter station in Hazelwood area. • A new 220 kV switching station at Heybridge adjacent to the converter station. • A new 220 kV switching station at Staverton. • A new double-circuit 220 kV transmission line from Staverton to Heybridge via Hampshire and Burnie. • A new 220 kV double-circuit line from Palmerston to Sheffield with decommissioning of existing the single-circuit line. • Cut-in both Sheffield-Mersey Forth double-circuit 220 kV lines at Staverton. • Capacity increase of the four Sheffield–Staverton 220 kV transmission circuits. • A new 500 kV connection from converter station in Hazelwood area. • Decommission existing Sheffield – Burnie 220 kV line. 	<p>Marinus Link: 750 MW in both directions.</p> <p>Basslink and Marinus Link Stage 1 combined⁷¹: VIC to TAS 962 MW TAS to VIC 1,212 MW</p>	<p>2,380⁷² (June 2021 dollars) Class 4 (±30%)</p>	356	July 2029

⁶⁸ TasNetworks. Project Marinus PACR. At <https://www.marinuslink.com.au/wp-content/uploads/2021/06/Project-Marinus-RIT-T-PACR.pdf>.

⁶⁹ In 2022 ISP, 478 MW was applied in both directions. 462 MW transfer in both directions is sourced from Market bids.

⁷⁰ Cost estimates are sourced from TasNetworks.

⁷¹ Combined transfer limit from VIC to TAS 462+500=962 MW. This is on an assumption that largest single contingency in Tasmania capped at 500 MW.

⁷² Presented in real 2023 dollars, this cost would be \$2,701 million. This value will be applied in the 2024 ISP as opposed to the value received from the proponent in 2021 dollars.

<ul style="list-style-type: none"> Open Sheffield – Burnie 110 kV double circuit line and establish Burnie – Emu Bay 110 kV double circuit line (radial line) and another radial double circuit line having two circuits (Sheffield – Ulverstone and Sheffield – Paloona – Ulverstone) <p><i>Provided by TasNetworks – see Section 1.2.</i></p>				
<p>Option 2 (Marinus Link – Stage 2)</p> <ul style="list-style-type: none"> An additional 750 MW monopole HVDC link between Burnie area in Tasmania and Hazelwood area in Victoria. An additional new 750 MW HVDC monopole converter station in Burnie area. An additional new 750 MW HVDC monopole converter station in Hazelwood area. A new double-circuit 220 kV transmission line from Heybridge to Sheffield. A new 500 kV connection from converter station in Hazelwood area. <p><i>Pre-requisite: TAS-VIC Option 1 (Marinus Link – Stage 1)</i> <i>Provided by TasNetworks – see Section 1.2.</i></p>	<p>Marinus Link: 750 MW in both directions.</p> <p>Basslink and Marinus Link Stages 1 and 2 combined⁷³:</p> <p>VIC to TAS 1,712 MW TAS to VIC 1,962 MW</p>	<p>1,402⁷⁴ (June 2021 dollars) (±30%)</p> <p>Note: This stage is estimated to cost an additional \$600 million if completed more than 3 years after stage 1. Class 4 (±30%)</p>	<p>43</p>	<p>July 2031</p>
Adjustment factors and risk				
Option	Adjustment factors applied	Known and unknown risks applied		
Options 1 and 2	<ul style="list-style-type: none"> Refer the TasNetworks Marinus Link Cost Estimate Report prepared by Jacobs⁷⁵. 			

⁷³ Combined transfer limit from VIC to TAS 462+625+625=1,712 MW. This is on an assumption that largest single contingency in Tasmania capped at 500 MW. Following an outage of Marinus Link cable, the remaining Marinus Link cable increases the transfer by 125 MW to its maximum transfer capacity of 750 MW. This will limit reduction in transfer from VIC to TAS to 500 MW.

⁷⁴ For more information on the additional cost of Marinus Link if the second stage is delayed, refer to section 4 of the Addendum to the Draft 2022 ISP, at <https://aemo.com.au/-/media/files/major-publications/isp/2022/addendum/addendum-to-the-draft-2022-isp.pdf?la=en>.

⁷⁵ At <https://www.marinuslink.com.au/wp-content/uploads/2021/06/Attachment-3-Jacobs-cost-estimate-report.pdf>.

3.11 Victoria to South East South Australia

Summary				
<p>The Victoria (VIC) to South East South Australia (SESA) corridor represents a Victoria – South Australia interconnector through Heywood Terminal Station and South East Substation.</p> <p>Should a larger amount of load, generation or storage be developed in South Australia, transmission augmentation options for this flow path may be required. These development options would facilitate increased transmission of renewable energy and supply from energy storage in SESA REZ to Victoria.</p> <p>At present this card includes the South Australia options to augment this flow path, please refer to South West Victoria (V4) REZ (section 4.6.4) for relevant expansion options in the Victorian side of this flow path.</p>		<p>The map shows the geographical context of the flow path. Adelaide is marked with a black dot in the north, and Mount Gambier is marked with a grey dot in the south. A vertical dashed line represents the border between Victoria and South Australia. Two purple lines, labeled 'Option 1 & 2', originate from Adelaide and extend southwards, crossing the border into South Australia. The map is overlaid with a 'CONCEPTUAL' watermark.</p>		
Existing network capability				
<p>VIC to SESA maximum transfer capability is 650 MW at peak demand, summer typical and winter reference periods. The maximum transfer capability is limited by Thermal capacity of Heywood-South East 275 kV line or transient stability limit for loss of the largest generator in South Australia or transient stability limit of loss of South East – Tailern Bend 275 kV line.</p> <p>SESA to VIC maximum transfer capability is 650 MW at peak demand, summer typical and winter reference periods. The maximum transfer capability is limited by Oscillatory stability limit.</p>				
Augmentation options				
Description	Additional network capacity (MW)	Expected cost (\$ million)	New easement length (km)	Lead time
<p>Option 1:</p> <ul style="list-style-type: none"> Build a 275 kV double-circuit line from an offshore collection node in South East SA to Heywood terminal station. 2x 1,000 MVA 500/275 kV transformers at Heywood terminal station. New offshore collection terminal station. 	<p>1,640 (VIC to SESA) 1,640 (SESA to VIC) S1: 1,640 V4: 0 (Transfer limits between Heywood and Sydenham are modelled by a REZ group constraint SWV1)</p>	<p>892 Class 5b (±50%)</p>	240	Long
<p>Option 2:</p> <ul style="list-style-type: none"> Build a 500 kV double-circuit line from an offshore collection node in South East SA to Heywood Terminal Station. New offshore collection terminal station. 2 x 1,500 MVA 500/275 kV transformers at offshore collection terminal station. 	<p>3,000 (VIC to SESA) 3,000 (SESA to VIC) S1: 3,000 V4: 0 (Transfer limits between Heywood and Sydenham are modelled by a REZ group constraint SWV1)</p>	<p>1,363 Class 5b (±50%)</p>	240	Long
Adjustment factors and risk				
Option	Adjustment factors applied	Known and unknown risks applied		
Option 1	<ul style="list-style-type: none"> Land Use: Grazing Jurisdiction: SA – South East/VIC – South West 	<ul style="list-style-type: none"> Known risks: BAU Unknown risks: Class 5b 		

Flow paths

	<ul style="list-style-type: none">• Project network element size: # of total Bays 6 – 10/Above 200 km• Location (regional/distance factors): Regional• Delivery timetable: Long	
Option 2	As per Option 1.	As per Option 1.

3.12 South East South Australia to Central South Australia

Summary				
<p>The South East South Australia (SESA) to Central South Australia (CSA) corridor represents a portion of the Victoria – South Australia interconnector through Heywood Terminal Station and South East Substation. Development options on this corridor include access of increased renewable generation and energy storage in South East REZ to Adelaide load centre and to New South Wales through the New South Wales – South Australia interconnector through Bundy and Buronga.</p>				
Existing network capability				
<p>SESA to CSA maximum transfer capability is 650 MW at peak demand, summer typical and winter reference periods. The maximum transfer capability is limited transient stability limit for loss of the largest generator in South Australia or transient stability limit of loss of South East – Taillem Bend 275 kV line.</p> <p>CSA to SESA maximum transfer capability is 650 MW at peak demand, summer typical and winter reference periods. The maximum transfer capability is limited by Oscillatory stability limit.</p>				
Augmentation options				
Description	Additional network capacity (MW)	Expected cost (\$ million)	New easement length (km)	Lead time
<p>Option 1:</p> <ul style="list-style-type: none"> Build a 500 kV double-circuit line from Bunday terminal station to an offshore collection node in South East SA. 2 x 1,500 MVA 500/275 kV transformers at Bunday terminal station. New offshore collection terminal station. 2 x 1,500 MVA 500/275 kV transformers at offshore collection terminal station. 	<p>3,000 (SESA to CSA) 3,000 (CSA to SESA) S1: 3,000 S2: 0</p>	<p>1,807 Class 5b (±50%)</p>	290	Long
Adjustment factors and risk				
Option	Adjustment factors applied	Known and unknown risks applied		
Option 1	<ul style="list-style-type: none"> Land Use: Grazing Jurisdiction: SA – Adelaide and Fleurieu/SA – South East Project network element size: # of total Bays 6 – 10/Above 200 km Location (regional/distance factors): Regional Delivery timetable: Long 	<ul style="list-style-type: none"> Known risks: BAU Unknown risks: Class 5b 		

4 Renewable Energy Zones

REZs are areas in the NEM where clusters of large-scale renewable energy can be efficiently developed, promoting economies of scale in high-resource areas, and capturing important benefits from geographic and technological diversity in renewable resources. AEMO's ISP Methodology⁷⁶ provides an overview of how AEMO uses REZ augmentation options and costs in the ISP modelling.

Section 4 outlines network augmentation options to increase the transfer capacity⁷⁷ of REZs. REZ network augmentations are designed to allow connection of new generation to the existing network and overcome expected network congestion. The following information is presented for each augmentation option:

- A description of the option.
- The expected increase in transfer capacity.
- The project cost, including the class of the estimate and associated accuracy.
- An overview of characteristics which are key cost drivers.

Where network congestion can result due to the combined output from multiple REZs or where there are significant transmission limits that apply to only a subset of generation within a REZ, additional network limits and potential augmentations are provided.

Cost estimates for REZ augmentation options cover the network expansion to establish the REZ. These costs are distinct from the costs associated with individual generator connections, which are considered in Section 5.

Section 4 provides the following information:

- A map of the candidate REZs and network augmentation options for the 2024 ISP (Figure 18).
- A legend and explanation of tables (Section 4.1).
- New South Wales REZ expansion options (Section 4.2).
- Queensland REZ expansion options (Section 4.3).
- South Australia REZ expansion options (Section 4.4).
- Tasmania REZ expansion options (Section 4.5).
- Victoria REZ expansion options (Section 4.6).

⁷⁶ AEMO's current ISP Methodology is at <https://www.aemo.com.au/consultations/current-and-closed-consultations/isp-methodology>. AEMO is also consulting on updates to the ISP Methodology, at <https://aemo.com.au/consultations/current-and-closed-consultations/consultation-on-updates-to-the-isp-methodology>.

⁷⁷ The "transfer capacity" of a REZ refers to the amount of generation that can be exported from a REZ.

Figure 18 Candidate REZs and REZ augmentation options for 2023 Transmission Expansion Options Report

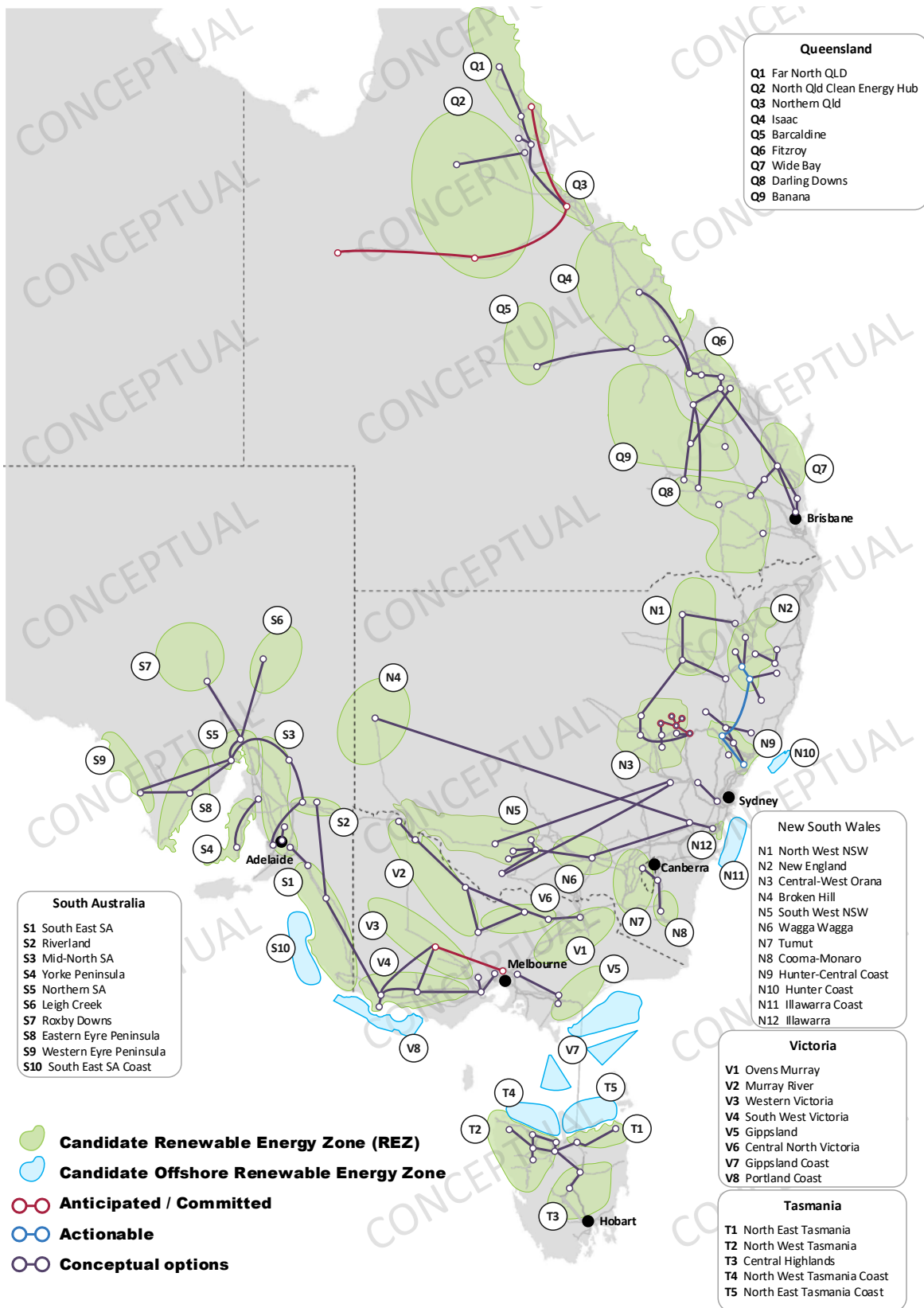

4.1 Legend and explanation of tables

The tables in Section 3 and Section 4 provide an overview of the characteristics of each network development option. The following template explains the criteria and terminology used in the tables.

Summary	
A brief description of the existing network is provided (for example, network capacity, projects to increase capacity, findings from the 2022 ISP).	
Existing network capability	
<p>For flow paths, this is the approximate maximum forward and reverse flow capability between the regions or sub-regions. These capabilities are represented by nominal transfer capacity when there are no transmission network outages in the local area. The capacity is sourced from recent historical data.</p> <p>For REZs, this is the capacity of the specific area of the network to allow connection of variable renewable energy (VRE) prior to curtailment being anticipated.</p> <p>The limit is the notional maximum transfer limit at the time of "Summer 10% probability of exceedance (POE) demand" (referred to as 'peak demand'), "Summer Typical", and "Winter Reference" in the importing region or sub-region, as outlined in the ISP Methodology. The figure quoted is the minimum of the following required limits: transmission asset thermal capacity; voltage stability; transient stability; oscillatory stability; and system strength and inertia.</p>	
Augmentation options – these include the conceptual design, capability, cost and timing for flow path augmentation options	
Additional network capacity (MW)	This is the additional network transfer capacity for each of the identified options and based on power system studies undertaken by AEMO or TNSPs. For flow paths the direction of power flow is stated. For REZs, the power flow is always in one direction from the REZ to the network.
Cost	<p>The costs are based on 2022 figures in (\$ million) but have been presented in real 2023 dollars. All cost estimates are indicative and prepared using AEMO's Transmission Cost Database, except for projects currently progressing through the RIT-T (or another regulatory process) or where preparatory activities were required in the 2022 ISP. Cost estimates for projects which are currently progressing through the RIT-T (or another regulatory process), or where preparatory activities were required in the 2022 ISP, are sourced from the relevant TNSP or NEM jurisdictional body.</p> <p>Costs shown in this report are rounded to two significant figures for readability. Non-rounded costs from the Transmission Cost Database, TNSPs or jurisdictional bodies will be used in the ISP modelling, and will be documented in the 2023 IASR Workbook.</p>
Cost classification	This is based on either AEMO's Transmission Cost Database or TNSPs' cost estimates information based on the ACE Cost Estimate Classification System as referenced in Section 2.1.
Lead time	Lead times represent the likely minimum time for service from the date of publication of the final 2024 ISP. The lead time includes regulatory justification and approval, relevant community engagement and planning approvals, procurement, construction, commissioning, and inter-network testing. Lead times are categorised as short (3-5 years), medium (6-7 years), or long (beyond 7 years).
Adjustment factors and risk – notes the adjustment factors, known risks and unknown risks applied to the option, for those estimates which were developed with the <i>Transmission Cost Database</i>.	
<p>Adjustment factors:</p> <ul style="list-style-type: none"> • Location (urban, regional and remote). • Greenfield/brownfield (greenfield, brownfield and partly brownfield) – greenfield is chosen unless otherwise specified. • Land use (desert, scrub, grazing and developed area). • Terrain (flat/farmland, mountainous and hilly/undulating). • Jurisdiction (state and Rural Bank defined sub-region⁷⁸). • Project network element size (transmission line length, project size). • Delivery timeframe (optimum, tight, long). • Contract delivery model (EPC contract, D&C contract) – EPC contract is chosen unless otherwise specified. • Proportion of environmentally sensitive areas (None, 25%, 50%, 75% and 100%). • Location wind loading zones (cyclone and non-cyclone regions) – non-cyclone region is chosen unless otherwise specified. 	
<p>Known risk: where the risks are identified but ultimate value is not known. There are nine known risk factors:</p> <ul style="list-style-type: none"> • Compulsory acquisition (BAU, low and high). 	

⁷⁸ Rural Bank. Australian Farmland Values. 2022. At <https://www.ruralbank.com.au/siteassets/documents/publications/flv/afv-national-2022.pdf>.



- Cultural heritage (BAU, low and high).
 - Environmental offset risks (BAU, low, high, very high, and observed maximum).
 - Geotechnical findings (BAU, low and high).
 - Macroeconomic influence (BAU, increased uncertainty and heightened uncertainty).
 - Market activity (BAU, tight and excess capacity).
 - Outage restrictions (BAU, low and high).
 - Project complexity (BAU, partly complex and highly complex).
 - Weather delays (BAU, low and high).
- Unknown risk: where the risk has not been identified but industry experience indicates these could occur:
- Scope and technology (Class 5b, Class 5a and Class 4).
 - Productivity and labour cost (Class 5b, Class 5a and Class 4).
 - Plant procurement cost (Class 5b, Class 5a and Class 4).
 - Project overhead (Class 5b, Class 5a and Class 4).

4.2 New South Wales

4.2.1 North West New South Wales (N1)

Summary				
<p>The North-West New South Wales (NWNSW) REZ is located to the west of the existing QNI. While this zone has high-quality solar resources, the wind resource is estimated to be mostly inadequate for wind farm development.</p> <p>If generation significantly increases in NWNSW and New England REZs, increased connection capacity between the two REZs may be required. The sharing of resources across the network augmentation will allow for better transmission utilisation and reduction in transmission build.</p>				
Existing network capability				
<p>The existing 132 kV network is weak and would require significant network upgrades to accommodate VRE greater than the transmission network limit of approximately 170 MW.</p>				
Augmentation options				
Description	Additional network capacity (MW)	Expected cost (\$ million)	New easement length (km)	Lead time
<p>Option 1:</p> <ul style="list-style-type: none"> Two new 500 kV circuits from Orana REZ to locality of Gilgandra to locality of Boggabri to locality of Moree. A new single 500 kV circuit from Orana REZ to Wollar. New 500/330 kV substations in locality of Boggabri and Moree. A new 500 kV switching station in locality of Gilgandra. A new 330 kV single-circuit from Sapphire to locality of Moree. A new 330 kV circuit from Tamworth to locality of Boggabri. Line shunt reactors at both ends of Orana REZ-locality of Gilgandra, locality of Gilgandra-locality of Boggabri, locality of Boggabri-locality of Moree 500 kV circuits. 	1,660	4,684 Class 5b (±50%)	810	Long
Adjustment factors and risk				
Option	Adjustment factors applied	Known and unknown risks applied		
Option 1	<ul style="list-style-type: none"> Land Use: Grazing Jurisdiction: NSW – Northern Project network element size: # of total Bays above 31/applicable for HVDC converter station project/Above 200 km Location (regional/distance factors): Remote Delivery timetable: Long 	<p>Known Risks:</p> <ul style="list-style-type: none"> Compulsory acquisition : High/BAU Project complexity : Partly complex Environmental offset risks : High Others: BAU <p>Unknown risks: Class 5b</p>		

4.2.2 New England (N2)

Summary				
<p>New England REZ is located to the east of and along the existing QNI. The capacity of this REZ is supported by extensive Northern NSW – Central NSW corridor network options and it will be part of New England REZ infrastructure development.</p> <p>This REZ has moderate to good wind and solar resources in close proximity to the 330 kV network. Interest in the area includes large scale solar and wind generation as well as pumped hydro generation.</p>				
Existing network capability				
<p>The existing network capacity, following completion of the committed QNI Minor upgrade, is limited by transient and voltage stability on the circuits between Bulli Creek, Sapphire and Dumaresq. Thermal limits on the 330 kV circuits between Armidale, Tamworth, Muswellbrook and Liddell can also restrict flows on this network.</p>				
Augmentation options ⁷⁹				
Description	Additional network capacity (MW)	Expected cost (\$ million)	New easement length (km)	Lead time
<p>Option 1:</p> <ul style="list-style-type: none"> New 330 kV South (Hub3) and East (Hub 4) switching stations. New 330 kV double-circuit line between Hub 1 and Hub 3. New 330 kV double-circuit line between Hub 1 and Hub 4. <p><i>Pre-requisite: CNSW-NNSW Option 1</i></p>	1,000	370 Class 5b (±50%)	60	Medium
<p>Option 2:</p> <ul style="list-style-type: none"> New North switching station and cuts into Sapphire – Armidale and Dumaresq – Armidale line. New 500 kV built and initially 330 kV operated double-circuit line from North switching station to Hub 5. Augment Hub 5 with one additional 500/330 kV transformer. New 500 kV double-circuit line, strung on one side between Hub 5 to Hub 1. New 330 kV DCST line from Hub 8 to Hub 5. New Hub 8 switching station. <p><i>Pre-requisite: CNSW-NNSW Option 3</i></p>	1,500	1,004 Class 5b (±50%)	140	Long
<p>Option 3:</p> <ul style="list-style-type: none"> New Hub 9 switching station. Establish a new Lower Creek 330/132 kV substation with 1 x 330/132 kV 375 MVA transformer. Rebuild part of Line 965 as 330 kV double-circuit from Armidale to Lower Creek. Relocate existing 132 kV 200 MVA phase shift transformer on Line 965 from Armidale to Lower Creek. New 330 kV double-circuit from Lower Creek to Hub 9. Cut-in of Line 965 at new Lower Creek substation 	900	647 Class 5b (±50%)	20	Medium
Adjustment factors and risk				
Option	Adjustment factors applied	Known and unknown risks applied		

⁷⁹ For practicality of ISP modelling, AEMO has only included a sub-set of the options for this REZ from the May 2023 Final Network Infrastructure Strategy released by EnergyCo. This does not provide an indication of any ultimate option selection through the New South Wales REZ regulatory process.

<p>Option 1</p>	<ul style="list-style-type: none"> • Land Use: Grazing • Jurisdiction: NSW – Northern • Project network element size: 10 to 100 km/# of total Bays 6 – 10 • Location (regional/distance factors): Remote • Delivery timetable: Long 	<p>Known Risks:</p> <ul style="list-style-type: none"> • Compulsory acquisition : High/BAU • Environmental offset risks : High • Market activity : Tight • Others: BAU <p>Unknown risks: Class 5b</p>
<p>Option 2</p>	<ul style="list-style-type: none"> • Land Use: Grazing/Developed area/Scrub • Jurisdiction: NSW – Central/NSW – Northern • Project network element size: # of total Bays 16 – 20/100 to 200 km • Location (regional/distance factors): Regional/Urban • Delivery timetable: Long 	<p>Known Risks:</p> <ul style="list-style-type: none"> • Compulsory acquisition : High/BAU • Outage restrictions : High/BAU • Project complexity : Partly complex • Environmental offset risks : High • Others: BAU <p>Unknown risks: Class 5b</p>
<p>Option 3</p>	<ul style="list-style-type: none"> • Land Use: Developed area/Scrub • Jurisdiction: NSW – Northern • Project network element size: # of total Bays 11 – 15/100 to 200 km • Location (regional/distance factors): Regional • Delivery timetable: Long 	<p>As per Option 2 above</p>

4.2.3 Central-West Orana (N3)

Summary				
<p>The Central-West Orana REZ is electrically close to the Sydney load centre and has moderate wind and solar resources.</p> <p>Central-West Orana REZ has been identified by the New South Wales Government as the state's first pilot REZ⁸⁰.</p> <p>The NSW <i>Electricity Infrastructure Investment Act 2020</i> legislates the REZ be declared with an intended 3,000 MW of additional transmission network capacity.</p>				
Existing network capability				
<p>The project to establish the Central-West Orana REZ is considered anticipated. As such the existing network capability is assumed to be approximately 3,900 MW, incorporating the Central-West Orana REZ transmission link project (3,000 MW), as well as existing network capability (900 MW).</p>				
Augmentation options ⁸¹				
Description	Additional network capacity (MW)	Expected cost (\$ million)	New easement length (km)	Lead time
<p>Central-West Orana REZ transmission link</p> <ul style="list-style-type: none"> New Merotherie 500/330 kV substation with 3 x 500/330/33 kV 1,500 MVA transformers. New 330 kV Uarbry East, Uarbry West, Elong Elong switching stations. New 500 kV Wollar switching station. 2 x 500 kV double-circuit line from Wollar to Merotherie. 330 kV double-circuit line from Merotherie to Uarbry East. 330 kV double-circuit from Merotherie to Uarbry West. 2 x 500 kV double-circuit and initially operated at 330 kV from Merotherie to Elong Elong. 5 x 100 MVA synchronous condensers at Elong Elong switching station. 5 x 100 MVA synchronous condensers at Merotherie substation. Provision of switchbays for future generator connections. An additional 330 kV single-circuit line from Bayswater to Liddell. An additional 330 kV single-circuit line from Mt Piper to Wallerawang. New 330 kV Uungula switching station and cut into Line 79 Wellington – Wollar. 1 x 330 kV DCST from Elong Elong to Uungula with Twin Olive conductor. 2 x 100 MVA synchronous condensers at Uarbry West switching station. 3 x 100 MVA synchronous condensers at Uarbry East switching station. 	3,000	<p>This project is considered to be anticipated and so is not included as an option here.</p> <p>The scope of the project is listed here for context so that the subsequent options can be understood. Option 1 includes expansions and augmentations to this project.</p>		
<p>Option 1:</p> <ul style="list-style-type: none"> Expand Elong Elong substation with 3 x 500/330/33 kV 1,500 MVA transformers. 	3,000	243 Class 5b (±50%)	-	Medium

⁸⁰ See <https://www.energyco.nsw.gov.au/renewable-energy-zones#-centralwest-orana-renewable-energy-zone-pilot->.

⁸¹ For practicality of ISP modelling, AEMO has only included a sub-set of the options for this REZ from the May 2023 Final Network Infrastructure Strategy released by EnergyCo. This does not provide an indication of any ultimate option selection through the New South Wales REZ regulatory process.

<ul style="list-style-type: none"> Operate 4 circuits between Elong Elong and Merotherie to 500 kV. (Pre-requisite: CWO REZ transmission link project) <p>Note: Hunter Transmission Project will be required to get up to 6 gigawatts (GW) total network capacity as pre-requisite.</p> <p>Note: Hunter Transmission Project will be required when the total network capacity is greater than 3 GW as pre-requisite.</p>				
<p>Option 2:</p> <ul style="list-style-type: none"> New 330 kV Stubbo switching station and cuts into Wellington – Wollar. New 330 kV single-circuit line between Wollar and Stubbo. Expand Wollar substation with 330 kV busbar and 1 x 500/300/33 kV 1,500 MVA transformer. 	500	330 Class 5b (±50%)	55	Medium
<p>Option 3:</p> <ul style="list-style-type: none"> New 330 kV Burrendong switching station and cuts into Line Wellington – Mt Piper. New Ungula switching station and cuts into Wollar – Wellington. New 330 kV double-circuit line from Burrendong switching station to Ungula. 	500	273 Class 5b (±50%)	45	Medium
Adjustment factors and risk				
Option	Adjustment factors applied		Known and unknown risks applied	
Option 1	<ul style="list-style-type: none"> Land Use: Grazing Jurisdiction: NSW – Central Project network element size: # of total Bays 1 – 5 Location (regional/distance factors): Regional Delivery timetable: Optimum 		<p>Known Risks:</p> <ul style="list-style-type: none"> Environmental offset risks: High Market Activity: Tight Others: BAU <p>Unknown risks: Class 5b</p>	
Option 2	<p>As per Option 1 except:</p> <ul style="list-style-type: none"> Project network element size: 10 to 100 km/# of total Bays 6 – 10 		<ul style="list-style-type: none"> As per Option 1 	
Option 3	<ul style="list-style-type: none"> As per Option 2 		<ul style="list-style-type: none"> As per Option 1 	

4.2.4 Broken Hill (N4)⁸²

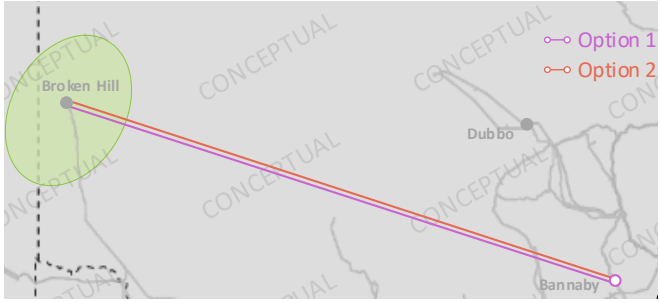
Summary				
Broken Hill REZ has excellent solar resources. It is connected to the New South Wales grid via a 220 kV line from Buronga with an approximate length of 270 km.				
Existing network capability				
Due to the existing utility-scale solar and wind generation projects already operating in this REZ, there is no additional network capacity within this REZ. Further development of new generation development in this REZ requires significant transmission network augmentation due to the distance of the REZ from the main transmission paths of the shared network.				
Augmentation options				
Description	Additional network capacity (MW)	Expected cost (\$ million)	New easement length (km)	Lead time
Option 1: <ul style="list-style-type: none"> 500 kV double-circuit line from Bannaby – Broken Hill (>850 km). Two mid-point switching stations and reactive plant. 	1,750	5,098 Class 5b (±50%)	849	Long
Option 2: <ul style="list-style-type: none"> 500 kV double-circuit HVDC line from Bannaby – Broken Hill (>850 km). New HVDC converter stations at Bannaby and Broken Hill. 	1,750	4,576 Class 5b (±50%)	850	Long
Adjustment factors and risk				
Option	Adjustment factors applied	Known and unknown risks applied		
Option 1	<ul style="list-style-type: none"> Land Use: Grazing Jurisdiction: NSW – Western Project network element size: # of total Bays above 31/applicable for HVDC converter station project/Above 200 km Location (regional/distance factors): Remote/Regional Delivery timetable: Long 	Known Risks: <ul style="list-style-type: none"> Project complexity: Partly complex Environmental offset risks: High Others: BAU Unknown risks: Class 5b		
Option 2	As per Option 1 above except: <ul style="list-style-type: none"> Jurisdiction: NSW – Western/NSW – Central Location (regional/distance factors): Remote 	Known Risks: <ul style="list-style-type: none"> Project complexity: Highly complex Environmental offset risks: High Others: BAU Unknown risks: Class 5b		

⁸² AEMO notes that this REZ is not one of the first five REZs that have been declared by the New South Wales Government under its New South Wales Electricity Infrastructure Roadmap.

4.2.5 South West NSW (N5)

Summary				
<p>The South West NSW REZ has good solar resource and incorporates the Dinawan 330 kV substation that will be built as part of Project EnergyConnect. Further west, the 220 kV links to North West Victoria and Broken Hill. This REZ is one of three REZs which are being targeted for further development under the NSW Electricity Infrastructure Roadmap.</p> <p>Network limits associated with the existing voltage stability limit for loss of the existing Darlington Point to Wagga 330 kV line are represented by the SWNSW1 secondary transmission limit.</p>				
Existing network capability				
<p>Due to the existing utility-scale solar projects already operating within this REZ, there is no additional capacity. Further development of new generation in this REZ requires network augmentation towards the greater Sydney load centre. The capacity within this REZ and ability to transfer energy from the REZ to the main load centres in the greater Sydney area will be improved with the construction of Project EnergyConnect and HumeLink projects. Furthermore, one option for VNI West (Kerang route) would also increase the capacity of this REZ.</p>				
Augmentation options ⁸³				
Description	Additional network capacity (MW)	Expected cost (\$ million)	New easement length (km)	Lead time
<p>Option 1:</p> <ul style="list-style-type: none"> Expand Dinawan 330 kV switching station to 500/330 kV substation with 3 x 500/330/33 kV, 1,500 MVA transformers. Operate 500 kV built and 330 kV operated double-circuit line from Dinawan to Wagga to 500 kV. <p>(Pre-requisite: EnergyConnect and HumeLink)⁸⁴</p>	2,500	1,418 Class 5b (±50%)	-	Long
<p>Option 2:</p> <ul style="list-style-type: none"> New Conargo 330 kV switching station. New 330 kV double-circuit line from Conargo to Dinawan. <p>(Pre-requisite: Dinawan – Wagga 500 kV upgrade)</p>	800	383 Class 5b (±50%)	69	Long
<p>Option 3:</p> <ul style="list-style-type: none"> New Marbins Well 330 kV switching station. New 330 kV DCST line from Mabins Well to Dinawan. <p>(Pre-requisite: Dinawan – Wagga 500 kV upgrade)</p>	1,400	300 Class 5b (±50%)	50	Long
<p>Option 4:</p> <ul style="list-style-type: none"> New The Plains 330 kV switching station. New 330 kV double-circuit line and strung on one side from The Plains to Dinawan. <p>(Pre-requisite: South West REZ Option 1)</p>	1,400	417 Class 5b (±50%)	88	Long
<p>Option 5:</p> <ul style="list-style-type: none"> New Hays Plain 330 kV switching station New Abercrombie 330 kV switching station. New 330 kV double-circuit line from Hays Plain to Abercrombie. New 330 kV double-circuit line from Abercrombie to The Plain. String the other side of 330 kV line from The Plain to Dinawan. 	1,400	1,047 Class 5b (±50%)	280	Long

⁸³ For practicality of ISP modelling, AEMO has only included a sub-set of the options for this REZ from the May 2023 Final Network Infrastructure Strategy released by EnergyCo. This does not provide an indication of any ultimate option selection through the New South Wales REZ regulatory process.

⁸⁴ Option 1 is an alternative to VNI West Project.

<i>(Pre-requisite: South West REZ Option 4)</i>				
SWNSW1 Option 1: <ul style="list-style-type: none"> Establish a new Darlington Point to Dinawan 330 kV transmission line, post Project EnergyConnect. <i>(Pre-requisite: Project EnergyConnect and HumeLink)</i>	600	167 ⁸⁵ Class 5a (± 30%)	90	Short
Adjustment factors and risk				
Option	Adjustment factors applied	Known and unknown risks applied		
Option 1	<ul style="list-style-type: none"> Land Use: Grazing Jurisdiction: NSW – Southern Project network element size: 100 to 200 km/# of total Bays 6 – 10 Location (regional/distance factors): Regional Delivery timetable: Long 	Known Risks: <ul style="list-style-type: none"> Compulsory acquisition: High Cultural heritage: High Outage restrictions: High Project complexity: Partly complex Environmental offset risks: Very high Others: BAU Unknown risks: Class 5b		
Option 2	As per Option 1 except: <ul style="list-style-type: none"> Project network element size: # of total Bays 1 – 5/10 to 100 km 	Known Risks: <ul style="list-style-type: none"> Compulsory acquisition : High Cultural heritage : High Outage restrictions : High Environmental offset risks : Very high Others: BAU Unknown risks: Class 5b		
Option 3	As per Option 2 above	As per Option 2 above		
Option 4	As per Option 2 above	As per Option 2 above		
Option 5	<ul style="list-style-type: none"> Land Use: Grazing Jurisdiction: NSW – Southern Project network element size: # of total Bays 6 – 10/Above 200 km Location (regional/distance factors): Remote/Regional Delivery timetable: Long 	As per Option 2 above		
SWNSW1 Option1	<ul style="list-style-type: none"> Transgrid Project Assessment Conclusions Report RIT-T estimate 	<ul style="list-style-type: none"> Transgrid PACR RIT-T estimate 		

⁸⁵ Cost Estimate from Transgrid PACR at https://www.transgrid.com.au/media/tinisujc/transgrid-pacr_improving-stability-in-sw-nsw.pdf.

4.2.6 Wagga Wagga (N6)⁸⁶

Summary				
This REZ extends to the west of Wagga Wagga and has moderate wind and solar resources.				
Existing network capability				
There is no additional capacity within this REZ due to congestion in the surrounding 330 kV networks. Further development of new generation in this REZ requires network augmentation towards the greater Sydney load centre. Additionally, the capacity within this REZ and ability to transfer energy from the REZ to the main load centres in the greater Sydney area are improved with the proposed HumeLink project. Options shown do not depend upon HumeLink as a pre-requisite.				
Augmentation options				
Description	Additional network capacity (MW)	Expected cost (\$ million)	New easement length (km)	Lead time
Option 1: <ul style="list-style-type: none"> Refer to Section 3.8 (SNSW-CNSW) Option 3 and 4 in the flow paths. 	Refer to Section 3.8			
Adjustment factors and risk				
Option	Adjustment factors applied	Known and unknown risks applied		
Option 1	<ul style="list-style-type: none"> Refer to Section 3.8 (SNSW-CNSW) Option 3 and 4 in the flow paths 			

⁸⁶ AEMO notes that this REZ is not one of the first five REZs that have been declared by the NSW Government under its New South Wales Electricity Infrastructure Roadmap.

4.2.7 Tumut (N7)⁸⁷

Summary				
<p>The Tumut REZ has been identified due to the potential for additional pumped hydro generation in association with Snowy 2.0 and the proposed actionable ISP HumeLink. The HumeLink project will enable the connection of more than 2,000 MW of pumped hydro generation (Snowy 2.0) in the Tumut REZ area.</p>				
Existing network capability				
<p>There is no additional capacity within this REZ. Further development of new generation in this REZ is associated with the HumeLink project. Currently the 330 kV transmission network around Lower and Upper Tumut is congested during peak demand periods. A careful balance of generation from the existing hydro units and flow between Victoria and New South Wales is required to prevent overloads within this area.</p>				
Augmentation options				
Description	Additional network capacity (MW)	Expected cost (\$ million)	New easement length (km)	Lead time
<p>Option 1:</p> <ul style="list-style-type: none"> HumeLink (actionable ISP 2020 project- see Section 3.8). 	<p>2,200(SNSW to CNSW) REZ network limit increase: 1,500 MW in N6, 2,200 MW in N6+N7, 1,000 MW in N5.</p>	<p>See Section 3.8 4,892 (June 2023 dollars) (including \$330 million for early works⁸⁸)</p>		
Adjustment factors and risk				
Option	Adjustment factors applied	Known and unknown risks applied		
Option 1	See Section 3.8			

⁸⁷ AEMO notes that this REZ is not one of the first five REZs that have been declared by the NSW Government under its New South Wales Electricity Infrastructure Roadmap.

⁸⁸ The Australian Energy Regulator has approved early works funding for HumeLink: <https://www.transgrid.com.au/media-publications/news-articles/early-works-funding-approved-for-humelink>

4.2.8 Cooma-Monaro (N8)

Summary				
<p>The Cooma-Monaro REZ has been identified for its pumped hydro potential. This REZ has moderate to good quality wind resources.</p>				
Existing network capability				
<p>The existing 132 kV network connecting Cooma-Monaro REZ to Canberra, Williamsdale and Muryang can accommodate approximately 200 MW of additional generation.</p>				
Augmentation options				
Description	Additional network capacity (MW)	Expected cost (\$ million)	New easement length (km)	Lead time
<p>Option 1:</p> <ul style="list-style-type: none"> 132 kV single-circuit Williamsdale to Cooma-Monaro substation (located near generation interest). 	150	202 Class 5b (±50%)	81	Medium
<p>Option 2:</p> <ul style="list-style-type: none"> 330 kV line Cooma–Williamdale–Stockdill. Two 330/132 kV transformers at Cooma. 	500	512 Class 5b (±50%)	126	Medium
Adjustment factors and risk				
Option	Adjustment factors applied	Known and unknown risks applied		
Option 1	<ul style="list-style-type: none"> Land Use: Grazing Jurisdiction: NSW – South East Project network element size: # of total Bays 1 – 5/10 to 100 km Location (regional/distance factors): Regional Delivery timetable: Long 	<p>Known Risks:</p> <ul style="list-style-type: none"> Environmental offset risks : High Market Activity: Tight Others: BAU <p>Unknown risks: Class 5b</p>		
Option 2	<p>As per Option 1 except:</p> <p>Project network element size: 100 to 200 km/# of total Bays 6 – 10</p>	<p>As per Option 1 above</p>		

4.2.9 Hunter-Central Coast (N9)

Summary				
<p>The Hunter-Central Coast (HCC) REZ has been identified to assist industries to decarbonize and access renewable energy with a mix of solar, onshore and offshore wind energy projects.</p> <p>The REZ has been declared with 1,000 MW of intended network capacity and EnergyCo has been appointed the Infrastructure Planner enabled by the <i>Electricity Infrastructure Investment Act 2020</i>.</p> <p>The capacity of the Hunter-Central Coast REZ is likely to increase over time with the retirement of coal-fired power stations, re-purposing of mining land and the growth of offshore wind.</p>				
Existing network capability				
<p>This REZ is intended to supply SNW and it is assumed that supply to SNW would also include high southbound flows from NNSW to CNSW. The REZ limit is at 400 MW to reflect the limit for supplying SNW.</p>				
Augmentation options				
Description	Additional network capacity (MW)	Expected cost (\$ million)	New easement length (km)	Lead time
<p>Option 1:</p> <ul style="list-style-type: none"> Rebuild the existing Line 83 Liddell–Muswellbrook as 330 kV double-circuit line. 1 x 330 kV double-circuit from East Hub to Muswellbrook. 1 x 330 kV double-circuit from West Hub to Muswellbrook. 	950	307 Class 5b (±50%)	39	Medium
<p>Option 1A</p> <ul style="list-style-type: none"> Install a new 330 kV circuit between Liddell and Muswellbrook, Twin Olive conductor. 1 x 330 kV DCST from East Hub to Muswellbrook conductor. 1 x 330 kV DCST from West Hub to Muswellbrook. 	950	283 Class 5b (±50%)	57	Medium
<p>Option 1AB</p> <ul style="list-style-type: none"> Install a new 330 kV circuit between Liddell and Muswellbrook. 1 x 330 kV DCST from East Muswellbrook Hub to Muswellbrook. Build 330/132 kV 375 MVA transformer at West Muswellbrook Hub. 1 x 132 kV DCST from West Muswellbrook Hub to Muswellbrook. 	850	274 Class 5b (±50%)	57	Medium
<p>Option 1B</p> <ul style="list-style-type: none"> Rebuild the existing Line 83 Liddell–Muswellbrook as 330 kV double-circuit line. 1 x 330 kV DCST from East Muswellbrook Hub to Muswellbrook. Build 330/132 kV 375 MVA transformer at West Muswellbrook Hub. 1 x 132 kV DCST from West Muswellbrook Hub to Muswellbrook. 	850	298 Class 5b (±50%)	39	Medium
<p>Option 2:</p> <ul style="list-style-type: none"> New 330 kV Singleton switching station and cuts into line 82 Liddell–Tomago. 	500	59 Class 5b (±50%)	-	Short
<p>Option 2A</p> <ul style="list-style-type: none"> New 330/132 kV 375 MVA Singleton two transformer substation and cuts into line 82 Liddell–Tomago and connected to Ausgrid’s Singleton 132 kV substation switching station. 	375	106 Class 5b (±50%)	-	Medium

Adjustment factors and risk		
Option	Adjustment factors applied	Known and unknown risks applied
Option 1	<ul style="list-style-type: none"> Land Use: Grazing Jurisdiction: NSW – Central Project network element size: 10 to 100 km / # of total Bays 11 – 15 Location (regional/distance factors): Remote Delivery timetable: Long 	Known Risks: <ul style="list-style-type: none"> Compulsory acquisition: High/BAU Environmental offset risks: High Market activity: Tight Others: BAU Unknown risks: Class 5b
Option 1A	As per Option 1 except: Project network element size: 10 to 100 km/# of total Bays 6 – 10	As per Option 1 above
Option 1AB	As per Option 1	As per Option 1 above
Option 1B	As per Option 1	As per Option 1 above
Option 2	<ul style="list-style-type: none"> Land Use: Grazing Jurisdiction: NSW – Central Project network element size: # of total Bays 1 – 5/Below 1 km Location (regional/distance factors): Remote Delivery timetable: Long 	Known Risks: <ul style="list-style-type: none"> Compulsory acquisition: High/BAU Environmental offset risks: High Market activity: Tight Others: BAU Unknown risks: Class 5b
Option 2A	As per Option 2	As per Option 2 above

4.2.10 Hunter Coast (N10)

Summary				
<p>The Hunter Coast offshore REZ has been identified for the offshore wind resource potential in relatively shallow waters close to shore, with a connection point near to the Sydney load centre⁸⁹.</p>				
Existing network capability				
<p>Newcastle has multiple 330 kV lines already connected and is situated near to the Sydney load centre. Network capacity is shared with local gas generation and coal generation output. The current network transmission limit is approximately 5,500 MW for new generation connections in the Newcastle and Eraring areas. This capacity could also be shared with any new generation connecting in the Hunter Central Coast REZ.</p>				
Augmentation options				
Description	Additional network capacity (MW)	Expected cost (\$ million)	New easement length (km)	Lead time
<p>Option 1:</p> <ul style="list-style-type: none"> CNSW – SNW Option 1 in Section 3.7 (Northern 500 kV loop) or the Hunter Transmission Project would provide additional offshore wind generation from the existing limit of 5,500 MW. 	2,000	Refer to Section 3.7 Option 1	Refer to Section 3.7 Option 1	Medium
Adjustment factors and risk				
Option	Adjustment factors applied	Known and unknown risks applied		
Option 1	See Section 3.7 (Central New South Wales to Sydney, Newcastle and Wollongong)			

⁸⁹ For more information, see Federal Government declaration of the REZ, at <https://www.dcceew.gov.au/energy/renewable/establishing-offshore-infrastructure/hunter#:~:text=on%20Wind%20Turbines-.Area%20in%20the%20Pacific%20Ocean%20off%20the%20Hunter%20declared%20suitable,development%20on%2012%20July%202023>.



4.2.11 Illawarra Coast (N11)

Summary				
<p>To be able to facilitate large amounts of offshore wind connecting in this part of the 330 kV network, it is anticipated that expansion will be required to connect to the 500 kV backbone.</p> <p>The REZ has been declared with 1,000 MW of intended network capacity and EnergyCo has been appointed the Infrastructure Planner enabled by the <i>Electricity Infrastructure Investment Act 2020</i>.</p>				
Existing network capability				
<p>Dapto has multiple 330 kV lines already connected and is situated near to the Sydney load centre. Network capacity is shared with local gas generation and hydro generation output. The current network transfer capacity is approximately 1,000 MW. This capacity could also be shared with any new generation connecting in the Illawarra REZ.</p>				
Augmentation options				
Description	Additional network capacity (MW)	Expected cost (\$ million)	New easement length (km)	Lead time
<p>Option 1:</p> <ul style="list-style-type: none"> 500 kV double-circuit line from Dapto – Bannaby. Two 500/330 kV 1,500 MVA transformers at Dapto. <p>(Pre-requisite: CNSW – SNW Option 2)</p>	2,000	814 Class 5b (±50%)	100	Long
Adjustment factors and risk				
Option	Adjustment factors applied	Known and unknown risks applied		
Option 1	<ul style="list-style-type: none"> Land Use: Developed area/Scrub Jurisdiction: NSW – Central Project network element size: # of total Bays 11 – 15/100 to 200 km Location (regional/distance factors): Regional/Urban Delivery timetable: Long 	<p>Known risks:</p> <ul style="list-style-type: none"> Compulsory acquisition: High/BAU Outage restrictions: High/BAU Project complexity: Partly complex Environmental offset risks: High Others: BAU <p>Unknown risks: Class 5b</p>		

4.2.12 Illawarra (N12)

Summary				
<p>The Illawarra REZ was formally declared by the Minister for Energy in NSW on 27 February 2023⁹⁰. Community consultation has been initiated by EnergyCo, following an earlier Registration of Interest that highlighted potential for wind (onshore and offshore), solar, energy storage, pumped hydro, hydrogen production, and green steel manufacturing.</p>				
Existing network capability				
<p>Dapto has multiple 330 kV lines already connected and is situated near to the Sydney load centre. Network capacity is shared with local gas generation and hydro generation output. The intended network capacity for this REZ is approximately 1,000 MW.</p>				
Augmentation options ⁹¹				
Description	Additional network capacity (MW)	Expected cost (\$ million)	New easement length (km)	Lead time
<p>Option 1:</p> <ul style="list-style-type: none"> 500 kV double-circuit line from Dapto – Bannaby. Two 500/330 kV 1,500 MVA transformers at Dapto. <p>(Pre-requisite: CNSW – SNW Option 2)</p>	2,000	814 Class 5b (±50%)	100	Long
Adjustment factors and risk				
Option	Adjustment factors applied	Known and unknown risks applied		
Option 1	<ul style="list-style-type: none"> Land Use: Developed area/Scrub Jurisdiction: NSW – Central Project network element size: # of total Bays 11 – 15/100 to 200 km Location (regional/distance factors): Regional/Urban Delivery timetable: Long 	<p>Known risks:</p> <ul style="list-style-type: none"> Compulsory acquisition: High/BAU Outage restrictions: High/BAU Project complexity: Partly complex Environmental offset risks: High Others: BAU Unknown risks: Class 5b 		

⁹⁰ EnergyCo, Illawarra Renewable Energy Zone, at <https://www.energyco.nsw.gov.au/ilw-rez>.

⁹¹ EnergyCo does not currently have network options for this REZ in its Network Infrastructure Strategy document.

4.3 Queensland

AEMO will engage with the Queensland Government as the Queensland REZ Roadmap is developed. The draft roadmap was released in July 2023.

4.3.1 Far North Queensland (Q1)

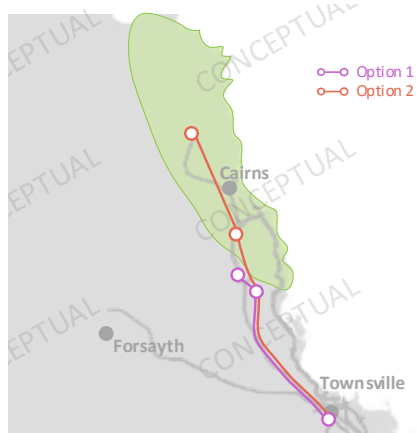
Summary				
<p>The Far North Queensland (FNQ) REZ is at the most northerly section of Powerlink’s network. It has good wind and moderate solar resources and has existing hydroelectric power stations. Two options are proposed that progressively increase network capacity and allow for upgrades based on where generation develops.</p>				
Existing network capability				
<p>The current total REZ transmission limit for existing and new VRE before any network upgrade in Far North Queensland is approximately 750 MW for peak demand, summer typical and winter reference conditions.</p>				
Augmentation options				
Description	Additional network capacity (MW)	Expected cost (\$ million)	New easement length (km)	Lead time
<p>Option 1:</p> <ul style="list-style-type: none"> Establish a new 275 kV substation north of Millstream. Build a 275 kV double-circuit line from Chalumbin to Millstream. Rebuild the double-circuit Chalumbin–Ross 275 kV line at a higher capacity (possibly timed with asset replacement). Build additional Chalumbin–Ross 275 kV double-circuit tower but switch as a single-circuit line (energise second line as generation develops). 	1,290	1,836 Class 5b (±50%)	275	Long
<p>Option 2:</p> <ul style="list-style-type: none"> Establish a new 275 kV substation in the Lakeland area. Build a double-circuit 275 kV line from Walkamin to the new substation near Lakeland. Build a new 275 kV Chalumbin–Walkamin single-circuit line. Rebuild the double-circuit Chalumbin–Ross 275 kV line at a higher capacity (possibly timed with asset replacement). Build additional Chalumbin–Ross 275 kV double-circuit tower but switch as a single-circuit line (energise second line as generation develops). 	1,290	2,780 Class 5b (±50%)	535	Long
Adjustment factors and risk				
Option	Adjustment factors applied	Known and unknown risks applied		
Option 1	<ul style="list-style-type: none"> Land Use: Scrub Jurisdiction: QLD – North Project network element size: Above 200 km/# of total Bays 1 – 5 Location (regional/distance factors): Regional Delivery timetable: Long 	<p>Known Risks:</p> <ul style="list-style-type: none"> Compulsory acquisition: Low/BAU/High Cultural heritage: Low/BAU/High Geotechnical findings: Low/BAU Others: BAU <p>Unknown risks: Class 5b</p>		
Option 2	<ul style="list-style-type: none"> Land Use: Scrub Jurisdiction: QLD – North 	As per option 1		



	<ul style="list-style-type: none">• Project network element size: Above 200 km/# of total Bays 1 – 5• Location (regional/distance factors): Remote/Regional Delivery timetable: Long	
--	---	--

4.3.2 North Queensland Clean Energy Hub (Q2)

Summary				
<p>The Clean Energy Hub REZ is at the north-western section of Powerlink’s network, and has excellent wind and solar resources.</p> <p>The Queensland Government has announced that it will deliver the 1,100 km CopperString 2032 project. CopperString 2032 will connect the North-West Minerals Province of Queensland to the National Electricity Market via Woodstock near Townsville. The project scope includes 500 kV transmission capacity between Townsville and Hughenden to unlock the renewable energy potential of the region.</p> <p>AEMO is now considering the CopperString 2032 project as an Anticipated Project after outcomes from joint planning with Powerlink and the Queensland Government.</p>				
Existing network capability				
<p>The project to establish CopperString 2032 is considered anticipated. As such the existing network capability is assumed to be approximately 2,200 MW, incorporating the CopperString 2032 project (1,500 MW) as well as existing network capability (700 MW) for peak demand, summer typical and winter reference conditions. For the 2024 ISP, only the 500 kV section of CopperString 2032 is modelled.</p> <p>The existing network at the North-West Mineral Province is islanded from the NEM. The NEM only extends as far west as Julia Creek and is mainly energised at 66 kV in that area. The existing network for this REZ was designed to support North-West Queensland load, rather than building for future generation projects. The REZ can potentially support much more generation.</p>				
Augmentation options				
Description	Additional network capacity (MW)	Expected cost (\$ million)	New easement length (km)	Lead time
<p>CopperString 2032:</p> <ul style="list-style-type: none"> Establish a new 500 kV substation south of Townsville (NQ 500 kV Substation) Install 2x500/275 kV, 1500 MVA transformers at NQ 500kV substation Establish a new NQ 275 kV substation Cut-in the Strathmore to Ross 275kV DCST and SCST lines to the NQ 275kV Substation. Establish a new 500 kV substation at Hughenden with associated switchgear and bays. Establish a new 500kV substation (mid-point between NQ 500 kV and Hughenden substations) with associated switchgear and bays. A new 500 kV transmission line from south of Townsville to Hughenden A new 330 kV transmission line from Hughenden to Cloncurry A new 220 kV transmission line from Cloncurry to Mount Isa Up to six new substation sites 	1,500 nominal 2,300 if NQ-CQ Option 2 is selected.	This project is considered to be anticipated and so is not included as an option here. The scope of the project is listed here for context only.		
<p>Option 1:</p> <ul style="list-style-type: none"> Establish a 275 kV yard at Kidston substation near Forsayth. Build a 275 kV double-circuit line from Kidston to Guybal Munjan substation (energise only a single line until generation in the REZ develops). 	500	651 Class 5a (±30%)	190	Medium
<p>Option 2:</p> <ul style="list-style-type: none"> Energise the second circuit on the line established in Option 1. Additional reactors if required. <p><i>Pre-requisite: Q2 Option 1</i></p>	1,000	Nil	-	Medium
Adjustment factors and risk				
Option	Adjustment factors applied	Known and unknown risks applied		

Option 1	<ul style="list-style-type: none"> • Land Use: Desert/Scrub • Jurisdiction: QLD – North • Project network element size: 100 to 200 km/# of total Bays 6 – 10 • Location (regional/distance factors): Remote • Delivery timetable: Long 	<p>Known risks: BAU other than:</p> <ul style="list-style-type: none"> • Market Activity: Tight <p>Unknown risks: 5a</p>
Option 3	<ul style="list-style-type: none"> • Land Use: Grazing/Desert • Jurisdiction: QLD – North • Project network element size: Above 200 km/# of total Bays 6 – 10 • Location (regional/distance factors): Remote/Regional • Delivery timetable: Long 	<ul style="list-style-type: none"> • Known risks: BAU • Unknown risks: Class 5b

4.3.3 Northern Queensland (Q3)

Summary				
<p>The North Queensland REZ encompasses Townsville and the surrounding area. It has good quality solar and wind resources and is situated close to the high-capacity 275 kV network. There are already a number of existing large-scale solar generation projects operational within this REZ.</p>				
Existing network capability				
<p>Existing network capacity can allow for up to approximately 1,200 MW of new generator connections, shared between Q1, Q2 and Q3 as given by group constraint NQ2.</p>				
Augmentation options				
Description	Additional network capacity (MW)	Expected cost (\$ million)	New easement length (km)	Lead time
Option 1 and Option 2: see Section 3.2 (Central Queensland and Northern Queensland flow path augmentations)				
Adjustment factors and risk				
Option	Adjustment factors applied	Known and unknown risks applied		
Option 1 and Option 2: see Section 3.2 (Central Queensland to Northern Queensland flow path augmentations)				

4.3.4 Isaac (Q4)

Summary				
<p>The Isaac REZ has good wind and solar resources covering Collinsville and Mackay, and has a number of large-scale solar generation projects already in operation. There are numerous potential pumped hydro locations to the north east and south east of Nebo. This REZ has a good diversity of resources – wind, solar and storage. Locating storage in this zone could maximise transmission utilisation towards Brisbane.</p> <p>The Queensland government has announced that, subject to final investment decisions, it will build a 5,000 MW/24-hour Pioneer-Burdekin pumped hydro energy storage project in this area near the Burdekin shire, as part of the QEJP.</p>				
Existing network capability				
<p>The Isaac REZ forms part of the NQ transmission backbone from Nebo to Strathmore. Due to the existing high voltage infrastructure there are no augmentation options specifically for this REZ. The associated augmentations are the NQ2 group constraint and CQ-NQ flow path augmentations that facilitate power from Q1 to Q5 to be transmitted south to the load centres (see Section 4.3.10).</p> <p>The network has the ability to support up to a total of 2,500 MW of generation in Summer peak and Summer typical conditions and 2,750 MW for Winter reference conditions across the REZs in northern Queensland.</p>				
Augmentation options				
Description	Additional network capacity (MW)	Expected cost (\$ million)	New easement length (km)	Lead time
See Section 4.3.10 (NQ2 group constraint augmentations)				
Adjustment factors and risk				
Option	Adjustment factors applied	Known and unknown risks applied		
See Section 4.3.10 (NQ2 group constraint augmentations)				

4.3.5 Barcaldine (Q5)

Summary				
<p>This REZ has excellent solar resources and moderate wind resources but is located a long way from the Queensland transmission backbone. Barcaldine REZ has not been identified as having significant potential pumped hydro capability.</p>				
Existing network capability				
<p>The current total REZ transmission limit for existing and new VRE before any network upgrade in Barcaldine is approximately 85 MW for peak demand, summer typical and winter reference conditions.</p>				
Augmentation options				
Description	Additional network capacity (MW)	Expected cost (\$ million)	New easement length (km)	Lead time
<p>Option 1:</p> <ul style="list-style-type: none"> Establish a 275 kV substation in the Barcaldine region. Build a 340 km 275 kV double-circuit line from Lilyvale to Barcaldine (energise only a single line until generation in the REZ develops). 	500	1,068 Class 5b (±50%)	340	Long
<p>Option 2:</p> <ul style="list-style-type: none"> Energise the second circuit on the line established in Option 1. Additional substation bays and reactors if required. <p><i>Pre-requisite: Q5 Option 1</i></p>	850	Nil	-	Medium
Adjustment factors and risk				
Option	Adjustment factors applied	Known and unknown risks applied		
Option 1	<ul style="list-style-type: none"> Land Use: Desert Jurisdiction: QLD – Central Project network element size: # of total Bays 6 – 10/Above 200 km Location (regional/distance factors): Remote Delivery timetable: Long 	<p>Known risks:</p> <ul style="list-style-type: none"> Compulsory acquisition: BAU/Low Cultural heritage: BAU/Low Others: BAU <p>Unknown risks: Class 5b</p>		
Option 2	As per option 1	As per option 1		

4.3.6 Fitzroy (Q6)

Summary				
<p>The Fitzroy REZ is in Central Queensland and covers a strong part of the network where Gladstone and Callide generators are connected. This REZ has good solar and wind resources. It is the focal point for power transfer from Central and Northern Queensland to the load centre in Southern Queensland.</p>				
Existing network capability				
<p>This Fitzroy network internal capability is limited by the thermal capacity of the Calvale–Wurdong, Bouldercombe–Calliope River, Bouldercombe–Raglan, Larcom Creek–Calliope River or Calliope River–Wurdong 275 kV circuits. Network capability to export electricity to southern Queensland is shared between VRE generation within Fitzroy REZ and other generation within northern and central Queensland.</p> <p>Due to the existing high voltage infrastructure, there are no augmentation options specifically for this REZ. The associated augmentations are the Central Queensland to Gladstone Grid flow path augmentations (see Section 3.3)</p>				
Augmentation options				
Description	Additional network capacity (MW)	Expected cost (\$ million)	New easement length (km)	Lead time
See Section 3.3 (Central Queensland to Gladstone Grid flow path augmentations)				
Adjustment factors and risk				
Option	Adjustment factors applied	Known and unknown risks applied		
See Section 3.3 (Central Queensland to Gladstone Grid flow path augmentations)				

4.3.7 Wide Bay (Q7)

Summary				
<p>The Wide Bay area has moderate solar resources and already has a number of large solar PV generators operational within the REZ. There is difficulty acquiring easements in this residential area, however Powerlink do have a double width easement most of the way from Woolooga to Palmwoods and to South Pine, so double-circuits would be built in-situ next to the existing circuits, then the single-circuit would be de-energised. This may help reduce those challenges around obtaining easements as well as obtaining outages of critical circuits, should the generation interest exceed the current network capacity.</p>				
Existing network capability				
<p>The existing network facilitates power transfer from Central Queensland to the load centre in Brisbane. This is a 275 kV transmission backbone and currently supports up to approximately 1,400 MW of power flow from CQ into Brisbane during summer peak, summer typical and winter reference conditions. This means the maximum VRE output in the REZ is highly dependent on CQ-SQ flow.</p>				
Augmentation options				
Description	Additional network capacity (MW)	Expected cost (\$ million)	New easement length (km)	Lead time
See Section 4.3.10 (SQ1 group constraint augmentations)				
Adjustment factors and risk				
Option	Adjustment factors applied	Known and unknown risks applied		
See Section 4.3.10 (SQ1 group constraint augmentations)				

4.3.8 Darling Downs (Q8)

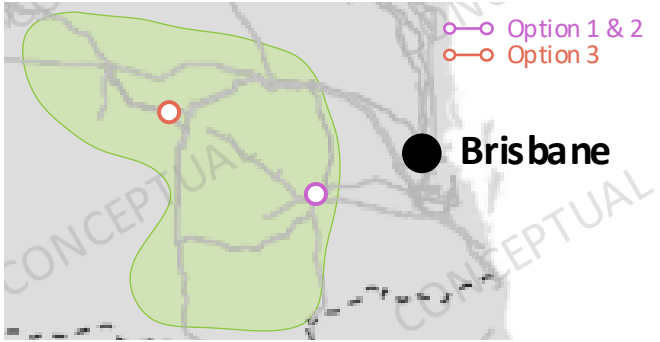
Summary				
<p>The Darling Downs REZ extends from the border of NSW around Dumaresq, up to Columboola within the Surat region of Queensland, and has good solar and wind resources. A number of large solar and wind projects are already connected within the zone.</p>		 <p>The map shows the Darling Downs Renewable Energy Zone (REZ) in Queensland, Australia, highlighted in green. It is located west of Brisbane. Two options are marked: Option 1 & 2 (purple circle) and Option 3 (red circle). Brisbane is marked with a black dot. The map includes a 'CONCEPTUAL' watermark.</p>		
Existing network capability				
<p>The Darling Downs REZ has high network capacity and is near QNI and Brisbane. Furthermore, the ultimate retirement of generation within this REZ will allow for increased VRE connections.</p> <p>The existing network facilitates power transfer from south west Queensland to the load centre in Brisbane. This transmission can support up to approximately 5,300 MW of generation into Brisbane during summer peak, summer typical and winter reference conditions. However this capability is significantly reduced depending on the output of existing coal and gas generation in the REZ, the flow of power from NSW, and the flow of power from central Queensland. To capture these sensitivities the augmentations are associated with the SWQLD1 transmission limit constraint that facilitates power flow to load centres in south east Queensland.</p>				
Augmentation options				
Description	Additional network capacity (MW)	Expected cost (\$ million)	New easement length (km)	Lead time
See Section 4.3.10 (SWQLD1 transmission limit constraint augmentations)				
Adjustment factors and risk				
Option	Adjustment factors applied	Known and unknown risks applied		
See Section 4.3.10 (SWQLD1 transmission limit constraint augmentations)				

4.3.9 Banana (Q9)

Summary				
<p>The Banana REZ is located roughly 200 km south-west of Gladstone and lies north of the CQ-SQ flow path (see Section 3.4). It has moderate wind and excellent solar resources. There are currently no generators and very little high voltage network in this area. The first two options are proposals that transport the power to the Gladstone region. Substation location both within the Banana REZ and the connection point within the Gladstone section will be based on where generation and load develop.</p> <p>AEMO understands from the Queensland Government and from Powerlink that transmission augmentation projects for the Banana REZ are likely to be delivered as a dedicated asset of some kind. This may need to be treated similar to a generation connection asset in the ISP model, rather than like a network augmentation option.</p>				
Existing network capability				
<p>There is currently very little high voltage network in the area. There is some 132 kV network on the edge of the REZ, supporting the townships of Moura and Biloela. There is very little spare capacity within the network.</p>				
Augmentation options ⁹²				
Description	Additional network capacity (MW)	Expected cost (\$ million)	New easement length (km)	Lead time
<p>Option 1:</p> <ul style="list-style-type: none"> Establish a new 500 kV substation within the Banana REZ. 200 km double-circuit 500 kV line from the Banana REZ to CQ substation associated with CQ-SQ Option 5. Additional 500/275 kV 1,500 MVA transformer at the CQ substation. Switchgear at CQ substation. <p><i>Pre-requisite: CQ-SQ Option 5</i></p>	3,000	1,078 Class 5b (±50%)	200	Long
<p>Option 2:</p> <ul style="list-style-type: none"> Establish a new 275 kV substation within the Banana REZ. 100 km high capacity double-circuit 275 kV line from Banana REZ to Calvale Substation. Associated switchgear. Limit extension special protection scheme (similar to a virtual transmission line). Cost of non-network service agreement excluded. <p><i>Pre-requisite: Central Queensland to Gladstone Grid Option 1</i></p>	1,800	414 ⁹¹ Class 5b (±50%)	200	Medium
<p>Option 3:</p> <ul style="list-style-type: none"> Establish a new 275 kV substation within the Banana REZ. 195 km double-circuit 275 kV line from Banana REZ to Wandoan South. Switchgear at Wandoan South. 	1,000	663 ⁹¹ Class 5b (±50%)	195	Medium
Adjustment factors and risk				
Option	Adjustment factors applied	Known and unknown risks applied		
Option 1	<ul style="list-style-type: none"> Land Use: Grazing Jurisdiction: QLD – Central 	<ul style="list-style-type: none"> Known Risks: BAU 		

⁹² Banana REZ expansion options are understood to be likely to be dedicated network assets which connect VRE in the region to either CQ or NQ. As such, AEMO is likely to model these options similar to generator connection assets rather than REZ network expansions in the ISP model.

	<ul style="list-style-type: none"> Project network element size: Above 200 km/# of total Bays 6 – 10 Location (regional/distance factors): Regional Delivery timetable: Optimum 	<ul style="list-style-type: none"> Unknown Risk: Class 5b
Option 2	<ul style="list-style-type: none"> Land Use: Grazing Jurisdiction: QLD – Central Project network element size: Above 200 km/# of total Bays 1 – 5 Location (regional/distance factors): Regional Delivery timetable: Optimum 	<p>Known Risks:</p> <ul style="list-style-type: none"> Market Activity: Tight Others: BAU <p>Unknown Risk: Class 5b</p>
Option 3	<p>As per option 2, except:</p> <ul style="list-style-type: none"> Project network element size: 100 km to 200 km 	As per option 2

4.3.10 Queensland group constraints and transmission limit constraints

NQ2 Group constraint

Summary				
<p>Upgrade options associated with the Group Constraint NQ2 may be built to improve the generation capacity in Northern Queensland, Q1 to Q5. These augmentations will facilitate transmission of this generation to load centres in the south.</p> <p>The Queensland Government has announced that, subject to final investment decisions, it will build a 5,000 MW/24-hour Pioneer-Burdekin pumped hydro energy storage project in this area near the Burdekin shire, as part of the Queensland SuperGrid.</p>				
Existing network capability				
<p>The current network was designed to facilitate the transmission of power from Central Queensland to support the load in Northern Queensland. Thus, its capacity was designed around North Queensland load, rather than building for future generation projects.</p> <p>The network has the ability to support up to 2,500 MW of generation during summer peak and summer typical conditions and 2,750 MW during winter reference conditions.</p>				
Augmentation options				
Description	Additional network capacity (MW)	Expected cost (\$ million)	New easement length (km)	Lead time
<p>Option 1:</p> <ul style="list-style-type: none"> Construct additional 275 kV circuit from Bouldercombe – Stanwell. String and energise the second Broadsound-Stanwell 275 kV additional circuit (on existing DCST). 	400	173 Class 5b (±50%)	146	Medium
<p>Option 2:</p> <ul style="list-style-type: none"> Additional 275 kV double-circuit lines between Central and North Queensland. 	1,400	1,008 Class 5b (±50%)	295	Medium
Adjustment factors and risk				
Option	Adjustment factors applied	Known and unknown risks applied		
Option 1	<ul style="list-style-type: none"> Land Use: Scrub Jurisdiction: QLD – Central Project network element size: # of total Bays 1 – 5/100 to 200 km Location (regional/distance factors): Regional Delivery timetable: Long 	<ul style="list-style-type: none"> Known risks: Compulsory acquisition: BAU/Low Cultural heritage: BAU/Low Geotechnical findings: BAU/Low Market Activity: Tight Others: BAU Unknown risks: Class 5b 		
Option 2	As per option 1	As per option 1		

SQ1 Group constraint

Summary				
<p>Upgrade options associated with the Group Constraint SQ1 may be built to improve the generation capacity in Central Queensland and Q7. These augmentations will facilitate transmission of this generation to load centres in the locality of Brisbane.</p> <p>The Queensland Government has announced that, subject to final investment decisions, it will build a 2,000 MW/24-hour Borumba pumped hydro energy storage project in southern Queensland, as part of the Queensland SuperGrid.</p> <p>This project could affect future augmentations and capacity limits associated to this group constraint, and as such will also be included as part of this constraint in the ISP modelling process.</p>				
Existing network capability				
<p>This is a 275 kV transmission backbone and currently supports up to approximately 1,400 MW of power flow from CQ into Brisbane during summer peak, summer typical and winter reference conditions. This means the maximum VRE output in the REZ is highly dependent on CQ-SQ flow.</p>				
Augmentation options				
Description	Additional network capacity (MW)	Expected cost (\$ million)	New easement length (km)	Lead time
<p>Option 1:</p> <ul style="list-style-type: none"> Rebuild Woolooga – Palmwood – South Pine 275 kV single-circuit line as a high-capacity double-circuit line. 100 MVAR reactor for voltage control. 	1,100	536 ⁹³ Class 5b (±50%)	-	Long
<p>Option 2:</p> <ul style="list-style-type: none"> Rebuild Woolooga – South Pine 275 kV single-circuit line as a high-capacity double-circuit line. 100 MVAR reactor for voltage control. 	1,100	583 ⁹⁴ Class 5b (±50%)	-	Long
<p>Option 3:</p> <ul style="list-style-type: none"> Prerequisite is CQ-SQ Option 5. New 500 kV works at Borumba substation. Cut-in Halys-Woolooga West 500 kV line at Borumba. 	1,700 ⁹⁵	111 Class 5b (±50%)	-	Long
Adjustment factors and risk				
Option	Adjustment factors applied	Known and unknown risks applied		
Option 1	<ul style="list-style-type: none"> Land Use: Grazing Jurisdiction: QLD – South Project network element size: 100 to 200 km/# of total Bays 1 – 5 	<p>Known Risks:</p> <ul style="list-style-type: none"> Compulsory acquisition : Low Cultural heritage : Low 		

⁹³ This cost estimate assumes zero costs for acquiring property and for environmental offsets because it is a line rebuild project. As stated in Q7, the existing easement is double width and so the new double-circuit could be built in situ next to the existing circuit to limit outage constraints and market impact. As a result, the attached Transmission Cost Database cost estimate output file for this option will include a larger cost estimate than what is reported here.

⁹⁴ Due to this cost being a line rebuild, the easement is already partially acquired by Powerlink. Therefore, the cost of acquiring property and environment offset costs has been reduced by 30%. However, this is only a single width easement, so the existing line would have to be removed before a new double-circuit could be built. This work would incur significant market impact.

⁹⁵ This expansion capacity represents the synthesis of studies across a range of different network conditions to determine the additional hosting capability of the REZ with Borumba Pumped Hydro Energy Storage (PHES) already added. This number does not represent a hard 1,700 MW limit on Borumba output.

	<ul style="list-style-type: none"> • Location (regional/distance factors): Regional • Delivery timetable: Long/Optimum 	<ul style="list-style-type: none"> • Geotechnical findings : Low • Others: BAU • Unknown risks: Class 5b
Option 2	As per option 1	As per option 1, except: <ul style="list-style-type: none"> • Known risks: outage restrictions High
Option 3	<ul style="list-style-type: none"> • Land Use: Developed area/Grazing • Jurisdiction: QLD – South • Project network element size: # of total Bays 1 – 5/Below 1 km • Location (regional/distance factors): Regional/Urban • Delivery timetable: Tight/Optimum 	<p>Known Risks: BAU</p> <p>Unknown Risks: Class 5b</p>

SWQLD1 transmission limit constraint

Summary				
<p>Upgrade options associated with the transmission limit constraint SWQLD1 may be built to improve the generation capacity in south west Queensland. These augmentations will facilitate transmission of this generation to load centres in the locality of Brisbane.</p>				
Existing network capability				
<p>The existing network facilitates power transfer from south west Queensland to the load centre in Brisbane. This transmission can support up to approximately 5,300 MW of generation into Brisbane during summer peak, summer typical and winter reference conditions. However this capability is significantly reduced depending on the output of existing coal and gas generation in the REZ, the flow of power from New South Wales, and the flow of power from central Queensland.</p>				
Augmentation options				
Description	Additional network capacity (MW)	Expected cost (\$ million)	New easement length (km)	Lead time
<p>Option 1:</p> <ul style="list-style-type: none"> Replace existing 1,300 MVA 330/275 kV transformer at Middle Ridge with 1,500 MVA 330/275 kV transformer. <p><i>Provided by Powerlink – see Section 1.2.</i></p>	500	28 ⁹⁶ Class 5 (±50%)	-	Short
<p>Option 2:</p> <ul style="list-style-type: none"> Implement a limit extension special protection scheme – run-back of generation in SWQ with 300 MW BESS response in SEQ (similar to a virtual transmission line)⁹⁷. 	330	Non-network projects are not estimated as part of the Transmission Expansion Options Report.		
<p>Option 3:</p> <ul style="list-style-type: none"> Prerequisite is NNSW-SQ Option 5 and CQ-SQ Option 5 and SQ1 option 3. New 2 x 500/275 kV 1,500 MVA transformers at Western Downs with associated switchgear and bays. Cut-in 500 kV DCST lines from Halys to NNSW and associated switchgear and bays. 	1,500	184 Class 5b (±50%)	-	Long
Adjustment factors and risk				
Option	Adjustment factors applied	Known and unknown risks applied		
Option 1	<ul style="list-style-type: none"> Land Use: Grazing Jurisdiction: QLD – South Project network element size: # of total Bays 1 – 5 Location (regional/distance factors): Regional Delivery timetable: Long 	<p>Known Risks:</p> <ul style="list-style-type: none"> Compulsory acquisition: Low Cultural heritage: Low Geotechnical findings: Low Outage restrictions: High Market Activity: Tight Others: BAU <p>Unknown risks: Class 5b</p>		
Option 2	Non-network projects are not estimated as part of the Transmission Expansion Options Report.			
Option 3	<ul style="list-style-type: none"> Land Use: Developed area/Grazing Jurisdiction: QLD – South 	<p>Known Risks:</p> <ul style="list-style-type: none"> Others: BAU <p>Unknown Risks: Class 5b</p>		

⁹⁶ See Preparatory Activities page, at <https://aemo.com.au/consultations/current-and-closed-consultations/2023-transmission-expansion-options-report-consultation>.

⁹⁷ In addition to this scheme, Powerlink’s preparatory activities note a special protection system splitting scheme. This has not been included as it is an operational scheme that may later be considered as part of a RIT-T.



	<ul style="list-style-type: none">• Project network element size: # of total Bays 6 – 10/Below 1 km• Location (regional/distance factors): Regional/Urban• Delivery timetable: Tight/Optimum	
--	--	--



4.4 South Australia

4.4.1 South East SA (S1)

Summary				
<p>The South East SA REZ lies on the major 275 kV route of the South Australia – Victoria Heywood interconnector. The REZ has moderate to good quality wind resources, as evidenced by the high proportion of wind generation (over 300 MW) in or near the South East border with Victoria.</p>				
Existing network capability				
<p>The existing network capacity of this REZ is modelled as part of SESA-CSA sub-regional maximum transfer capability of 650 MW. Further network augmentation is required to allow additional generation to be built. Network augmentations would be smaller if generation is located relatively close to Adelaide, and larger if located further south towards Mount Gambier.</p> <p>Other than the preparatory activity upgrade, there are no augmentation options specifically for this REZ. The associated augmentations are the VIC-SESA and SESA-CSA flow path augmentations (see Sections 3.11 and 3.12).</p> <p>The preparatory activities looks to address the existing limit of overloading of the Taillem Bend–Mobilong 132 kV line on trip of one Taillem Bend–Tungkillo 275 kV line, and is modelled by a separate REZ Transmission limit S1-TBMO.</p>				
Augmentation options				
Description	Additional network capacity (MW)	Expected cost (\$ million)	New easement length (km)	Lead time
<p>Option 1 (part of preparatory activities):</p> <ul style="list-style-type: none"> String vacant circuit on the 275 kV Tungkillo – Taillem Bend line. <p><i>Provided by ElectraNet – see Section 1.2.</i></p>	120	34 Class 5b (± 50%)	-	Short
See Sections 3.11 and 3.12 (VIC-SESA and SESA-CSA augmentations)				
Adjustment factors and risk				
Option	Adjustment factors applied	Known and unknown risks applied		
See Sections 3.11 and 3.12 (VIC-SESA and SESA-CSA augmentations)				

4.4.2 Riverland (S2)

Summary				
The Riverland REZ is on the South Australian side of the proposed Project EnergyConnect route. It has good solar quality resources.				
Existing network capability				
There is minimal existing renewable generation in the zone. Prior to Project EnergyConnect, approximately 130 MW can be connected in this REZ for all three operating conditions (peak demand, summer typical and winter reference). Once Project EnergyConnect is commissioned, approximately 800 MW can be accommodated.				
Augmentation options				
Description	Additional network capacity (MW)	Expected cost (\$ million)	New easement length (km)	Lead time
Option 1 (Post PEC) ⁹⁸ : <ul style="list-style-type: none"> Co-ordinate new connections through turn in of Bunday – Buronga 330 kV No. 1 and No. 2 lines into a new substation at Riverland. 	700	100 Class 5a (± 30%)	-	Short
Adjustment factors and risk				
Option	Adjustment factors applied	Known and unknown risks applied		
Option 1	<ul style="list-style-type: none"> Land Use: Grazing Jurisdiction: SA – Adelaide and Fleurieu Project network element size: # of total Bays 6 – 10/Below 1 km Location (regional/distance factors): Remote Delivery timetable: Long 	Known risks: BAU except: <ul style="list-style-type: none"> Market Activity: Tight Unknown risks: Class 5a		

⁹⁸ Additional REZ capacity will be reliant on additional circuits being connected to Bunday after Project EnergyConnect is complete.

4.4.3 Mid-North SA (S3)

Summary				
<p>The Mid-North SA REZ has moderate quality wind and solar resources. There are several major wind farms in service in this REZ, totalling > 950 MW installed capacity.</p> <p>Four 275 kV parallel circuits provide the bulk transmission along the corridor from Davenport to near Adelaide (Para) which traverse this REZ. This transmission corridor forms the backbone for exporting power from REZs north and west of this REZ in South Australia.</p>				
Existing network capability				
<p>The capability of this zone to accommodate new generation is subject to the MN1 mid-north group constraint⁹⁹.</p>				
Augmentation options				
Description	Additional network capacity (MW)	Expected cost (\$ million)	New easement length (km)	Lead time
See Section 4.4.11 (SA Group Constraints, MN1)				
Adjustment factors and risk				
Option	Adjustment factors applied	Known and unknown risks applied		
See Section 4.4.11 (SA Group Constraints, MN1)				

⁹⁹ Additional augmentation is required in Mid-North when the combination of generation in S3, S4, S5, S6, S7, S8, S9 >2,400 MW.

4.4.4 Yorke Peninsula (S4)

Summary				
<p>The Yorke Peninsula REZ has good quality wind resources. A single 132 kV line extends from Hummocks to Wattle Point (towards the end of Yorke Peninsula).</p>				
Existing network capability				
<p>The existing 132 kV network has 100 MW of additional network capacity for all three operating conditions (peak demand, summer typical and Winter reference). Transmission augmentation is required to connect any significant additional generation in this REZ.</p> <p>The capability of this zone to accommodate new generation is subject to the MN1 mid-north group constraint¹⁰⁰.</p>				
Augmentation options				
Description	Additional network capacity (MW)	Expected cost (\$ million)	New easement length (km)	Lead time
<p>Option 1:</p> <ul style="list-style-type: none"> String first circuit of a 275 kV double-circuit line from Blythe West into new Yorke Peninsula substation. <p><i>Pre-requisite: S3 Option 1</i></p>	450	566 Class 5b (± 50%)	162	Medium
<p>Option 2:</p> <ul style="list-style-type: none"> String second circuit of a 275 kV double-circuit line from Blythe West into new Yorke Peninsula substation. Cut in of Templers West into Bunday-Para 275 kV line. <p><i>Pre-requisite: S3 Option 1, Option 1</i></p>	450	156 Class 5b (± 50%)	-	Long
Adjustment factors and risk				
Option	Adjustment factors applied	Known and unknown risks applied		
Option 1	<ul style="list-style-type: none"> Land Use: Grazing Jurisdiction: SA – Adelaide and Fleurieu Project network element size: # of total Bays 6 – 10/100 to 200 km Location (regional/distance factors): Remote/Regional Delivery timetable: Long 	<p>Known risks: BAU except:</p> <ul style="list-style-type: none"> Market Activity: Tight <p>Unknown risks: Class 5b</p>		
Option 2	<p>As per Option 1 except:</p> <p>Project network element size: 100 – 200 km, no. of bays 6-10</p>	<ul style="list-style-type: none"> Known risks: BAU Unknown risks: Class 5b 		

¹⁰⁰ Additional augmentation is required in Mid-North when the combination of generation in S3, S4, S5, S6, S7, S8, S9 >2,400 MW.



4.4.5 Northern SA (S5)

Summary				
<p>The Northern SA REZ has good solar and moderate wind resources. This REZ forms a candidate for a hydrogen electrolyser facility in South Australia.</p>				
Existing network capability				
<p>The capability of this zone to accommodate new generation is subject to the MN1 mid-north and NSA1 northern group constraint¹⁰¹.</p>				
Augmentation options				
Description	Additional network capacity (MW)	Expected cost (\$ million)	New easement length (km)	Lead time
See Section 4.4.11 (SA Group Constraints, NSA1)				
Adjustment factors and risk				
Option	Adjustment factors applied	Known and unknown risks applied		
See Section 4.4.11 (SA Group Constraints, NSA1)				

¹⁰¹ Additional augmentation is required in Mid-North when the combination of generation in S3, S4, S5, S6, S7, S8, S9 >2,400 MW or in Eyre Peninsula when S5, S8, S9 > 500 MW.



4.4.6 Leigh Creek (S6)

Summary				
<p>The Leigh Creek REZ is located between 150 and 350 km north-east of Davenport. It has excellent solar resources and good wind resources.</p> <p>This REZ is currently supplied with a single 132 kV line.</p>				
Existing network capability				
<p>There is no additional network capacity within this REZ.</p> <p>The capability of this zone to accommodate new generation is subject to the MN1 mid-north group constraint¹⁰².</p>				
Augmentation options				
Description	Additional network capacity (MW)	Expected cost (\$ million)	New easement length (km)	Lead time
<p>Option 1:</p> <ul style="list-style-type: none"> Build 275 kV double-circuit line from Davenport to new Leigh Creek substation. 	950	838 Class 5b (± 50%)	235	Short
Adjustment factors and risk				
Option	Adjustment factors applied	Known and unknown risks applied		
Option 1	<ul style="list-style-type: none"> Land Use: Grazing/Scrub Jurisdiction: SA – York and North Project network element size: # of total Bays 11 – 15/Above 200 km Location (regional/distance factors): Remote Delivery timetable: Long 	<p>Known risks: BAU except:</p> <ul style="list-style-type: none"> Market activity: Tight <p>Unknown risks: Class 5b</p>		

¹⁰² Additional augmentation is required in Mid-North when the combination of generation in S3, S4, S5, S6, S7, S8, S9 >2,400 MW.



4.4.7 Roxby Downs (S7)

Summary				
<p>The Roxby Downs REZ is located a few hundred kilometres north-west of Davenport. It has excellent solar resources. The only significant load in the area is the Olympic Dam and Carrapateena mines.</p> <p>This REZ is currently connected with a 132 kV line that provides supply to small loads, and two privately owned 275 kV lines from Davenport that provide supply to large mines in the area.</p>		<p>The map shows a conceptual transmission line (Option 1) in purple, connecting Port Augusta to the Roxby Downs REZ (highlighted in a green circle). The map is overlaid with a 'CONCEPTUAL' watermark.</p>		
Existing network capability				
<p>The existing network capacity of this REZ is 500 MW, although the capability of this zone to accommodate new generation is subject to the MN1 mid-north group constraint¹⁰³.</p>				
Augmentation options				
Description	Additional network capacity (MW)	Expected cost (\$ million)	New easement length (km)	Lead time
<p>Option 1:</p> <ul style="list-style-type: none"> Build 275 kV double-circuit line from Davenport to new Roxby Downs substation. 	950	541 Class 5b (± 50%)	139	Short
Adjustment factors and risk				
Option	Adjustment factors applied	Known and unknown risks applied		
Option 1	<ul style="list-style-type: none"> Land Use: Grazing/Scrub Jurisdiction: SA – Eyre Peninsula Project network element size: # of total Bays 11 – 15/100 to 200 km Location (regional/distance factors): Remote Delivery timetable: Long 	<p>Known risks: BAU except:</p> <ul style="list-style-type: none"> Market Activity: Tight <p>Unknown risks: Class 5b</p>		

¹⁰³ Additional augmentation is required in Mid-North when the combination of generation in S3, S4, S5, S6, S7, S8, S9 >2,400 MW.

4.4.8 Eastern Eyre Peninsula (S8)

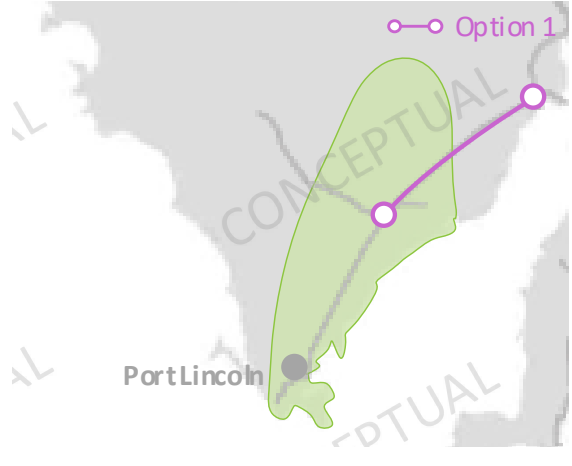
Summary				
<p>The Eastern Eyre Peninsula REZ has moderate to good quality wind resources.</p> <p>The Eyre Peninsula Link was completed in February 2023. It replaced the existing Cultana–Yadnarie–Port Lincoln 132 kV single-circuit line with a new double-circuit 132 kV line. The section between Cultana to Yadnarie will be built to operate at 275 kV, however initially energised at 132 kV.</p>		 <p>The map shows the Eastern Eyre Peninsula region. A green shaded area represents the Renewable Energy Zone (REZ). A grey dot marks the location of Port Lincoln. A purple line with circular endpoints, labeled 'Option 1', indicates the proposed transmission line route starting from the northern part of the REZ and extending towards Port Lincoln.</p>		
Existing network capability				
<p>The existing network capacity of this REZ is 300 MW (subject to the capacity of the 275/132 kV transformers).</p> <p>The capability of this zone to accommodate new generation is subject to the MN1-SA mid-north and NSA1 northern group constraint¹⁰⁴.</p>				
Augmentation options				
Description	Additional network capacity (MW)	Expected cost (\$ million)	New easement length (km)	Lead time
<p>Option 1:</p> <ul style="list-style-type: none"> Operate the future Cultana Yadnarie 132 kV double-circuit line (built as part of the Eyre Peninsula Link RIT T) at 275 kV by establishing a 275 kV substation at Yadnarie. 	300	100 ¹⁰⁵ Class 5a (± 30%)	-	Short
Adjustment factors and risk				
Option	Adjustment factors applied	Known and unknown risks applied		
Option 1	Cost was informed by an internal ElectraNet study, with cost components for lower voltages than AEMO ordinarily assesses using the AEMO Transmission Cost Database.	Cost was informed by an internal ElectraNet study, with cost components for lower voltages than AEMO ordinarily assesses using the AEMO Transmission Cost Database.		

¹⁰⁴ Additional augmentation is required in Mid-North when the combination of generation in S3, S4, S5, S6, S7, S8, S9 >2,400 MW or in Eyre Peninsula when S5, S8, S9 > 1,125 MW.

¹⁰⁵ This cost estimate has been updated to 2022-23 dollars as informed by internal ElectraNet study.

4.4.9 Western Eyre Peninsula (S9)

Summary				
<p>The Western Eyre Peninsula REZ shares the same electrical network as the Eastern Eyre Peninsula. It has good solar and moderate wind resources. There are no generators currently connected or committed within this REZ.</p>				
Existing network capability				
<p>There is no additional network capacity within this REZ. The capability of this zone to accommodate new generation is subject to the MN1-SA mid-north and NSA1 northern group constraint¹⁰⁶.</p>				
Augmentation options				
Description	Additional network capacity (MW)	Expected cost (\$ million)	New easement length (km)	Lead time
<p>Option 1:</p> <ul style="list-style-type: none"> 275 kV double-circuit line from Cultana/Corraberra Hill to a new Elliston substation. 	950	862 Class 5b (± 50%)	254	Long
<p>Option 2:</p> <ul style="list-style-type: none"> 275 kV single-circuit line from Yadnarie to a new Elliston substation. <p><i>Pre-requisite: S8 Option 1</i></p>	500	424 Class 5b (± 50%)	144	Long
<p>Option 3:</p> <ul style="list-style-type: none"> New Elliston substation. Single-circuit 275 kV line from Cultana/Corraberra Hill to Elliston. Single-circuit 275 kV line from Yadnarie to Elliston. <p><i>Pre-requisite: S8 Option 1</i></p>	1,000	1,058 Class 5b (± 50%)	398	Long
Adjustment factors and risk				
Option	Adjustment factors applied	Known and unknown risks applied		
Option 1	<ul style="list-style-type: none"> Land Use: Grazing Jurisdiction: SA – Eyre Peninsula Project network element size: # of total Bays 11 – 15/Above 200 km Location (regional/distance factors): Remote Delivery timetable: Long 	<ul style="list-style-type: none"> Known risks: BAU Unknown risks: Class 5b 		
Option 2	<p>As per Option 1 except:</p> <ul style="list-style-type: none"> Project network element size: 100 to 200 km/# of total Bays 6 – 10 	<ul style="list-style-type: none"> Known risks: BAU Unknown risks: Class 5b 		
Option 3	<p>As per Option 1 except:</p> <ul style="list-style-type: none"> Project network element size: Above 200 km/# of total Bays 16 – 20 	<ul style="list-style-type: none"> Known risks: BAU Unknown risks: Class 5b 		

¹⁰⁶ Additional augmentation is required in Mid-North when the combination of generation in S3, S4, S5, S6, S7, S8, S9 >2,400 MW or in Eyre Peninsula when S5, S8, S9 > 1,125 MW.

4.4.10 South East SA Coast (S10)

Summary				
<p>The South East Coast REZ has been identified for the offshore wind resource potential in relatively shallow waters close to shore, with a connection point near to the South East SA. There is currently interest in this area of approximately 600 MW, but projects have not developed sufficiently at this stage to be considered anticipated.</p>				
Existing network capability				
<p>SA Coast REZ connects to an offshore collection node in the South East SA REZ. The network limit for this REZ is included as part of the SESA-CSA 650 MW sub-regional limit. There are no augmentation options specifically for this REZ. The associated augmentations are the VIC-SESA and SESA-CSA flow path augmentations (see Sections 3.11 and 3.12).</p>				
Augmentation options				
Description	Additional network capacity (MW)	Expected cost (\$ million)	New easement length (km)	Lead time
See Sections 3.11 and 3.12 (VIC-SESA and SESA-CSA augmentations)				
Adjustment factors and risk				
Option	Adjustment factors applied	Known and unknown risks applied		
See Sections 3.11 and 3.12 (VIC-SESA and SESA-CSA augmentations)				

4.4.11 South Australia group constraints and transmission limit constraints

MN1 group constraint

Summary				
<p>The Group Constraint MN1 represents the generation build limit applied to S3, S4, S5, S6, S7, S8, and S9 REZs. This constraint is necessary because these REZs all must export any additional power generation south towards Adelaide primarily along the existing four 275 kV parallel circuits from Davenport to near Adelaide (Para). This corridor of the network forms a bottleneck for these REZs.</p> <p>The application of this group constraint will be removed for the <i>Green Energy Exports</i> scenario.</p>				
Existing network capability				
<p>The individual REZs which form this group constraint each have their own individual existing network capabilities. The collective generation build from S3 to S9 cannot exceed 2,400 MW without additional network augmentation between Davenport and Adelaide.</p>				
Augmentation options				
Description	Additional network capacity (MW)	Expected cost (\$ million)	New easement length (km)	Lead time
Augmentation to alleviate the MN1 group constraint is linked to the S3 Mid-North REZ development				
<p>S3 Option 1 (part of preparatory activities):</p> <ul style="list-style-type: none"> Build a 275 kV double-circuit line between Bunday and Para¹⁰⁷. Build a 275 kV double-circuit line from Brinkworth to cut into Bungama-Blyth West 275 kV circuit. Disconnect existing Waterloo-Templers 132 kV line at each end. Build a 132 kV single-circuit line from Templers West to Templers. 1 x 160 MVA, 275/132 kV transformer at Templers West. <p><i>Provided by ElectraNet – see Section 1.2.</i></p>	900	416 ¹⁰⁸ Class 5b (± 50%)	136	Short
<p>S3 Option 2:</p> <ul style="list-style-type: none"> Build a 330 kV double-circuit line from Bunday to Globe Derby. 	1,150	740 Class 5b (± 50%)	150	Short
<p>S3 Option 3:</p> <ul style="list-style-type: none"> Build a 275 kV double-circuit line from Bunday to Cultana. <ul style="list-style-type: none"> Stage 1: 275 kV double-circuit from Bunday to a new substation near Yunta. Stage 2: 275 kV double-circuit from a new substation near Yunta to Cultana. 	800	1,434 Class 5b (± 50%)	430	Short
S3 Option 4:	1,000	1,434	390	Short

¹⁰⁷ Additional network hosting capacity is South of Robertstown towards Adelaide. This option does not alleviate the MN1 SA group constraint.

¹⁰⁸ See Preparatory Activities page, at <https://aemo.com.au/consultations/current-and-closed-consultations/2023-transmission-expansion-options-report-consultation>.

<ul style="list-style-type: none"> Build a 330 kV double-circuit line from Bunday to Cultana. 		Class 5b (± 50%)		
Adjustment factors and risk				
Option	Adjustment factors applied		Known and unknown risks applied	
S3 Option 1	Preparatory Activity		Preparatory Activity	
S3 Option 2	<ul style="list-style-type: none"> Land Use: Grazing/Developed area Jurisdiction: SA – Adelaide and Fleurieu Project network element size: # of total Bays 1 – 5/100 to 200 km Location (regional/distance factors): Regional/Urban Delivery timetable: Long/Optimum 		Known risks: BAU except: <ul style="list-style-type: none"> Market activity: Tight Unknown risks: Class 5b 	
S3 Option 3	<ul style="list-style-type: none"> Land Use: Grazing Jurisdiction: SA – Adelaide and Fleurieu/SA – York and North Project network element size: # of total Bays 6 – 10/Above 200 km Location (regional/distance factors): Regional Delivery timetable: Long 		Known risks: BAU except: <ul style="list-style-type: none"> Market activity: Tight Unknown risks: Class 5b 	
S3 Option 4	As per Option 3		As per Option 3	

NSA1 group constraint

Summary				
<p>The Group Constraint NSA1 represents the generation build limit applied to S5, S8, and S9 REZs. This constraint is necessary because these REZs all must export power through the Davenport – Cultana 275 kV circuits. This corridor of the network forms a bottleneck for these REZs.</p> <p>The application of this group constraint will be removed for the <i>Green Energy Exports</i> scenario.</p>				
Existing network capability				
<p>The individual REZs which form this group constraint each have their own individual existing network capabilities. The collective generation build for S5, S8 and S9 cannot exceed 1,125 MW without additional network augmentation between Davenport and Cultana.</p>				
Augmentation options				
Description	Additional network capacity (MW)	Expected cost (\$ million)	New easement length (km)	Lead time
Augmentation to alleviate the NSA1 group constraint is linked to the S5 Northern SA and S8 Eastern Eyre Peninsula REZ developments.				
Option 1: <ul style="list-style-type: none"> Build a 275 kV double-circuit line from Davenport-Cultana. 	1,200	268 Class 5b (± 50%)	75	Short
Option 2: <ul style="list-style-type: none"> Operate the future Cultana Yadnarie 132 kV double-circuit line (built as part of the Eyre Peninsula Link RIT T) at 275 kV by establishing a 275 kV substation at Yadnarie. 	300	100 Class 5a (± 30%)	-	Short
Adjustment factors and risk				
Option	Adjustment factors applied	Known and unknown risks applied		
Option 1	<ul style="list-style-type: none"> Land Use: Grazing Jurisdiction: SA – York and North Project network element size: # of total Bays 1 – 5/10 to 100 km Location (regional/distance factors): Remote Delivery timetable: Long 	Known risks: BAU except: <ul style="list-style-type: none"> Market Activity: Tight Unknown risks: Class 5b		
Option 2	Cost estimate provided by ElectraNet.	<ul style="list-style-type: none"> Cost estimate provided by ElectraNet. 		

4.5 Tasmania

4.5.1 North East Tasmania (T1)

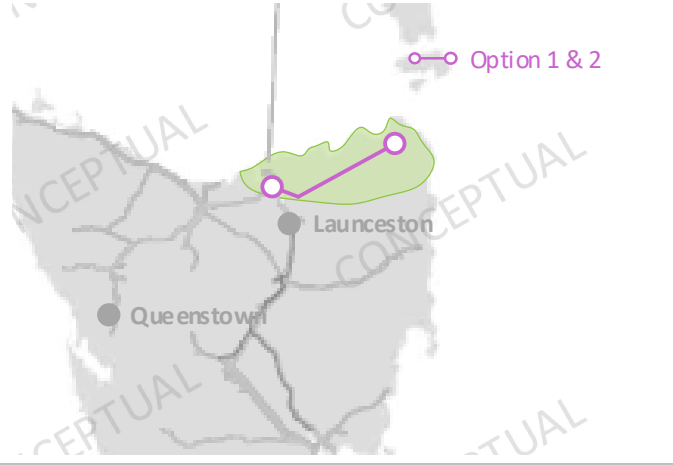
Summary				
<p>This REZ has a good quality wind resources and moderate solar resources. North East Tasmania is distanced from the proposed Marinus Link augmentations and therefore upgrades are less influenced by the proposed new interconnector (see Section 3.10).</p>				
Existing network capability				
<p>Currently there is no capacity on the 110 kV network from Hadspen to Derby. There is approximately 400 MW of VRE resource capacity available within the vicinity of George Town. The capability of this zone to accommodate new generation is subject to the NET1 northeast Tasmania group constraint¹⁰⁹.</p>				
Augmentation options				
Description	Additional network capacity (MW)	Expected cost (\$ million)	New easement length (km)	Lead time
<p>Option 1:</p> <ul style="list-style-type: none"> 220 kV double-circuit line between a new substation in George Town area, and a new substation in far north-east Tasmania. 220 kV double-circuit line connecting the new George Town substation to the existing George Town substation. 	800	400 Class 5b (± 50%)	85	Medium
<p>Option 2:</p> <ul style="list-style-type: none"> Second 220 kV double-circuit line between the new substations in George Town and far north-east Tasmania, strung one side only. <p><i>Prerequisite: T1 Option 1</i></p>	800	269 Class 5b (± 50%)	80	Long
Adjustment factors and risk				
Option	Adjustment factors applied	Known and unknown risks applied		
Option 1	<ul style="list-style-type: none"> Land Use: Grazing/Developed area Jurisdiction: TAS – Northern Project network element size: # of total Bays 1 – 5/10 to 100 km Location (regional/distance factors): Regional/Urban Delivery timetable: Long 	<ul style="list-style-type: none"> Known risks: Environmental Offset Risk – High, Market Activity – Tight, Others – BAU Unknown risks: Class 5b 		
Option 2	<ul style="list-style-type: none"> As per Option 1 above 	<ul style="list-style-type: none"> Known risks: Environmental Offset Risk – High, Others – BAU Unknown risks: Class 5b 		

¹⁰⁹ Additional augmentation is required in North East Tasmania when the combination of generation in T1 and T5 is greater than 1,600 MW.

4.5.2 North West Tasmania (T2)

Summary				
<p>This REZ has excellent quality wind resources and good pumped hydro resources. The North West Tasmania augmentation options are highly dependent on Marinus Link, with some REZ network capacity increase already included in the proposed Marinus Link AC augmentations.</p>				
Existing network capability				
<p>The current total REZ transmission limit for existing (112 MW Granville Harbour wind farm) and new VRE before any network upgrade in North West Tasmania is approximately 277 MW for peak demand and summer typical conditions and 112 MW for winter reference condition.</p> <p>Note this REZ is affected by voltage stability constraints for VRE connection at Farrell 220 kV substation. Future REZ generators are assumed to have a runback scheme in place to reduce generation output post contingency to within network capacity for lines currently covered by the Network Control System Protection Scheme (NCSPS), but not for new transmission lines.</p>				
Augmentation options				
Description	Additional network capacity (MW)	Expected cost (\$ million)	New easement length (km)	Lead time
<p>Option 1:</p> <p>Prior to (without) Marinus Link:</p> <ul style="list-style-type: none"> Build a new 220 kV switching station at Staverton and cut-in all Sheffield-Mersey Forth 220 kV lines at Staverton. Build a new double-circuit Staverton-Hampshire Hills 220 kV line. (note this is part of the TAS-VIC Option 1 augmentations). Build a new Hampshire Hills wind collector station. <p>With Marinus Link:</p> <ul style="list-style-type: none"> Build new Hampshire Hills wind collector station. 	800	272 (prior to (without) MarinusLink)/ 28 (with MarinusLink) Class 5a (± 30%)	Without Marinus: 50 With Marinus: -	Short
<p>Option 2:</p> <ul style="list-style-type: none"> Build new “Farrell 2” wind collector station on west coast Tasmania (nearby existing Farrell substation) and establish new double-circuit Farrell2-Hampshire Hills 220 kV line. <p><i>Pre-requisite: TAS-VIC Option 2, T2 Option 1.</i></p>	500	258 Class 5a (± 30%)	65	Long
<p>Option 3:</p> <ul style="list-style-type: none"> Build double-circuit West Montagu-Hampshire 220 kV line. Build a second 220 kV double-circuit line from Hampshire Hills to Burnie to Heybridge. <p><i>Pre-requisite: TAS-VIC Option 2, T2 Option 1.</i></p>	800	534 Class 5a (± 30%)	132	Medium
Adjustment factors and risk				
Option	Adjustment factors applied	Known and unknown risks applied		
Option 1	<ul style="list-style-type: none"> Land Use: Grazing/Developed area Jurisdiction: TAS – North West Project network element size: 10 to 100 km/# of total Bays 6 – 10 Location (regional/distance factors): Regional Delivery timetable: Long 	<ul style="list-style-type: none"> Known risks: Environmental Offset Risk – High, Market Activity – Tight, Others – BAU Unknown risks: Class 5a 		

Option 2	As per Option 1 above	<ul style="list-style-type: none"> • Known risks: Environmental Offset Risk – High, Others – BAU • Unknown risks: Class 5a
Option 3	<p>As per Option 1 above except:</p> <ul style="list-style-type: none"> • Project network element size: 100 to 200 km, no. of bays 11 – 15 	<ul style="list-style-type: none"> • Known risks: Environmental Offset Risk – High, Market Activity – Tight, Others – BAU • Unknown risks: Class 5a

4.5.3 Central Highlands (T3)

Summary				
<p>This REZ has excellent quality wind resources and has good pumped hydro resources. It is located close to major load centres at Hobart. The Tasmania Central Highlands augmentation options are influenced by the Marinus Link augmentations, with REZ network capacity increase already included in the proposed Marinus Link Palmerston to Sheffield 220 kV AC augmentations.</p>				
Existing network capability				
<p>The current total REZ transmission limit for existing (144 MW Wild Cattle Hill wind farm) and new VRE before any network upgrade in the Central Highlands is approximately 527 MW for peak demand and 668 MW for winter reference condition. VRE development opportunities are anticipated around the Waddamana substation.</p> <p>Note that a runback scheme is not considered for any new transmission lines.</p>				
Augmentation options				
Description	Additional network capacity (MW)	Expected cost (\$ million)	New easement length (km)	Lead time
<p>Option 1:</p> <ul style="list-style-type: none"> Build a Palmerston-Waddamana 220 kV double-circuit line. <p><u>Prior to (without) MarinusLink:</u></p> <ul style="list-style-type: none"> If before Marinus Link 1, bring forward the rebuild of Palmerston-Sheffield 220 kV line as double-circuit and build 2 x power flow controllers on the 2 x 220 kV transmission lines from Palmerston-Sheffield. <p><u>With MarinusLink:</u></p> <ul style="list-style-type: none"> If after Marinus Link 1, build 2 x power flow controllers on the 2 x 220 kV transmission lines from Palmerton-Sheffield. 	690	494 (prior to (without) MarinusLink)/ 224 (after Marinus) Class 5a (± 30%)	270	Short
<p>Option 2:</p> <ul style="list-style-type: none"> Build a second Palmerston-Sheffield 220 kV double-circuit line. <p><i>Pre-requisite: TAS-VIC Option 2, T3 Option 1.</i></p>	675	274 Class 5a (± 30%)	95	Long
Adjustment factors and risk				
Option	Adjustment factors applied	Known and unknown risks applied		
Option 1	<ul style="list-style-type: none"> Land Use: Grazing/Developed area Jurisdiction: TAS – South Project network element size: # of total Bays 1 – 5/10 to 100 km Location (regional/distance factors): Regional Delivery timetable: Long 	<p>Known Risks:</p> <ul style="list-style-type: none"> Environmental offset risks : High Market activity : Tight Others: BAU <p>Unknown risks: Class 5a</p>		
Option 2	<ul style="list-style-type: none"> Land Use: Grazing/Developed area Jurisdiction: TAS – South Project network element size: # of total Bays 1 – 5/10 to 100 km Location (regional/distance factors): Regional Delivery timetable: Long 	<ul style="list-style-type: none"> Known risks: Environmental Offset Risk – High, Others – BAU Unknown risks: Class 5a 		

4.5.4 North West Tasmania Coast (T4)

Summary				
<p>The North West Tasmania Coast REZ has been identified for the offshore wind resource potential in relatively shallow waters close to shore, with a connection point close to existing 220 kV networks.</p>				
Existing network capability				
<p>North West Tasmania coast REZ connects to the 220 kV network within the North West REZ. The total REZ transmission network limit for existing and new VRE is included as part of the North West REZ limit of approximately 277 MW for peak demand and summer typical conditions and 112 MW for winter reference condition.</p>				
Augmentation options				
Description	Additional network capacity (MW)	Expected cost (\$ million)	New easement length (km)	Lead time
<p>Option 1:</p> <ul style="list-style-type: none"> Build a new Burnie-Heybridge-Sheffield 220 kV double-circuit line. <p><i>Pre-requisites: TAS-VIC Option 2.</i></p>	1,360	206 Class 5a (± 30%)	53	Long
Adjustment factors and risk				
Option	Adjustment factors applied	Known and unknown risks applied		
Option 1	<ul style="list-style-type: none"> Land Use: Developed area/Grazing Jurisdiction: TAS – South/TAS – North West Project network element size: 10 to 100 km/# of total Bays 6 – 10 Location (regional/distance factors): Regional Delivery timetable: Long 	<ul style="list-style-type: none"> Known risks: Environmental Offset Risk – High, Others – BAU Unknown risks: Class 5a 		

4.5.5 North East Tasmania Coast (T5)

Summary				
<p>Due to recent enquiries by offshore wind proponents around the North East Coast of Tasmania, the North East Tasmania Coast REZ has been identified for the offshore wind resource potential in relatively shallow waters close to shore, with a connection point close to existing 220 kV George Town substation.</p>				
Existing network capability				
<p>North East Tasmania coast REZ connects to the 220 kV network within the North East REZ in the vicinity of George Town. The total REZ transmission network limit for existing and new VRE is included as part of the North East Tasmania NET1 group constraint with a combined network limit of 1,600 MW for offshore wind and onshore VRE from T1.</p>				
Augmentation options				
Description	Additional network capacity (MW)	Expected cost (\$ million)	New easement length (km)	Lead time
<p>Option 1:</p> <ul style="list-style-type: none"> Build a new George Town-Sheffield 220 kV double-circuit line. Build 2 x power flow controllers on the 2 x 220 kV double-circuit line between George Town-Hadspen. <p><i>Pre-requisite: TAS-VIC Option 2.</i></p>	900	307 Class 5a (± 30%)	68	Long
Adjustment factors and risk				
Option	Adjustment factors applied	Known and unknown risks applied		
Option 1	<ul style="list-style-type: none"> Land Use: Grazing/Developed area Jurisdiction: TAS – Northern/TAS – North West Project network element size: # of total Bays 1 – 5/10 to 100 km Location (regional/distance factors): Regional Delivery timetable: Long 	<ul style="list-style-type: none"> Known risks: Environmental Offset Risk – High, Others – BAU Unknown risks: Class 5a 		



4.6 Victoria

4.6.1 Ovens Murray (V1)

Summary				
<p>The Ovens Murray REZ has been identified as a candidate REZ due to this REZ having good pumped hydro resources. There is currently 770 MW of installed hydro generation within this zone.</p>				
Existing network capability				
<p>The current network capacity in Ovens Murray is approximately 350 MW.</p>				
Augmentation options				
Description	Additional network capacity (MW)	Expected cost (\$ million)	New easement length (km)	Lead time
<p>There are no associated augmentations with this REZ.</p>				

4.6.2 Murray River (V2)

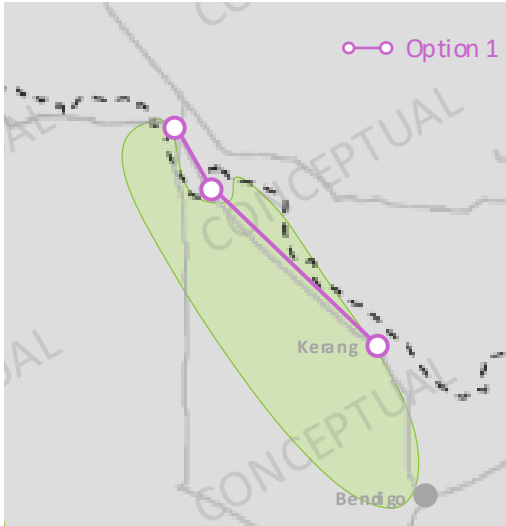
Summary				
<p>The Murray River REZ has good solar resources. Despite being remote and electrically weak, this REZ has attracted significant investment in solar generation. Voltage stability and thermal limits currently restrict the output of generators within this REZ.</p> <p>The proposed VNI West project could upgrade transfer capability between Victoria and New South Wales via Bulgana, and significantly increase the ability for renewable generation to connect in this zone. As noted in the 2022 <i>Victorian Annual Planning Report</i>, voltage oscillation constraints affecting this area will be reviewed after completion of the Western Renewables Link and Project EnergyConnect augmentations.</p>				
Existing network capability				
<p>The current REZ transmission limits for existing and new VRE before any network upgrade in Murray River is approximately 440 MW for peak demand and summer typical conditions and 640 MW for winter reference condition.</p> <p>No additional capacity to connect new generation.</p>				
Augmentation options				
Description	Additional network capacity (MW)	Expected cost (\$ million)	New easement length (km)	Lead time
Option 1: ¹¹⁰ <ul style="list-style-type: none"> New 220 kV double-circuit line between Red Cliffs – Wemen – Kerang. Establish new substations close to Redcliff and Kerang. <i>Pre-requisite: VNI West (Bulgana)</i>	800	912 Class 5b (± 50%)	275	Long
Adjustment factors and risk				
Option	Adjustment factors applied	Known and unknown risks applied		
Option 1	<ul style="list-style-type: none"> Land Use: Grazing Jurisdiction: VIC – North West Project network element size: # of total Bays 11 – 15/Below 1 km/Above 200 km Location (regional/distance factors): Regional Delivery timetable: Long 	Known Risks: <ul style="list-style-type: none"> Cultural heritage: High Outage restrictions: High/BAU Project complexity: Highly complex Environmental offset risks : High Compulsory acquisition: High Others: BAU Unknown risks: Class 5b		

¹¹⁰ For the practicality of ISP modelling, AEMO has included this REZ option to enable increased generation connection interest near Kerang.

4.6.3 Western Victoria (V3)

Summary				
<p>The Western Victoria REZ has good to excellent quality wind resources. The existing and committed renewable generation within this REZ exceeds 1 GW, all of which is from wind generation. The current network is constrained west of Ballarat and cannot support any further connection of renewable generation without transmission augmentation.</p> <p>The Western Renewables Link is an anticipated project, with the preferred option to expand generation within this zone.</p> <p>REZ augmentation options shown take into account the change to the WRL scope as part of the VNI West RIT-T preferred option, and assumes 500 kV from Sydenham to Bulgana.</p>				
Existing network capability				
<p>The current REZ transmission limits for existing and new VRE before any network upgrade in Western Victoria is split between two modelling constraints:</p> <p><u>V3 East</u> Approximately 600 MW for peak demand and summer typical conditions and 800 MW for winter reference condition</p> <p><u>V3 West</u> Approximately 780 MW for peak demand and summer typical conditions and 980 MW for winter reference condition.</p> <p>Network capacity is anticipated to be sufficient for existing and committed generation following completion of the Western Renewables Link.</p>				
Augmentation options				
Description	Additional network capacity (MW)	Expected cost (\$ million)	New easement length (km)	Lead time
V3 East				
Option 1: New 220 kV single-circuit line from Elaine to Moorabool.	600	163 Class 5b (± 50%)	43	Medium
V3 West				
There are no associated augmentations with V3 West.				
Adjustment factors and risk				
Option	Adjustment factors applied	Known and unknown risks applied		
V3 East				
Option 1	<ul style="list-style-type: none"> Land Use: Grazing Jurisdiction: VIC – South West Project network element size: # of total Bays 1 – 5/10 to 100 km Location (regional/distance factors): Regional Delivery timetable: Long 	<p>Known risks:</p> <ul style="list-style-type: none"> Cultural heritage: High Outage restrictions: High Project complexity: Highly complex Environmental offset risks: High Market Activity: Tight Compulsory acquisition: High Others: BAU <p>Unknown risks: Class 5b</p>		

4.6.4 South West Victoria (V4)

Summary				
<p>The South West Victoria REZ has moderate to good quality wind resources in close proximity to the 500 kV and 220 kV networks in the area.</p> <p>The total committed and in-service wind generation in the area exceeds 2 GW.</p> <p>The Victorian Government has outlined its vision for offshore wind and has set targets for 2 GW of offshore wind capacity by 2032, 4 GW by 2035 and 9 GW by 2040. The Government has announced that VicGrid will provide a coordinated transmission connection point near Portland¹¹¹.</p> <p>VicGrid is currently undertaking consultation on the development of this infrastructure and AEMO will continue to co-ordinate with VicGrid on this matter.</p>				
Existing network capability				
<p>The current REZ transmission limits for existing and new VRE before any network upgrade in South West Victoria are limited by voltage stability, and is modelled with the SWV1 group constraint.</p> <p>This limit is approximately 1,700 MW for peak demand, summer typical and winter reference conditions, prior to commissioning of the Victorian Government RDP: Mortlake turn in project¹¹².</p>				
Augmentation options				
Description	Additional network capacity (MW)	Expected cost (\$ million)	New easement length (km)	Lead time
See Section 4.6.9 (SWV1 group constraint augmentations)				
Adjustment factors and risk				
Option	Adjustment factors applied	Known and unknown risks applied		
See Section 4.6.9 (SWV1 group constraint augmentations)				

¹¹¹ See <https://engage.vic.gov.au/project/offshore-wind-transmission-in-gippsland-and-portland/page/development-and-engagement-roadmap>.

¹¹² RDP 1 – Stage 1: Mortlake turn in alleviates existing voltage constraint between Moorabool and Mortlake 500 kV Terminal Stations enabling 1,500 MW of additional generation output (<http://www.gazette.vic.gov.au/gazette/Gazettes2022/GG2022S547.pdf>). See https://aemo.com.au/-/media/files/electricity/nem/planning_and_forecasting/vapr/2022/2022-victorian-annual-planning-report.pdf?la=en.

4.6.5 Gippsland (V5)

Summary				
<p>The Gippsland REZ has moderate quality wind resources, in proximity to the 500 kV networks.</p> <p>The Victorian Government has outlined its vision for offshore wind and has set targets for 2 GW of offshore wind capacity by 2032, 4 GW by 2035 and 9 GW by 2040. The government has announced that VicGrid will provide a coordinated transmission connection point near the Gippsland Coast¹¹³.</p> <p>VicGrid is currently undertaking consultation on the development of this infrastructure and AEMO will continue to co-ordinate with VicGrid on this matter.</p>				
Existing network capability				
<p>Due to the strong network in this REZ (with multiple 500 kV and 220 kV lines from Latrobe Valley to Melbourne designed to transport energy from major Victorian brown coal power station), significant generation can be accommodated.</p> <p>However, transfer capacity from Gippsland, through the Latrobe Valley to major load centres is restricted by the SEVIC1 transmission limit and group constraint.</p> <p>See Section 4.6.9 (SEVIC1 group constraint augmentations).</p>				
Augmentation options				
Description	Additional network capacity (MW)	Expected cost (\$ million)	New easement length (km)	Lead time
See Section 4.6.9 (SEVIC1 group constraint augmentations)				
Adjustment factors and risk				
Option	Adjustment factors applied	Known and unknown risks applied		
See Section 4.6.9 (SEVIC1 group constraint augmentations)				

¹¹³ See <https://engage.vic.gov.au/download/document/31115>.

4.6.6 Central North Vic (V6)

Summary				
<p>The Central North Victoria REZ has moderate quality wind and solar resources. In addition to the currently in service and committed solar farms, there are enquires for approximately 2.5 GW of additional solar.</p>				
Existing network capability				
<p>The current REZ transmission limits for existing and new VRE before any network upgrade in Central North Victoria are approximately 650 MW for peak demand and summer typical conditions and 1,300 MW for the winter reference condition.</p>				
Augmentation options				
Description	Additional network capacity (MW)	Expected cost (\$ million)	New easement length (km)	Lead time
<p>Option 1:</p> <ul style="list-style-type: none"> New double-circuit 220 kV line from Shepparton to Dederang via Glenrowan. 	250	709 Class 5b (± 50%)	175	Long
<p>Option 2:</p> <ul style="list-style-type: none"> New double-circuit 220 kV line from Near Shepparton – Near Bendigo – Near Kerang. 	500	1,110 Class 5b (± 50%)	290	Long
<p>Option 3:</p> <ul style="list-style-type: none"> New double-circuit 500 kV line from Shepparton – Near Kerang. 	1,500	1,077 Class 5b (± 50%)	160	Long
Adjustment factors and risk				
Option	Adjustment factors applied	Known and unknown risks applied		
Option 1	<ul style="list-style-type: none"> Land Use: Grazing Jurisdiction: VIC – Northern Project network element size: 100 to 200 km/# of total Bays 6 – 10 Location (regional/distance factors): Regional Delivery timetable: Long 	<p>Known Risks:</p> <ul style="list-style-type: none"> Cultural heritage: High Outage restriction : High Project complexity: Highly complex Environmental offset risks: High Compulsory acquisition: High Others: BAU <p>Unknown risks: Class 5b</p>		
Option 2	<ul style="list-style-type: none"> Land Use: Grazing Jurisdiction: VIC – Northern Project network element size: Above 200 km/# of total Bays 6 – 10 Location (regional/distance factors): Regional Delivery timetable: Long 	<p>Known Risks:</p> <ul style="list-style-type: none"> Cultural heritage : High Project complexity : Highly complex Environmental offset risks : High Compulsory acquisition : High Others: BAU <p>Unknown risks: Class 5b</p>		
Option 3	<ul style="list-style-type: none"> Land use: Grazing Project network element size: 100 to 200 km, no. of bays 1-5 Proportion of environmentally sensitive areas: 50% Location (regional/distance factors): Regional Delivery Timetable: Long 	<p>Known risks:</p> <ul style="list-style-type: none"> Cultural heritage : High Project complexity : Highly complex Environmental offset risks : High Compulsory acquisition : High Others: BAU <p>Unknown risks: Class 5b</p>		

4.6.7 Gippsland Coast (V7)

Summary				
<p>The Gippsland Coast REZ has been identified for offshore wind resource potential in relatively shallow waters close to shore, with a connection point close to existing 500 kV networks at Loy Yang/Hazelwood. There is currently significant interest in this area from a number of offshore wind farms, but projects have not developed sufficiently at this stage to be considered anticipated. Augmentation options below will provide capacity for onshore and offshore connection.</p> <p>The Victorian Government has outlined its vision for offshore wind and has set targets for 2 GW of offshore wind capacity by 2032, 4 GW by 2035 and 9 GW by 2040. The government has announced that VicGrid will provide a coordinated transmission connection point near the Gippsland Coast. New transmission lines will also be developed where needed to link the common connection points with the existing energy grid.</p> <p>AEMO understands from the Victorian Government and VicGrid that transmission augmentation projects for Gippsland REZ are likely to be delivered as a dedicated asset of some kind. This may need to be treated similar to a generation connection asset in the ISP model, rather than like a network augmentation.</p> <p>VicGrid is currently undertaking consultation on the development of this infrastructure and AEMO will continue to co-ordinate with VicGrid on this matter. This document does not pre-empt the outcome of the VicGrid consultation. The options in this section are for ISP modelling purposes.</p>		<p>*Coastal location of Option 1 & 2 is expected to be within the dotted box, as per the Victorian offshore wind transmission development & engagement roadmap¹¹⁴.</p>		
Existing network capability				
Gippsland offshore REZ connects to the 500 kV network in the Gippsland REZ. See Section 4.6.5 for a description of existing network capability.				
Augmentation options				
Description	Additional network capacity (MW)	Expected cost (\$ million)	New easement length (km)	Lead time
<p>Option 1:</p> <ul style="list-style-type: none"> New 500 kV double-circuit line from Hazelwood to vicinity of Gippsland coast. 2 x 500/220 kV transformers. 	2,000 ¹¹⁵	684 Class 5b (± 50%)	16	Long
<p>Option 2:</p> <ul style="list-style-type: none"> New 500 kV double-circuit line from Hazelwood to vicinity of Gippsland coast. 2 x 500/220 kV transformers. <p><i>Pre-requisite: Option 1</i></p>	6,000	684 Class 5b (± 50%)	16	Long
Adjustment factors and risk				
Option	Adjustment factors applied	Known and unknown risks applied		
Option 1	<ul style="list-style-type: none"> Land use: Grazing Project network element size: 10 to 100 km, no. of bays 6-10 	<p>Known risks:</p> <ul style="list-style-type: none"> Project complexity – Highly complex Environmental offset risks – High Cultural heritage – High 		

¹¹⁴ At <https://engage.vic.gov.au/download/document/31115>.

¹¹⁵ May be subject to additional operational limits.



	<ul style="list-style-type: none"> • Proportion of environmentally sensitive areas: 50% • Location (regional/distance factors): Regional • Delivery Timetable: Long 	<ul style="list-style-type: none"> • Outage restrictions – High • Compulsory acquisition – High • Others – BAU <p>Unknown risks: Class 5b</p>
Option 2	As per Option 1.	As per Option 1.

4.6.8 Portland Coast (V8)

Summary				
<p>The Portland Coast REZ has been identified for offshore wind resource potential in relatively shallow waters close to shore, with a connection point close to existing 500 kV networks at APD/Heywood.</p> <p>The Victorian Government has outlined its vision for offshore wind and has set targets for 2 GW of offshore wind capacity by 2032, 4 GW by 2035 and 9 GW by 2040. The government has announced that VicGrid will provide a coordinated transmission connection point near Portland¹¹⁶.</p> <p>VicGrid is currently undertaking consultation on the development of this infrastructure and AEMO will continue to co-ordinate with VicGrid on this matter.</p>				
Existing network capability				
<p>The network capacity available for V8 is the same as V4 South West Victoria. REZ augmentation options are common to those shown for V4 and SWV1.</p>				
Augmentation options				
Description	Additional network capacity (MW)	Expected cost (\$ million)	New easement length (km)	Lead time
See Section 4.6.9 (SWV1 group constraint augmentations)				
Adjustment factors and risk				
Option	Adjustment factors applied	Known and unknown risks applied		
See Section 4.6.9 (SWV1 group constraint augmentations)				

¹¹⁶ [Offshore Wind Transmission Development and Engagement Roadmap | Offshore Wind Transmission In Gippsland and Portland | Engage Victoria](#)

4.6.9 Victoria group constraints and transmission limit constraints

SWV1

Summary				
<p>The group constraint SWV1 represents the generation build limit applied to V4, V8 REZs and the VIC-SESA Heywood interconnector. Upgrade options associated with this group constraint may be built to improve the generation capacity in South-West Victoria. These augmentations will facilitate generation transmission to APD and Melbourne loads.</p>				
Existing network capability				
<p>The network capacity available for SWV1 is the same as for V4 South West Victoria and V8 Portland Coast. REZ augmentation options are common to those shown for V4.</p> <p>Under the ISP preparatory activities function, AEMO Victoria Planning is considering additional options across SWV1.</p> <p>Augmentation options and outcomes from the preparatory activity report have been incorporated below.</p>				
Augmentation options ¹¹⁷				
Description	Additional network capacity (MW)	Expected cost (\$ million) ¹¹⁸	New easement length (km)	Lead time
<p>Option 1:</p> <ul style="list-style-type: none"> Moorabool – Geelong 220 kV line upratings via terminal station augmentations. <p><i>Provided by AEMO (Victoria Planning) – see Section 1.2.</i></p>	Nil.	58 Class 5a (± 30%)	0	Long
<p>Option 1A:</p> <ul style="list-style-type: none"> New 500 kV single-circuit line from Mortlake – Moorabool. Sydenham line upratings. <p><i>Pre-requisite: Option 1</i></p> <p><i>Provided by AEMO (Victoria Planning) – see Section 1.2.</i></p>	1,500	678 Class 5a (± 30%)	148	Long
<p>Option 1B:</p> <ul style="list-style-type: none"> Moorabool – Sydenham 500 kV single-circuit. <p><i>Pre-requisite: Option 1A</i></p> <p><i>Provided by AEMO (Victoria Planning) – see Section 1.2.</i></p>	1,750	962 Class 5a (± 30%)	64	Long
<p>Option 1C:</p> <ul style="list-style-type: none"> Heywood – Mortlake 500 kV single-circuit. <p><i>Pre-requisite: Option 1B</i></p> <p><i>Provided by AEMO (Victoria Planning) – see Section 1.2.</i></p>	1,750	1,290 Class 5a (± 30%)	96	Long
<p>Option 2A:</p> <ul style="list-style-type: none"> New Mortlake – Bulgana 500 kV single circuit. <p><i>Pre-requisite: Option 1</i></p> <p><i>Provided by AEMO (Victoria Planning) – see Section 1.2.</i></p>	1,950	578 Class 5a (± 30%)	147	Long
<p>Option 2B:</p>	2,900	751	147	Long

¹¹⁷ Pre-requisite RDP and RIT-T projects, see <http://www.gazette.vic.gov.au/gazette/Gazettes2022/GG2022S547.pdf> (Mortlake turn in), <http://www.gazette.vic.gov.au/gazette/Gazettes2022/GG2022S547.pdf> (SW REZ Minor Augmentations), and <https://www.gazette.vic.gov.au/gazette/Gazettes2023/GG2023S267.pdf#page=1> (VNI West).

¹¹⁸ Cost estimates within the lower end estimation range from SW Victoria preparatory activities are being utilised. These costs were provided by AEMO Victorian Planning and are in 2022 dollars. These values will be escalated to 2023 dollars to be applied in the 2024 ISP. Please refer to the IASR workbook for the precise dollar values used.

<ul style="list-style-type: none"> New Mortlake – Bulgana 500 kV double circuit. <p><i>Pre-requisite: Option 1</i> <i>Provided by AEMO (Victoria Planning) – see Section 1.2.</i></p>		Class 5a (± 30%)		
<p>Option 3A:</p> <ul style="list-style-type: none"> New Heywood – Bulgana 500 kV single-circuit New Alcoa Portland – Heywood 500 kV single circuit. <p><i>Pre-requisite: Option 1</i> <i>Provided by AEMO (Victoria Planning) – see Section 1.2.</i></p>	1,800	1,006 Class 5a (± 30%)	271	Long
<p>Option 3B:</p> <ul style="list-style-type: none"> New Heywood – Bulgana 500 kV double-circuit New Alcoa Portland – Heywood 500 kV single circuit. <p><i>Pre-requisite: Option 1</i> <i>Provided by AEMO (Victoria Planning) – see Section 1.2.</i></p>	2,800	1,239 Class 5a (± 30%)	271	Long

Adjustment factors and risk

Option	Adjustment factors applied	Known and unknown risks applied
Option 1	<ul style="list-style-type: none"> Land Use: grazing, developed area Jurisdiction: VIC Project network element size: # of total Bays 1 – 5/100 to 200 km Location (regional/distance factors): Regional Delivery timetable: Long 	<p>Known Risks:</p> <ul style="list-style-type: none"> Outage restrictions: high Environmental offset risks: High Others: BAU <p>Unknown risks: Class 5a</p>
Option 1A	As per Option 1	As per Option 1
Option 1B	As per Option 1	As per Option 1
Option 1C	As per Option 1	As per Option 1
Option 2A	As per Option 1	As per Option 1
Option 2B	As per Option 1	As per Option 1
Option 3A	As per Option 1 except: <ul style="list-style-type: none"> Project network element size: > 200 km 	As per Option 1
Option 3B	As per Option 1 except: <ul style="list-style-type: none"> Project network element size: > 200 km 	As per Option 1

SEVIC1

Summary				
<p>The group constraint SEVIC1 represents the generation build limit applied to V5, V7 REZs and the Tasmania – Victoria Basslink interconnector. Upgrade options associated with this group constraint may be built to improve the generation capacity in South-East Victoria. These augmentations will facilitate generation transmission to Melbourne load centre.</p>				
Existing network capability				
<p>The network capacity available for SEVIC1 is the same for V5 Gippsland and V7 Gippsland Coast.</p> <p>Approximately 6,000 MW of VRE, interconnector flow and output from other generation can be accommodated at the Hazelwood and Loy Yang 500 kV substations. This includes supply from existing generation, V5, V7 and Tasmania – Victoria. This limit does not include the potential for connection of new generation at the Yallourn 220 kV substation. This limit is represented in the SEVIC1 REZ transmission limit equation.</p> <p>AEMO Victorian Transmission Planning is exploring options for increasing this limit, for example through reconfiguring the arrangement of the 220 kV and 500 kV stations to ensure the existing Transmission lines are fully utilised and to support additional capacity.</p>		<p>* Coastal location for Gippsland Offshore connection is expected to be within the dotted box, as per the Victorian offshore wind transmission development & engagement roadmap.</p>		
Augmentation options				
Description	Additional network capacity (MW)	Expected cost (\$ million) & cost classification.	New transmission line easement length (km)	Lead time
<p>Option 1:</p> <ul style="list-style-type: none"> New 220 kV double-circuit from Hazelwood – Yallourn. 4 x 600 MVA power flow controllers (control power flowing through the Hazelwood TS 500/220kV transformers). Substation works to accommodate new Hazelwood – Yallourn transmission lines & power flow controllers. 	1,500	254 Class 5b (± 50%)	14	Medium
<p>Option 2:</p> <ul style="list-style-type: none"> New 500 kV single circuit from Loy Yang – South Morang within the existing easement corridor. 250 MVAr dynamic reactive compensation <p><i>Pre requisite: Option 1</i></p>	1700	947 ¹¹⁹ Class 5b (± 50%)	-	Long
Adjustment factors and risk				
Option	Adjustment factors applied	Known and unknown risks applied		
Option 1	<ul style="list-style-type: none"> Land Use: Grazing Jurisdiction: VIC Project network element size: 10 to 100 km/# of total Bays 1 - 5 Location (regional/distance factors): Regional 	<p>Known Risks:</p> <ul style="list-style-type: none"> Outage restriction : High Project complexity: Partly complex Environmental offset risks: Low 		

¹¹⁹ This cost estimate assumes zero costs for acquiring property and for environmental offsets for the transmission line components, because it is assumed that an existing easement corridor can be used.

	<ul style="list-style-type: none"> • Delivery timetable: Long 	<ul style="list-style-type: none"> • Macroeconomic influence: Heightened uncertainty • Others: BAU <p>Unknown risks: Class 5b</p>
Option 2	<ul style="list-style-type: none"> • Land Use: Grazing • Jurisdiction: VIC • Project network element size: 100 to 200 km/# of total Bays 1 - 5 • Location (regional/distance factors): Regional • Terrain: Mountainous <p>Delivery timetable: Long</p>	<p>As per Option 1 except:</p> <ul style="list-style-type: none"> • Removal of easement/property costs associated with the transmission line scope of works (existing 500 kV easement space utilised).

5 Generation connection costs

This section considers the costs associated with the physical network elements required to connect individual generators to the broader network. These considerations are in addition to the flow path and REZ considerations in the previous sections of this report.

Section 5 outlines:

- Generator connection costs (Section 5.1).
- Treatment of system strength costs for the ISP (Section 5.2).
- Offshore REZ connection costs (Section 5.3).

5.1 Generator connection costs

Connection costs are added to generator costs to account for the transmission infrastructure required to connect a generator within a REZ to a REZ network, and for connection of other generators and storage. The connection costs vary depending on the proximity to transmission assets and the voltage of the network.

Figure 19 illustrates how connection costs are defined in relation to the REZ network expansion costs.

Figure 19 Connection cost representation

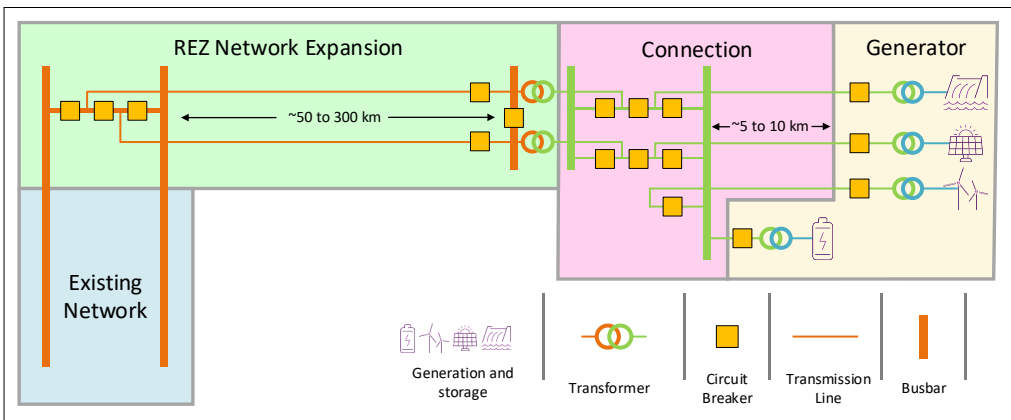

Note: the generator transformation may include more than one step up transformer.

The proximity of the generation to the transmission network is assumed to vary depending on the generator technology. Due to resource location, wind, solar and pumped hydro projects will often be located 5-10 km from the existing network. The connection cost of battery storage is lower than other storage and generation options because battery storage has more flexibility in its location and can leverage the connection assets used in connecting VRE.

Table 9 describes the parameters of the connection assets used for solar and wind generation connecting in each REZ. Table 10 describes parameters for other generation technologies which are close to the network. Table 11 describes parameters for batteries which require no feeder.

Table 9 Connection costs for solar and wind generation technologies

REZ names	Region	REZ network voltage (kV)	Connection capacity (MVA)	Feeder length (km)	Total cost (\$ million)	Cost (\$/kW)
Far North Queensland	QLD	275	300	5	35	116.67
North Queensland Clean Energy Hub	QLD	275	300	10	48	160.00
Northern Queensland	QLD	275	300	5	35	116.67
Isaac	QLD	275	300	5	34	113.33
Barcaldine	QLD	275	300	10	45	150.00
Fitzroy	QLD	275	300	5	34	113.33
Wide Bay	QLD	275	300	5	34	113.33
Darling Downs	QLD	275	300	5	35	116.67
Banana	QLD	275	1,800	100	414	230.00
North West New South Wales	NSW	330	400	10	54	135.00
New England	NSW	330	400	10	54	135.00
Central-West Orana	NSW	330	400	10	54	135.00
Broken Hill	NSW	220	250	10	44	176.00
South West New South Wales	NSW	330	400	10	54	135.00
Wagga Wagga	NSW	330	400	10	54	135.00
Tumut	NSW	330	400	5	40	100.00
Cooma-Monaro	NSW	330	400	5	40	100.00
Hunter-Central Coast	NSW	330	400	10	40	100.00
Hunter Coast	NSW	N/A*	N/A*	N/A*	N/A*	N/A*
Illawarra Coast	NSW	N/A*	N/A*	N/A*	N/A*	N/A*
Illawarra	NSW	330	400	5	40	100.00
Ovens Murray	VIC	220	250	5	34	136.00
Murray River	VIC	220	250	5	33	132.00
Western Victoria	VIC	220	250	5	35	140.00
South West Victoria	VIC	500	600	10	84	140.00
Gippsland	VIC	220	250	10	49	196.00
Central North Victoria	VIC	220	250	10	46	184.00
Gippsland Coast	VIC	N/A*	N/A*	N/A*	N/A*	N/A*
Portland Coast	VIC	N/A*	N/A*	N/A*	N/A*	N/A*
South East South Australia	SA	275	300	10	45	150.00
Riverland	SA	275	300	10	50	166.67
Mid-North South Australia	SA	275	300	5	36	120.00
Yorke Peninsula	SA	275	300	5	36	120.00
Northern South Australia	SA	275	300	5	34	113.33
Leigh Creek	SA	275	300	10	46	153.33
Roxby Downs	SA	275	300	10	44	146.67

REZ names	Region	REZ network voltage (kV)	Connection capacity (MVA)	Feeder length (km)	Total cost (\$ million)	Cost (\$/kW)
Eastern Eyre Peninsula	SA	275	300	10	44	146.67
Western Eyre Peninsula	SA	275	300	10	44	146.67
South East South Australia Coast	SA	275	1,200	50	894	745.00
North East Tasmania	TAS	220	150	5	41	273.33
North West Tasmania	TAS	220	150	5	36	240.00
Central Highlands	TAS	220	150	5	33	220.00
North West Tasmania Coast	TAS	N/A*	N/A*	N/A*	N/A*	N/A*
North East Tasmania Coast	TAS	N/A*	N/A*	N/A*	N/A*	N/A*
Adjustment factors and risk						
All options	<ul style="list-style-type: none"> Location (regional/distance factors): Regional Project network element size: no. of total Bays 1-5 Jurisdiction: unique to REZ location 			<ul style="list-style-type: none"> Known risks: BAU Unknown risks: Class 5 		

* Connection costs already included in the generation cost

Table 10 Connection costs for other generation technologies (excluding batteries)

Connection voltage (kV)	Connection capacity (MVA)	Feeder length (km)	Total cost (\$ million)	Cost (\$/kW)
500	600	1	57	95.00
330	400	1	25	62.50
275	300	1	24	80.00
220	250	1	23	92.00
Adjustment factors and risk				
All options	<ul style="list-style-type: none"> Project network element size: no. of total Bays 1-5, 1 to 5 km 		<ul style="list-style-type: none"> Known risks: BAU Unknown risks: Class 5 	

Note: Connection costs for pumped hydro are included in the generation cost.

Table 11 Connection costs for batteries

Connection voltage (kV)	Connection capacity (MVA)	Total cost (\$ million)	Cost (\$/kW)
500	600	51	85.00
330	400	22	55.00
275	300	21	70.00
220	250	20	80.00
Adjustment factors and risk			
All options	<ul style="list-style-type: none"> Project network element size: no. of total Bays 1-5 		<ul style="list-style-type: none"> Known risks: BAU Unknown risks: Class 5

5.2 System strength costs

The provision of system strength services to facilitate operation of VRE is a complex requirement that is related to system strength available from the broader power system, nearby network upgrades, and the scale of local inverter-based resources (IBR). As such, AEMO applies system strength service costs as a post-processed value in the ISP model rather than modelling this in detail in the power system modelling process.

AEMO will include system strength service cost estimates in the ISP to estimate the requirement to support stable operation of IBR in the NEM, consistent with the system strength standard¹²⁰.

Synchronous condenser costs are used to derive a proxy cost for potential system strength remediation solutions. Costs shown include synchronous condensers, site works and buildings, step up transformers, and high voltage connection assets. The addition of flywheels for high-inertia synchronous condensers incurs an additional \$2 million cost.

Table 12 System strength services cost options

Description	Expected cost (\$ million)	Cost classification	Lead time
80 MVA synchronous condenser	71	Class 5b (±50%)	Medium
125 MVA synchronous condenser	96	Class 5b (±50%)	Medium
200 MVA synchronous condenser	132 ^A	Class 5b (±50%)	Medium
250 MVA synchronous condenser	182	Class 5b (±50%)	Medium
Adjustment factors and risk			
All options	<ul style="list-style-type: none"> Greenfield or Brownfield: Partly Brownfield Location (regional/distance factors): Regional Project network element size: no. of total Bays 1-5 	<ul style="list-style-type: none"> Known risks: Project Complexity was judged as partly complex due to the level of detailed studies required. Unknown risks: Class 5b 	

A. This cost is the result of halving the costs of the 2 x 200 MVA synchronous condenser network element.

5.3 Offshore renewable energy zone design

The ISP model includes offshore REZs to connect offshore generation resources off the coast of Australia to the mainland NEM. AEMO is aware of international projects, either being progressed to commissioning or in service, where offshore generation is connecting to mainland transmission networks using a variety of transmission solutions including HVAC and HVDC assets.

For the ISP, it is important to consider what is already factored in when it comes to generation costs. Figure 20 illustrates the asset inclusion from GenCost and identifies where additional network assets may be required to connect offshore wind to the NEM. The GenCost assumptions for offshore wind include the offshore network assets up to a substation 20 km inland. Additional network assets are required when the existing network assets are further than 20 km from the coast. This additional network is considered a connection asset in the ISP, rather than a REZ expansion option, as it is dedicated to connecting to offshore generation.

¹²⁰ This does not include the minimum fault level requirement element of the system strength standard.

Figure 20 Offshore renewable energy zone design and connection to existing network

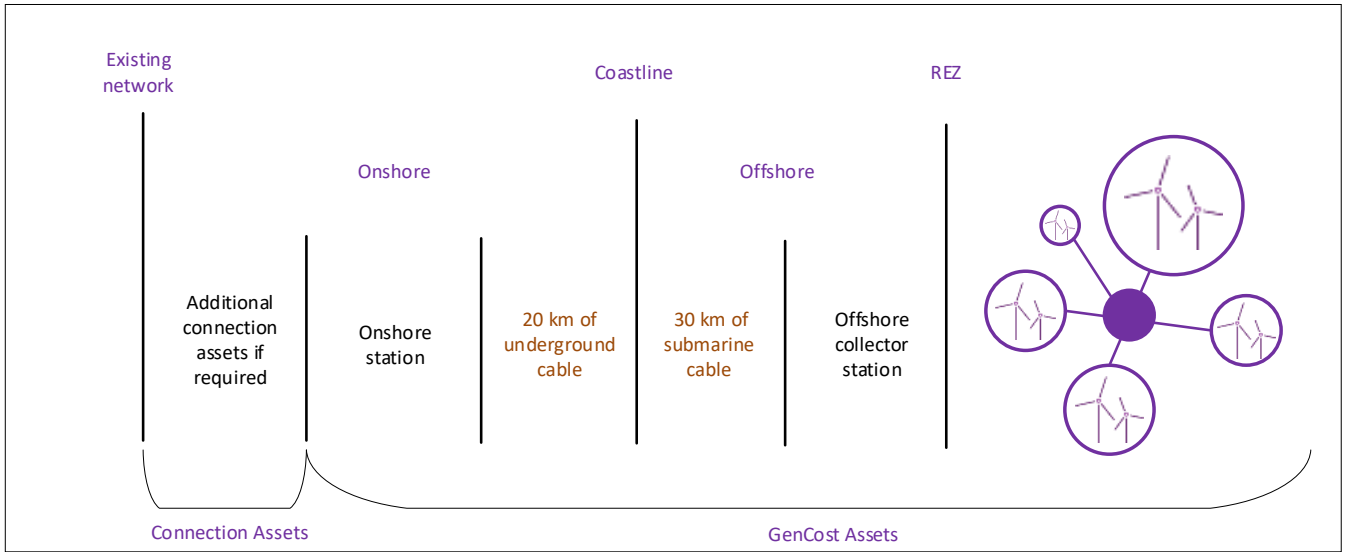

For some offshore REZs, no additional connection assets are required to the existing network. Examples include Portland Coast in Victoria or Illawarra Coast in New South Wales, where the existing network is within 20 km of the coast. As a result, much of the connection cost is already considered in the generation cost and the connection cost for these offshore REZs is zero.

For other coastal REZs, like S10 South East SA Coast and V7 Gippsland Coast in Victoria, existing network is further than 20 km from the coastline and additional connection assets are required to bridge between the offshore generation assets and the existing network or REZ network expansion option. For these REZs, the cost of additional transmission is included either as a connection cost or with augmentation options.

A1. Cost classification checklist

The checklist developed by AEMO for review of the TNSP estimates is shown below.

Class sub-category	Class 5		Class 4	Class 3	Class 2/1
	'b'	'a'			
Scope of works – line, station, cable					
Voltage defined?	Yes	Yes	Yes	Yes	Yes
Rating (MVA, MW, MVA _r) defined?	Yes	Yes	Yes	Yes	Yes
Conductors specified?	Yes	Yes	Yes	Yes	Yes
Connection locations (substation, terminal station, converter) defined?	Yes	Yes	Yes	Yes	Yes
Which option best describes the maturity of the routing?	Preliminary Corridor	Preliminary Corridor	High Level Route	Detailed Route	Detailed Route
Have gas network avoidance measures been included?	No	No	No	Yes	Yes
Which option best describes the consideration of national parks?	None	None	High Level	Detailed	Detailed
Which option best describes the consideration of cultural heritage?	None	High Level	High Level	Detailed	Detailed
Which option best describes the consideration of environmentally sensitive areas?	None	High Level	High Level	Detailed	Detailed
Underground lines defined?	No	No	No	Yes	Yes
Which option best describes the maturity of the design?	Concept/High Level	Concept/High Level	Preliminary	Detailed/Complete	Detailed/Complete
Which option best describes the maturity of the scope?	Concept	Screening	Preliminary	Detailed/Complete	Detailed/Complete
Which option best describes the documentation prepared?	-	Conceptual Single Line Diagram	Detailed Single Line Diagram	For Construction/Civil Diagrams	For Construction/Civil Diagrams
Level of site investigation for stations/substations/converters/terminal stations?	Desktop	Desktop	Desktop	Preliminary Site Investigation	Detailed Investigation
Has site remoteness been incorporated into the scope of works?	Yes	Yes	Yes	Yes	Yes
Which option best describes the geographical location of any stations/substations included?	Assumed	Assumed	General Area Defined	Actual Location Defined	Actual Location Defined
Which option best describes the tower design progress?	Assumption Based	Assumption Based	Preliminary Design	Final Design	Final Design
Sites					
Are there any environmental offsets included based on past experience?	Yes	Yes	Yes	Yes	Yes
Strategy/approach developed to refine environmental offsets complete?	Yes	Yes	Yes	Yes	Yes
Are outage restrictions (specific to line diversions and cut ins) considered?	No	No	No	Yes	Yes
Which option best describes the consideration of brownfield works across the project?	None	None	Indicative	Indicative	Detailed/Complete
Terrain assessment	Desktop	Desktop	Detailed	Detailed	Detailed
Which option best describes the current level of engagement with landowners?	None	None	None	Community Level	Landowner Level

Class sub-category	Class 5		Class 4	Class 3	Class 2/1
	'b'	'a'			
Project management and delivery					
Which option best describes the level of geotech assessment?	None	None	None	Desktop Assessment	Detailed Assessment
Which option best describes the source of cost estimate for equipment and construction?	Previous Projects	Previous Projects	Single In-house Price	Multiple Quotes	Fixed Contract
Which option best describes the identification and assessment of risk progress?	Concept/High Level	Concept/High Level	Preliminary	Preliminary	Detailed/Complete
Has macroeconomic influence been factored into the assessment of risk?	Yes	Yes	Yes	Yes	Yes
Has market activity been factored into the assessment of risk?	Yes	Yes	Yes	Yes	Yes
Has project complexity been factored into the assessment of risk?	Yes	Yes	Yes	Yes	Yes
Has compulsory acquisition been factored into the assessment of risk?	Yes	Yes	Yes	Yes	Yes
Has environmental offset been factored into the assessment of risk?	Yes	Yes	Yes	Yes	Yes
Has geotechnical findings been factored into the assessment of risk?	Yes	Yes	Yes	Yes	Yes
Has outage restrictions been factored into the assessment of risk?	Yes	Yes	Yes	Yes	Yes
Has weather delays been factored into the assessment of risk?	Yes	Yes	Yes	Yes	Yes
Has cultural heritage been factored into the assessment of risk?	Yes	Yes	Yes	Yes	Yes
Has any allowance been made for unknown scope and technology risk?	Yes	Yes	Yes	Yes	Yes
If yes, please indicate allowance amount as a % of baseline cost					
Has any allowance been made for unknown productivity and labour cost risk?	Yes	Yes	Yes	Yes	Yes
If yes, please indicate allowance amount as a % of baseline cost					
Has any allowance been made for unknown plant procurement cost risk?	Yes	Yes	Yes	Yes	Yes
If yes, please indicate allowance amount as a % of baseline cost					
Has any allowance been made for unknown project overhead risk?	Yes	Yes	Yes	Yes	Yes
If yes, please indicate allowance amount as a % of baseline cost					
Which best describes the level of market engagement?	None	None	Revenue Reset/Project Brief	Pre-Tender	Tender
Regulatory					
Scope of works prepared as part of which regulatory gateway?	Future ISP	Future ISP	PADR	CPA	-
Regulatory model	-	Conventional RIT-T	Conventional RIT-T	Conventional RIT-T	Conventional RIT-T