

System Strength Impact Assessment Guidelines

Prepared by: AEMO System Design

Version: 2.0

Effective date: 15 March 2023

Status: **FINAL**

Approved for distribution and use by:

Approved by: Merryn York

Title: Executive General Manager System Design

Date: 15 March 2023

aemo.com.au

New South Wales | Queensland | South Australia | Victoria | Australian Capital Territory | Tasmania | Western Australia

Australian Energy Market Operator Ltd ABN 94 072 010 327

Contents

Current version release details	3
1. Introduction	4
1.1. Purpose and scope	4
1.2. Definitions and interpretation	4
1.3. Related documents	6
2. Application	7
2.1. 4.6.6 Connections	7
2.2. Classification of IBL and IBR	7
2.3. Plant alterations	8
2.4. AEMO's role	9
2.5. Overview of connection/alteration process	9
3. Concepts	13
3.1. General system strength impact	13
3.2. Nature of impacts considered to be general system strength Impacts	13
3.3. Adverse system strength impact	13
3.4. Available fault levels	15
3.5. Materiality Threshold	17
4. System strength impact assessments	18
4.1. Preliminary assessments	18
4.2. Full assessments	20
5. System strength remediation	26
5.1. System strength remediation schemes	26
5.2. System strength connection works	29
6. System strength locational factor	30
6.1. Purpose of SSLF	30
6.2. Timing	31
6.3. Circumstances in which SSLF calculation is not required	31
6.4. Methodology for undertaking SSLF calculation	31
6.5. Circumstances where a revision to SSLF is required	32
6.6. No averaging of SSLFs	32
7. Short circuit ratio	32
7.1. Definition of SCR	32
7.2. SCR access standards	33
7.3. SCR assessment	33
7.4. Withstand SCR assessment	35
7.5. Demonstration of compliance with SCR performance standards	37
7.6. Changes to plant performance	38
8. Stability Assessments	38
8.1. Requirement for Stability Assessment	38
8.2. Timing	39
8.3. Information to be provided by Applicants	39

8.4.	Power system model	39
8.5.	Matters to be considered by the Connecting NSP	39
8.6.	Methodology	39
8.7.	Results to be provided to Applicants	41
8.8.	Timing of provision of results	41
8.9.	Consultation with AEMO	41
8.10.	Consequence of plant instability	41
9.	Identifying committed projects	42
9.1.	Provision of database	42
9.2.	Updates to database	42
APPENDIX A. EXAMPLE OF ΔAFL CALCULATION		43
A.1	Calculation of Δ AFL for 4.6.6 Connections	43
A.2	Calculation of AFL at system busbars	44
APPENDIX B. WITHSTAND SCR TESTS		46
Version release history		48

Tables

Table 1	AFL calculation for the example network	45
Table 2	Minimum set of tests for demonstration of stability [at SCR of 3.0 or lower].....	46
Table 3	Minimum set of tests for impulse and voltage step tests [at SCR of 3.0 or lower]	47
Table 4	Minimum set of tests for impedance change to SCR of 3.0 [or lower]	47

Figures

Figure 1	Facilities that are 4.6.6 Connections	8
Figure 2	Connection process overview.....	10
Figure 3	System strength impact assessment process within connection process.....	12
Figure 4	Test system for example AFL calculation.....	43

Current version release details

Version	Effective date	Summary of changes
2.0	15 March 2023	Amended following the National Electricity Amendment (Efficient management of system strength on the power system) Rule 2021

1. Introduction

1.1. Purpose and scope

These are the *system strength impact assessment guidelines* (**Guidelines**) made under clause 4.6.6 of the National Electricity Rules (**NER**). These Guidelines have effect only for the purposes set out in the NER. The NER and the National Electricity Law prevail over these Guidelines to the extent of any inconsistency.

These Guidelines cover the following matters, as specified in NER 4.6.6(a) and (b):

- A methodology for undertaking *system strength impact assessments*, including a preliminary assessment and a full assessment.
- A methodology for calculating a *system strength locational factor* (**SSLF**).
- A threshold below which a system strength impact may be disregarded for the purposes of NER 5.3.4B(f)(3) (**Materiality Threshold**).
- A definition and guidance on the calculation of *available fault levels* (**AFLs**).
- A methodology for assessing the *short circuit ratio* (**SCR**) for the purposes of the SCR access standards¹.
- Guidance on information to demonstrate compliance with relevant *performance standards*.
- The criteria for classification of a *load* as an *inverter based load* (**IBL**).
- The criteria for classification of an *inverter based resource* (**IBR**) as a *large inverter based resource* (**LIBR**).
- How AEMO assesses *adverse system strength impacts*.
- Guidance on the methodology to be used when undertaking modelling to verify the stability of *plant*.

1.2. Definitions and interpretation

1.2.1. Glossary

Terms defined in the National Electricity Law and the NER have the same meanings in these Guidelines unless otherwise specified in this section 1.2.1. Terms defined in the NER are intended to be identified in these Guidelines by italicising them, but failure to italicise a defined term does not affect its meaning.

In addition, the words, phrases and abbreviations in the table below have the meanings set out opposite them when used in these Guidelines.

Term	Definition
4.6.6 Connection	A proposed <i>connection</i> or alteration described in section 2.1.
4.6.6 Connection Point	The <i>connection point</i> of a 4.6.6 Connection.
AC	Alternating current.
Applicant	A person proposing <i>connection</i> of a 4.6.6 Connection.
AFL	<i>available fault level</i> . See definition in section 3.4.1.

¹ The new *access standards* can be found in NER S5.2.5.15, S5.3.11 and S5.3a.7.

Term	Definition
BESS	Battery energy storage system.
CIGRE TB 671	CIGRE Technical Brochure TB 671 entitled “Connection of Wind Farms to Weak AC Networks.
Committed	In respect of a proposed <i>connection</i> other than the 4.6.6 Connection: <ul style="list-style-type: none"> (a) AEMO has issued a letter to the Connecting NSP under NER 5.3.4A indicating that AEMO is satisfied that all proposed <i>negotiated access standards</i> meet the requirements applicable to the relevant <i>negotiated access standard</i> under the NER; (b) AEMO and the Connecting NSP for that proposed <i>connection</i> have accepted a detailed PSCAD™/EMTDC™ model of that proposed <i>connection</i> provided by or on behalf of the Applicant meets the requirements of the <i>Power System Model Guidelines</i>; (c) any proposed <i>system strength remediation schemes</i> or <i>system strength connection works</i> have been agreed between the relevant parties, or determined by a <i>dispute resolution panel</i>; (d) a <i>connection agreement</i> has been executed in respect of the proposed <i>connection</i>; and (e) there is no reasonable basis to conclude that the model previously provided is materially inaccurate, including following commissioning of the <i>connection</i>.
Connecting NSP	The NSP in receipt of a <i>connection</i> application or alteration proposal for a 4.6.6 Connection.
EMT	Electromagnetic transient.
EMTDC	Electromagnetic transients including DC.
FACTS	Flexible AC <i>transmission system</i> .
FRT	Fault ride-through
Full Assessment	The assessment referred to in NER 4.6.6(b)(1)(ii).
HVDC	High <i>voltage</i> direct current.
IBL	<i>inverter based load</i> .
IBR	<i>inverter based resource</i> .
LIBR	<i>large inverter based resource</i> .
LVRT	Low <i>voltage</i> ride-through
Materiality Threshold	As defined in section 1.1, as determined under section 3.5 where applicable.
MNSP	<i>Market Network Service Provider</i> .
MV	Medium <i>voltage</i> .
MVA	megavolt-ampere.
MW	megawatt.
NER	National Electricity Rules. NER followed by a number indicates the corresponding rule or clause of the NER.
NSP	<i>Network Service Provider</i> .
OEM	Original equipment manufacturer.
OPDMS	AEMO’s Operations and Planning Data Management System.
Other IBR Facility	A 4.6.6 Connection comprised of a <i>facility</i> that includes an IBR and is subject to NER schedule 5.3, as referred to in NER 5.3.4B(a)(2).
Preliminary Assessment	The assessment referred to in NER 4.6.6(b)(1)(i).
PSCAD™/EMTDC™	Power System Computer Aided Simulation. Where this is used in describing a model, it is to be read as referring to a model that meets the Power System Model Guidelines.
PSS®E	Power System Simulator for Engineering. Where this is used in describing a model, it is to be read as referring to a model that meets the Power System Model Guidelines.
RMS	Root mean square.

Term	Definition
SCR	<i>short circuit ratio.</i>
SMIB	Single machine infinite bus.
SSC	<i>system strength charge.</i>
SSCW	<i>system strength connection works.</i>
SSLF	<i>system strength locational factor</i>
SSN	<i>system strength node.</i>
SSQ	<i>system strength quantity.</i> This is an estimate of the magnitude of the <i>general system strength impact</i> of a 4.6.6 Connection.
SSRS	<i>system strength remediation scheme.</i>
SSS	<i>system strength services.</i>
SSSP	<i>System Strength Service Provider.</i>
Stability Assessment	The modelling referred to in NER 5.3.4B(a2)(4).
STATCOM	Static synchronous compensator.
Synchronous Machine	<i>A synchronous generating unit or a synchronous condenser.</i>
Synchronous Three Phase Fault Level	The <i>three phase fault level comprising</i> Synchronous Machines and those grid-forming inverters whose positive system strength contribution has been demonstrated by wide-area PSCAD™/EMTDC™ studies, in MVA.
TNSP	<i>Transmission Network Service Provider.</i>
Withstand SCR	See section 7.2.1.
X/R ratio	The ratio of the system reactance to the system resistance.

1.2.2. Interpretation

The following principles of interpretation apply to these Guidelines unless otherwise expressly indicated:

- these Guidelines are subject to the principles of interpretation set out in Schedule 2 of the National Electricity Law; and
- units of measurement are in accordance with the International System of Units.

1.3. Related documents

Title	Location
Access Standard Assessment Guide	https://aemo.com.au/en/energy-systems/electricity/national-electricity-market-nem/participate-in-the-market/network-connections/transmission-and-distribution-in-the-nem/stage-3-application
Dynamic Model Acceptance Test Guideline	https://aemo.com.au/energy-systems/electricity/national-electricity-market-nem/participate-in-the-market/network-connections/modelling-requirements
Generator Connection Application Checklist	https://aemo.com.au/en/energy-systems/electricity/national-electricity-market-nem/participate-in-the-market/network-connections/transmission-and-distribution-in-the-nem/stage-3-application
Power System Model Guidelines	https://aemo.com.au/energy-systems/electricity/national-electricity-market-nem/participate-in-the-market/network-connections/modelling-requirements
Power System Stability Guidelines	https://aemo.com.au/en/energy-systems/electricity/national-electricity-market-nem/system-operations/congestion-information-resource
System Strength Reports	https://aemo.com.au/en/energy-systems/electricity/national-electricity-market-nem/nem-forecasting-and-planning/planning-for-operability
System Strength Requirements Methodology	https://aemo.com.au/energy-systems/electricity/national-electricity-market-nem/nem-forecasting-and-planning/planning-for-operability

2. Application

2.1. 4.6.6 Connections

These Guidelines apply to *Network Service Providers (NSPs)* who are required to undertake *system strength impact assessments* and calculations of *system strength locational factors (SSLFs)* under NER 5.3.4B (**Connecting NSPs**). Connecting NSPs are required to undertake a *system strength impact assessment* in accordance with these Guidelines where someone (**Applicant**) is proposing:

- (a) *connection of a new generating system² to which NER 5.3 or 5.3A applies, which includes embedded generating units for which there is no automatic exemption from the requirement to register as a Generator and LIBRs³;*
- (b) *connection of a new market network service facility to which NER 5.3 or 5.3A applies;*
- (c) *connection of a new facility of a Network User that includes an IBR, to which NER schedule 5.3 applies (Other IBR Facility);*
- (d) *an alteration to a generating system to which NER 5.3.9(a)(2) applies; or*
- (e) *an alteration to connected plant other than a generating system to which NER 5.3.12 applies.*

These are referred to in these Guidelines as a **4.6.6 Connection**.

2.2. Classification of IBL and IBR

- (a) An LIBR is defined in the NER as an IBR that is classified as an LIBR in accordance with these Guidelines. The NER define an IBR as comprising *asynchronous generating units* and IBL. An IBL is defined as a *load* classified as an IBL in accordance with these Guidelines.
- (b) Figure 1 depicts the relationship between these types of *plant*, and which IBLs and IBRs can be considered to be a 4.6.6 Connection.

² Although the NER refer to *generating systems*, in practice, it is unlikely that *synchronous generating systems* will be required to undergo a Full Assessment or Stability Assessment in accordance with these Guidelines.

³ NER 5.3.1A.

Figure 1 Facilities that are 4.6.6 Connections

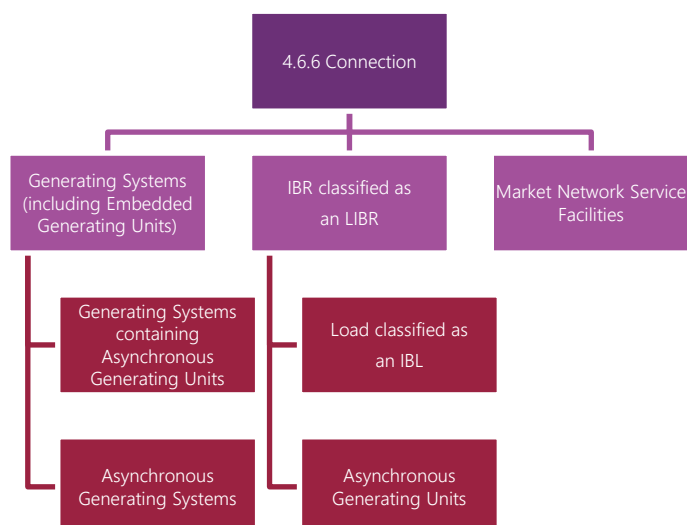

- (c) AEMO is required to specify the criteria for classification of:
- (i) A *load* as an IBL⁴.
 - (ii) An IBR as an LIBR, which must take into account *plant* type and size and other matters AEMO considers relevant to identifying IBR that may have a *general system strength impact* above the Materiality Threshold⁵.
- (d) AEMO considers that the size of a *load* or IBR should be determinative of the need for a *system strength impact assessment*. Hence, the key criterion for classifying *load* as an IBL or an IBR as an LIBR is a minimum capacity of 5 MW or 5 MVA.
- (e) For clarity, it is noted that a *load* can only be an IBL if it also meets the criteria inherent in the NER definition of *inverter based load* itself. That is, the load must be:
- (i) supplied by power electronics, including inverters; and
 - (ii) potentially susceptible to inverter control instability.

2.3. Plant alterations⁶

2.3.1. Generating system alterations under NER 5.3.9

- (a) A proposed alteration to a *generating system* under NER must include the Applicant's proposed SSRS or an election to pay the *system strength charge (SSC)* 'where relevant'. This is taken to refer to the criterion in NER 5.3.9(a)(2), i.e. 'in AEMO's reasonable opinion, [the alteration will] have a general system strength impact'.
- (b) Given this criterion, the Applicant or the Connecting NSP must request AEMO's opinion on the potential impact of a proposed *generating system* alteration before making any formal submission under NER 5.3.9(b).

⁴ See NER 4.6.6(a)(5).

⁵ See NER 4.6.6(a)(6).

⁶ See also NER 11.143.11.

- (c) If in AEMO's opinion the proposed alteration will have a *general system strength impact*, a Preliminary Assessment should be requested to inform the Applicant's submission under NER 5.3.9(b) of a proposed SSRS or election to pay the SSC.
- (d) If in AEMO's opinion the proposed alteration will not have a *general system strength impact*, the alteration is not a 4.6.6 Connection.

2.3.2. Alterations to other plant under NER 5.3.12

- (a) For a proposed alteration to *connected plant* other than a *generating system*, NER 5.3.12 only applies if the proposed alteration will affect the *plant's* performance relative to the technical requirements under NER S5.3.11 or S5.3a.7 (that is, its Withstand SCR capability).
- (b) If the proposed alteration is expected to affect Withstand SCR performance, a Preliminary Assessment should be requested to inform the Applicant's submission under NER 5.3.12(b) of a proposed SSRS or election to pay the SSC.
- (c) If the proposed alteration is not expected to affect Withstand SCR performance (which should be confirmed in consultation with the Connecting NSP and, where appropriate, AEMO), NER 5.3.12 does not apply and the alteration is not a 4.6.6 Connection.

2.4. AEMO's role

- (a) AEMO is involved in the *connection* application process in two capacities:
 - (i) As *power system* operator.
 - (ii) As *transmission network* planner in Victoria.
- (b) References to AEMO in these Guidelines concern AEMO's functions as *power system* operator. References to a Connecting NSP include, in the context of the *transmission network* in Victoria, AEMO in its capacity as *transmission network* planner in Victoria.

2.5. Overview of connection/alteration process

AEMO provides extensive information on its website⁷ about AEMO's involvement, in conjunction with Connecting NSPs, in the process for *connection* and alteration of relevant *plant*. The information in this section 2.5 is provided only for context, to assist in understanding how the *system strength impact assessment* interacts with other elements of a connection/alteration of a 4.6.6 Connection.

2.5.1. New plant

- (a) The process by which *plant* that is proposed to be *connected* to a *transmission network* or *distribution network* is envisaged by the NER as essentially sequential, as shown in Figure 2⁸.

⁷ See <https://aemo.com.au/en/energy-systems/electricity/national-electricity-market-nem/participate-in-the-market/network-connections>.

⁸ See rule 5.3 and rule 5.3A of the NER.

Figure 2 Connection process overview

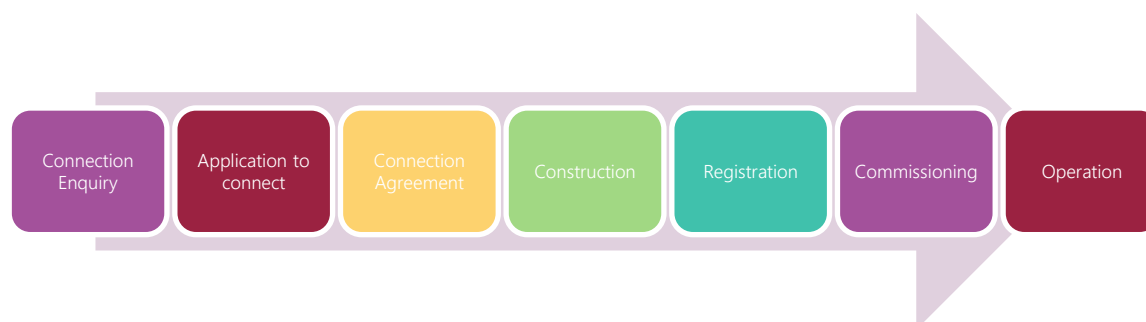

- (b) From a NER perspective, the process commences when a *Connection Applicant* submits a *connection enquiry* to the NSP for the *network* to which the *Connection Applicant* wishes to connect their *plant*. There is an exchange of information between the *Connection Applicant* and the NSP. The information that the NSP must provide to the *Connection Applicant* is designed to assist the *Connection Applicant* in determining the feasibility of their proposed *connection* and whether to submit an *application to connect*.
- (c) When a *Connection Applicant* submits an *application to connect*, the Connecting NSP and AEMO (with respect to *AEMO advisory matters*) commence a technical due diligence of the proposed *connection* using the substantial amount of technical information the *Connection Applicant* is required to submit along with its *application to connect*.
- (d) If the *Connection Applicant* and the *Connecting NSP* reach agreement as to the technical and commercial terms of the proposed *connection*, they will enter into a *connection agreement*, which incorporates the technical requirements and *performance standards* to apply to the *connection* once it is constructed and commissioned, as well as the agreed arrangements to address any assessed *general system strength impact* of the *connection*.
- (e) Commissioning and commercial operation of the new *connection* depends on the Connecting NSP and AEMO's approval under NER 5.8 and is conditional upon AEMO's approval of the *Connection Applicant's* application for registration under NER Chapter 2.

2.5.2. Alterations to plant

- (a) Proposed alterations to certain types of *plant* that is subject to NER Chapter 5 technical requirements are regulated by NER 5.3.9 and 5.3.12. A relevant *Generator*, *Network User* or *Market Network Service Provider* to submit its proposal to the Connecting NSP and AEMO where the proposed alteration will have certain impacts on the *plant's* performance relative to technical requirements in the relevant NER Chapter 5 schedule or on system strength, as specified in those clauses.
- (b) Proposed alterations that are regulated under these NER processes cannot be commissioned unless the Connecting NSP and AEMO are satisfied as to certain technical matters⁹.

⁹ See NER 5.3.10 (alterations to *generating systems*) and NER 5.3.13 (alterations to other *connected plant*).

2.5.3. Integration of system strength impact assessment and connection or alteration processes

- (a) *System strength impact assessments* are part of the broader assessment and approval process for 4.6.6 Connections (both new *connections* and relevant *plant* alterations).
- (b) The *system strength impact assessment* process for new *connections* is shown in Figure 3. The orange boxes in the flowchart show actions and decisions made by an Applicant, while the blue boxes show actions and decisions made by a Connecting NSP. In order to incorporate all substantive steps, please note that the figure does not represent outcomes of a Preliminary Assessment or a Full Assessment that indicate the 4.6.6 Connection has no *general system strength impact*. For clarity, at that point the *system strength impact assessment* process is at an end.
- (c) Alterations to *plant* initiated under NER 5.3.9 or 5.3.12 do not follow the same NER connections process as new *plant*, but their system strength impact is also assessed under NER 5.3.4B. For these purposes, where a proposed alteration to *plant* is a 4.6.6 Connection (refer to section 2.3):
 - (i) the Applicant should request a Preliminary Assessment¹⁰ prior to making a formal submission under NER 5.3.9(b) or NER 5.3.12(b) as part of initial discussions with its Connected NSP, which can be considered comparable to a *connection* enquiry as shown in Figure 3; and
 - (ii) the Applicant's submission under NER 5.3.9(b) or NER 5.3.12(b) is equivalent to an *application to connect*¹¹, therefore the *system strength impact assessment* to be carried out by a Connecting NSP following receipt of that submission must be a Full Assessment or a Stability Assessment, as applicable, as shown in Figure 3.

¹⁰ The Applicant is entitled to request a preliminary assessment under NER 5.3.9(c1) or 5.3.12(d), as applicable.

¹¹ As the submission must either propose an SSRS or state its election to pay the SSC.

Figure 3 System strength impact assessment process within connection process

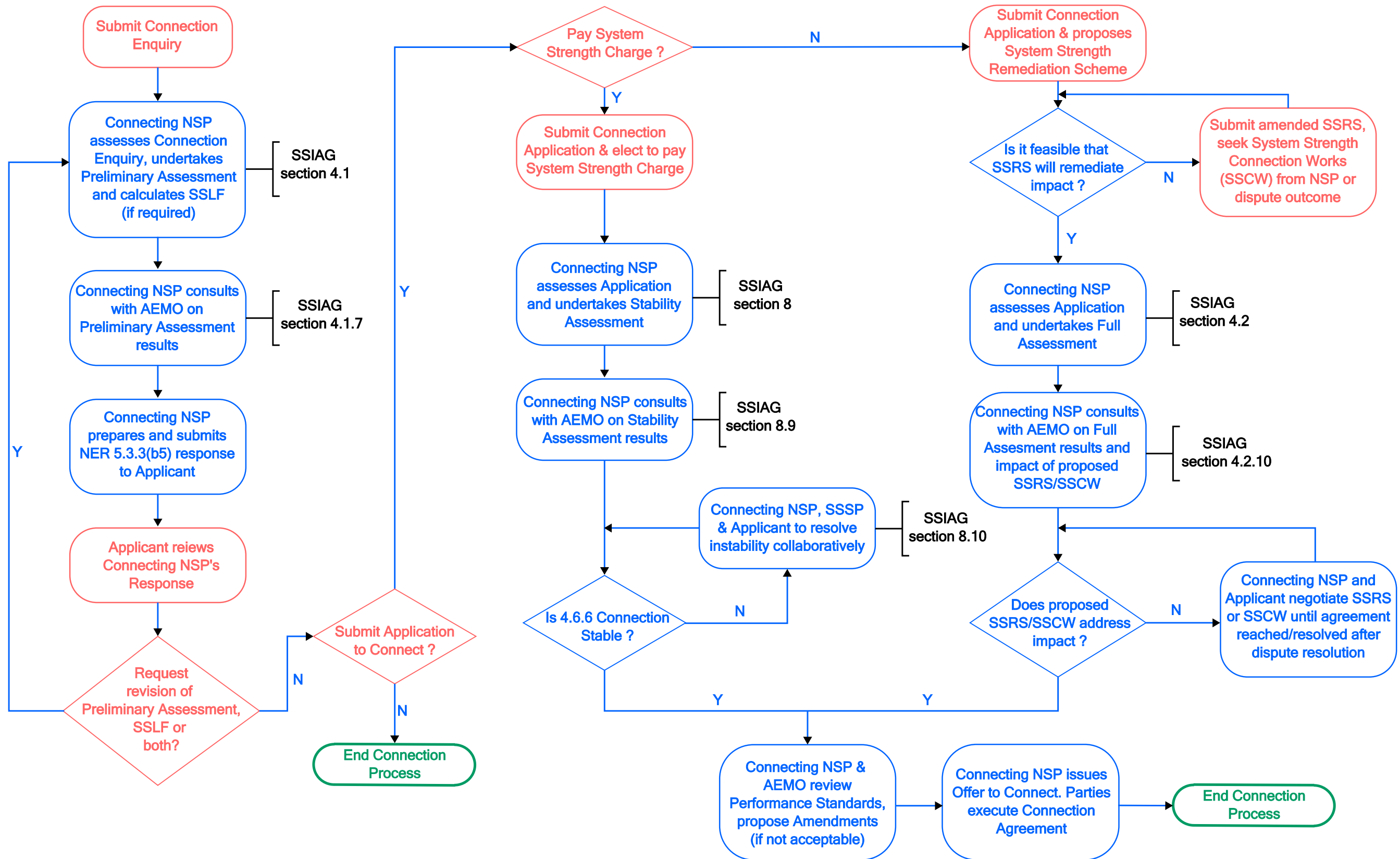

3. Concepts

3.1. General system strength impact

A *general system strength impact* is defined in the NER as follows:

In relation to a new *connection* or an alteration to a *generating system* or other *connected plant*, the amount equal to its *adverse system strength impact* as well as any additional amount by which it reduces the *available fault level* at the *connection point* for the new *connection* or *connected plant*, assessed in accordance with the *system strength impact assessment guidelines*.

3.2. Nature of impacts considered to be general system strength Impacts

These Guidelines must specify the nature of the impacts that AEMO considers to be *general system strength impacts*¹². A *general system strength impact* can be either one or both of:

- (a) An *adverse system strength impact*¹³.
- (b) A reduction in AFL at a 4.6.6 Connection Point¹⁴.

3.3. Adverse system strength impact

3.3.1. Definition

- (a) The NER¹⁵ define an *adverse system strength impact* as follows:

An adverse impact, assessed in accordance with the *system strength impact assessment guidelines*, on the ability under different operating conditions of:

- (a) the *power system* to maintain system stability in accordance with clause S5.1a.3; or
- (b) a *generating system*, or *market network service facility* or *inverter based load* forming part of the *power system* to maintain stable operation including following any *credible contingency event* or *protected event*,

so as to maintain the *power system* in a *secure operating state*.

- (b) AEMO interprets this as follows:

- (i) There is no *adverse system strength impact* if the *power system* can be operated in a *secure operating state* under all operating conditions (in other words, under system normal and following any *credible contingency event* or *protected event*) following *connection* of a 4.6.6 Connection.
- (ii) If the *power system* cannot be maintained in a *secure operating state* following *connection* of a 4.6.6 Connection, an *adverse system strength impact* will occur if:
 - (A) the *power system* cannot maintain system stability in accordance with NER S5.1a.3; **or**
 - (B) the 4.6.6 Connection cannot maintain stable operation.

¹² See NER 4.6.6(b)(5).

¹³ See section 3.3 for further information.

¹⁴ See section 3.4 for further information.

¹⁵ See Chapter 10.

3.3.2. How AEMO assesses adverse system strength impacts

- (a) In considering how to assess *adverse system strength impacts*, the following underlying requirements and consideration for secure and stable *power system* operation are particularly relevant:
- (i) NER S5.1a.3 requires the *power system* to remain in synchronism and be stable in terms of its transient stability, oscillatory stability, and *voltage* stability. It also provides guidance on the circumstances in which stability should be maintained, including following *credible contingency events* and *protected events* and the halving times for oscillations.
 - (ii) Traditionally, *power system* stability adverse impacts are caused by large disturbances associated with contingencies, but an adverse impact can also occur following small disturbances. Additionally, instabilities could arise without any disturbance such as, for example, those caused by the adverse interaction of *control systems* associated with *generating systems* and *network elements*.
 - (iii) Adverse power quality interactions and *control system* instabilities caused by 4.6.6 Connections can cause a breach of NSP *power system* stability obligations across the NEM. For this reason, when assessing a 4.6.6 Connection, AEMO also considers whether the 4.6.6 Connection would give rise to instabilities other than those caused by contingencies, including those solely due to a *control system* stability adverse impact.
- (b) AEMO takes the following into account when undertaking *adverse system strength impact* assessments:
- (i) *networks, generating units*, devices known to be providing system strength support and other *plant*;
 - (ii) Committed projects for new *generating units, generating systems, market network service facilities* and *loads* that include LIBR;
 - (iii) *considered projects*;
 - (iv) variations in *generation* and *load* profiles, including operating conditions at maximum and minimum *loads*, including under minimum *synchronous generation* conditions;
 - (v) AC and HVDC *interconnector* flows including (evaluation of) applicable *constraint* limitations;
 - (vi) *constraints*, limit equations and updates of these provided to AEMO by NSPs;
 - (vii) *credible contingency events* and other events set out in proposed *performance standards*;
 - (viii) operation and impact of, and on, special protection schemes;
 - (ix) *protected events* and *constraints* that apply during those *protected events*; and
 - (x) any other matters that AEMO considers reasonable to include in the circumstances and conditions applicable to the relevant 4.6.6 Connection.

3.3.3. Determining plant stability

An *adverse system strength impact* will occur if a 4.6.6 Connection cannot maintain stability. This section 3.3.3 describes how *plant stability* is to be determined for each type of *plant* comprised in a 4.6.6 Connection.

- (a) The stable operation of a *generating system* is determined by reference to whether it can meet its *performance standards* at any level of megawatt (**MW**) output.
- (b) The stable operation of a *market network service facility* is determined by reference to whether it can meet its *performance standards*.
- (c) The stable operation of a *facility* that includes an IBR is determined by reference to whether it can meet its *performance standards*.
- (d) If the IBR includes *asynchronous generating units*, their stable operation is determined by reference to whether they can meet their *performance standards* at any level of MW output.

3.4. Available fault levels

Section 3.4 defines AFLs (section 3.4.1), and provides guidance on the calculation of AFLs separately for the purpose of calculating the SSLF for a 4.6.6 Connection Point (section 3.4.2), and for the purposes of forecasts of AFL at SSNs under NER 5.20C.3(f)(3) (section 3.4.3)¹⁶.

3.4.1. Definition

AFL is used as a proxy to quantify the indicative impact of IBR on the *power system*. It does not represent the fault current observed in the *power system*.

3.4.2. Calculating reduction in AFL at 4.6.6 Connection Point

To calculate the reduction in AFL at a 4.6.6 Connection Point, AEMO adopts a modified version of the methodology published in CIGRE Technical Brochure TB 671 entitled “Connection of Wind Farms to Weak AC Networks”¹⁷. For the purpose of *system strength impact assessments*, the following formula is used to calculate the reduction in AFL:

$$\begin{aligned}\Delta\text{AFL}(MVA) &= -\text{SSQ} + \alpha \times P_{\text{rated}} \\ &= (-\text{SCR}_{\text{withstand}} \times P_{\text{rated}}) + \alpha \times P_{\text{rated}} \\ &= (-\text{SCR}_{\text{withstand}} + \alpha) \times P_{\text{rated}}\end{aligned}$$

Where:

SSQ = as defined in NER 6A.23.5(j), except that the reference to SCR is to be interpreted as the Withstand SCR.

¹⁶ See NER 4.6.6(a)(2).

¹⁷ The AFL does not indicate the actual fault current of an IBR, so it must not be used to indicate performance in *protection system* gradings, primary equipment current rating adequacies or fault current breaking capacities. Furthermore, in choosing this methodology, AEMO is cognizant of the statement on page 153 of AEMC, Efficient management of system strength on the power system, Rule determination, 21 October 2021 that the magnitude of general system strength impact is equivalent to the SSQ, and on page 167 where the AEMC is more specific, in stating that the amount of available fault current by which a 4.6.6 Connection reduces at the 4.6.6 Connection Point would be equivalent to the SSQ.

- $SCR_{\text{withstand}}$ = is assumed to be 3.0 if there is no model of the 4.6.6 Connection available. If a model is available, the proposed Withstand SCR is to be used.
- P_{rated} = *rated active power, rated power transfer capability or maximum demand for the system strength connection point.*
- α = Stability coefficient¹⁸ which is a constant value of 1.2, reflecting assumed limitations in the *network* immediately beyond the 4.6.6 Connection^{19,20}.

3.4.3. Calculation of AFL for the purpose of forecasts at SSNs

For the purpose of forecasting the AFL at each SSN within their *networks* over the period for which AEMO has determined *system strength requirements*²¹, SSSPs must use the following methodology to calculate AFL:

- (a) Step 1: Apply a *power system* topology and configuration consistent with the *system strength requirements methodology* and the outcomes of the most recent *System Strength Report*.
- (b) Step 2: Calculate the Synchronous Three Phase Fault Level at each SSN:
 - (i) Set up the *power system* for the *region* in which the SSSP's *network* is situated, to reflect the SSSP's understanding of which Synchronous Machines will be providing system strength over a 10-year horizon, which:
 - (A) may include *market* modelling outputs provided by AEMO from any assessments undertaken to complete the latest System Strength Report, or anticipated *system strength services (SSS)* to be provided by the SSSP²²; and
 - (B) includes taking *generating systems* and IBLs out of service where they are not expected to provide system strength.
 - (ii) Calculate the *three phase fault level* at each SSN. This is the Synchronous Three Phase Fault Level at the SSN.
- (c) Step 3: Calculate the total *three phase fault level* at each SSN:
 - (i) Set up the *power system* for the *region* in which the SSSP's *network* is situated, to be consistent with Step 1:
 - (A) This includes keeping all *generating systems* and IBLs in service.
 - (B) IBL *generating systems* are to be represented by a Thevenin *voltage* source behind their proxy impedance. This proxy impedance is calculated as the

¹⁸ The stability co-efficient is given a value of 1.2 because technical literature^{21,22} indicates that the minimum SCR for which voltage stability can be maintained in the power system without additional system strength or reactive power support is approximately 1.2. A review of existing NEM connections found that 1.2 also corresponds to approximately the lowest SCR withstand capability for grid-following inverters.

¹⁹ B. Badrzadeh, Z. Emin, S. Goyal, S. Grogan, A. Haddadi, A. Haley, A. Louis, T. Lund, J. Matevosyan, T. Morton, D. Premm, S. Sproul, "System Strength", CIGRE Science and Engineering Journal, Vol. 21, February 2021.

²⁰ T. Lund, H. Wu, H. Soltani, J. G. Nielsen, G. K. Andersen and X. Wang, "Operating Wind Power Plants Under Weak Grid Conditions Considering Voltage Stability Constraints," in IEEE Transactions on Power Electronics, vol. 37, no. 12, pp. 15482-15492, Dec. 2022

²¹ See NER 5.20C.3(f)(3). The period is, effectively, for the next 10 years.

²² Joint planning with adjoining SSSPs and AEMO must ensure that impacts between *regions* are appropriately considered.

inverse (negative) of the $\Delta AFL(MVA)$ quantity. (see illustration in Appendix A).

- (ii) Calculate the *three phase fault level* at each SSN. This is the total *three phase fault level* at the SSN.
- (d) Step 4: Subtract the fault levels calculated in Step 3 and Step 2. This is the delta coefficient (Δ).
- (e) Step 5: Subtract the Δ calculated in Step 4 from the Synchronous Three Phase Fault Level calculated in Step 2. This is the AFL at the SSN.

3.4.4. Example calculations

Examples of the calculation of AFL, ΔAFL at 4.6.6 Connection Points and at an SSN are provided in Appendix A.

3.5. Materiality Threshold

- (a) For the purposes of NER 5.3.4B(f)(3)²³, and subject to paragraphs (b) and (c), a *general system strength impact* of a 4.6.6 Connection may be disregarded if either:
 - (i) the Preliminary Assessment determines that the SSLF cannot be reasonably calculated or would be manifestly excessive; or
 - (ii) the Preliminary Assessment or (where this cannot be determined with confidence in the Preliminary Assessment) the Full Assessment determines that the result of the following calculation (expressed as a percentage) is less than 5%:

$$\frac{\Delta AFL}{Existing AFL}$$

where:

ΔAFL is the reduction in AFL at the 4.6.6 Connection Point, determined under section 3.4.2; and

Existing AFL is the AFL at the 4.6.6 Connection Point prior to the 4.6.6 Connection.

- (b) If either of the conditions in paragraph (a) is met, a *general system strength impact* may only be disregarded if the Preliminary Assessment or (where this cannot be determined with confidence in the Preliminary Assessment) the Full Assessment demonstrates that the 4.6.6 Connection has no *adverse system strength impact*.
- (c) If the condition in paragraph (a)(ii) is met, a *general system strength impact* may only be disregarded if the Connecting NSP is satisfied the *general system strength impact* of the 4.6.6 Connection (by itself or combined with other anticipated *connections* or alterations) is not otherwise material, having regard to all relevant circumstances.²⁴

²³ See NER 4.6.6(b)(7). Any relevant Materiality Threshold is to be considered under NER 5.3.4B(a2)(3)(i) and 5.3.4B(e).

²⁴ Without limiting the circumstances that may be relevant, examples could include the existing system strength in the local network, the level of confidence in models used for assessment, or the number and size of anticipated connections or other potential impacts in the surrounding network.

4. System strength impact assessments

These Guidelines set out a methodology that Connecting NSPs must use when undertaking a *system strength impact assessment*²⁵ for a 4.6.6 Connection. *System strength impact assessments* comprise a two-stage assessment process²⁶ – a Preliminary Assessment and, where required by the NER, a Full Assessment.

4.1. Preliminary assessments

4.1.1. Timing

While the NER are not specific as to when a Preliminary Assessment must commence, there are requirements governing when the results of a Preliminary Assessment must be provided to an Applicant²⁷, which suggest that a Preliminary Assessment is to commence:

- (a) for 4.6.6 Connections comprising new *plant*, upon receipt of a *connection* enquiry²⁸;
- (b) for 4.6.6 Connections comprising alterations to a *generating system*²⁹, or other *connected plant*³⁰, upon receipt of a request for a Preliminary Assessment under NER 5.3.9(c1) or 5.3.12(d); and
- (c) if applicable, upon receipt of a request by an Applicant under NER 5.3.4B(a4) to undertake a further Preliminary Assessment and provide a revised SSLF.

4.1.2. Purpose

The purpose of a Preliminary Assessment is to determine whether the 4.6.6 Connection will cause a *general system strength impact*³¹. In technical terms, its purpose is to:

- (a) provisionally assess the Withstand SCR³² capability of the 4.6.6 Connection;
- (b) calculate the *general system strength impact* by reference to the reduction in AFL³³, which will enable the Applicant to develop an appropriate *system strength remediation scheme (SSRS)* if the Applicant wishes to remediate it, or pay the Connecting NSP to remediate it through SSCW; and
- (c) calculate the SSLF³⁴, which enables the Applicant to estimate the SSC, which will assist the Applicant to determine whether to remediate the *general system strength impact*

²⁵ See NER 4.6.6(a)(1). NER (1)(b) sets out the specific requirements for the methodology.

²⁶ See NER 4.6.6(1)(b)(1).

²⁷ See section 4.1.5.

²⁸ See NER 5.3.3 and 5.3A.8.

²⁹ See NER 5.3.9(b) and (c1).

³⁰ See NER 5.3.12(b) and (d).

³¹ Although NER 4.6.6(b)(1)(i) states its purpose is to screen for the need for a Full Assessment, the need for a Full Assessment is determined by NER 5.4.3B(a2)(3).

³² See section 7.2 for the definition of Withstand SCR.

³³ See section 3.4.2 for further details on the AFL calculation methodology.

³⁴ See section 6 for further details on the SSLF calculation methodology.

(using SSRS or SSCW) or pay the SSC so that the Connecting NSP procures remediation from the relevant *System Strength Service Provider (SSSP)*.

4.1.3. Information to be provided by Applicants

NER 4.6.6(b)(1A) requires the Preliminary Assessment to be carried out using a simple isolated model, such as a single machine infinite bus (**SMIB**) model, but this can only be carried out where site-specific PSCAD™/EMTDC™ and PSS@E models of the 4.6.6 Connection are available.

As these models are unlikely to be available at the *connection* enquiry stage for most new *connections*, but would generally be expected for proposed alterations, AEMO provides two sets of guidelines as to the information required, depending on model availability.

- (a) If site-specific PSCAD™/EMTDC™ and PSS@E models of a 4.6.6 Connection are available, Applicants must provide the Connecting NSP with those models.
- (b) Where there is no site-specific PSCAD™/EMTDC™ and PSS@E model of a 4.6.6 Connection, Applicants must provide the Connecting NSP with the following information about the 4.6.6 Connection to facilitate the Preliminary Assessment³⁵:
 - (i) proposed capacity; and
 - (ii) type of technology to be used.

4.1.4. Matters to be considered by the Connecting NSP

When determining whether a 4.6.6 Connection will result in a *general system strength impact*³⁶, the Connecting NSP must exclude the impact on any *protection system* for a transmission network or distribution network³⁷.

4.1.5. Methodology

Guidance on the methodology to be used by Connecting NSPs when undertaking a Preliminary Assessment of a 4.6.6 Connection is provided in this section 4.1.5, depending on the availability of models³⁸.

- (a) If site-specific PSCAD™/EMTDC™ and PSS@E models of the 4.6.6 Connection are available, the Connecting NSP must undertake the Preliminary Assessment by following the methodology for Withstand SCR assessment described in section 7.4.3³⁹ and then estimate the reduction in AFL in accordance with section 3.4.2.
- (b) If there is no model of the 4.6.6 Connection, the Connecting NSP must estimate the reduction in AFL in accordance with section 3.4.2 and assume the Withstand SCR capability is 3.0.

³⁵ This information is usually required for the *application to connect*, or submission for a proposed alteration.

³⁶ See NER 4.6.6(b)(6).

³⁷ See NER 4.6.6(b)(3).

³⁸ See NER 4.6.6(a)(1).

³⁹ To facilitate the Preliminary Assessment, an Applicant may carry out their own Withstand SCR modelling and provide the results to the Connecting NSP with the models.

4.1.6. Results to be provided to Applicants

A Connecting NSP is required to provide an Applicant with all of the following⁴⁰:

- (a) the minimum *three phase fault level* at the 4.6.6 Connection Point;
- (b) results of the Preliminary Assessment; and
- (c) except where the Connecting NSP is not required to calculate the SSLF⁴¹:
 - (i) the indicative SSQ for the 4.6.6 Connection Point⁴²;
 - (ii) the SSLF for the 4.6.6 Connection Point⁴³; and
 - (iii) the relevant *system strength node (SSN)*⁴⁴ and the indicative SSC using the then applicable *system strength unit price*,

and, where applicable to a *connection* enquiry, this information must be provided within the timeframes specified in NER 5.3.3(b1).

4.1.7. Consultation with AEMO

Prior to providing the results referred to in section 4.1.6 to the Applicant, the Connecting NSP must consult with AEMO⁴⁵ as follows:

- (a) The Connecting NSP is to provide AEMO with the indicative SSQ for the 4.6.6 Connection Point no later than 5 *business days* prior to the date by which the Connecting NSP is required to provide them to the Applicant, together with a list of the assumptions used in the assessment.
- (b) AEMO will respond to the Connecting NSP within 3 *business days* with any concerns, and in the absence of a response the Connecting NSP, may assume that AEMO has no concerns and may provide the required response to the Applicant.
- (c) The Connecting NSP must forward the required information to AEMO at nem.connections@aemo.com.au.

4.2. Full assessments

4.2.1. Timing

Where a Full Assessment is required (see section 4.2.2), and provided all information required by section 4.2.3 is provided to a Connecting NSP, a Full Assessment must commence upon receipt of an *application to connect* or a submission under NER 5.3.9(b) or 5.3.12(b), as applicable.

⁴⁰ See NER 5.3.3(b5).

⁴¹ Because it cannot be calculated, or is manifestly excessive. See NER 5.3.4B(a3) and section 6.3.

⁴² See NER 6A.23.5(j).

⁴³ Calculated in accordance with section 6.4.

⁴⁴ Published by AEMO as part of its System Strength Report, at <https://aemo.com.au/en/energy-systems/electricity/national-electricity-market-nem/nem-forecasting-and-planning/planning-for-operability>.

⁴⁵ See NER 5.3.4B(b).

4.2.2. Purpose

- (a) A Connecting NSP must undertake a Full Assessment of a 4.6.6 Connection following completion of a Preliminary Assessment unless⁴⁶:
 - (i) the Preliminary Assessment indicates there will be no *general system strength impact*⁴⁷; or
 - (ii) the Applicant has elected (in its *application to connect* or submission) to pay the SSC⁴⁸.
- (b) Where a *general system strength impact* was indicated in the Preliminary Assessment for a 4.6.6 Connection, and the Applicant does not elect to pay the SSC, the purpose of the Full Assessment is to:
 - (i) confirm the *general system strength impact* using more detailed modelling; and
 - (ii) if the Applicant has included a proposed SSRS in its application or submission, assess whether the proposed SSRS or any agreed modifications will remedy or avoid the *general system strength impact*; or
 - (iii) if no SSRS is proposed, or an SSRS will not remedy or avoid the *general system strength impact*, determine the scope of SSCW to be undertaken by the Connecting NSP at the Applicant's cost under NER 5.3.4B(e).

4.2.3. Information to be provided by Applicants

To facilitate a Full Assessment, Applicants must provide all the information specified in the Generator Connection Application Checklist⁴⁹ with their *application to connect*.

4.2.4. Power system model

- (a) Full Assessments must be carried out using a *power system* model that is reasonably appropriate for conducting *system strength impact assessments* and applicable to the location in the *transmission network* or *distribution network* at which the 4.6.6 Connection is or may be *connected* and as specified by AEMO⁵⁰.
- (b) Connecting NSPs will require (as a minimum) an appropriate, site-specific PSCAD™/EMTDC™ simulation model of the entire 4.6.6 Connection and suitable models of the surrounding *network*, and *generating systems* and other *plant* either *connected* to the *network* or Committed that could have an impact on the 4.6.6 Connection and on which the 4.6.6 Connection could have an impact.
- (c) For the purposes of paragraph (b) the models used by Connecting NSPs:

⁴⁶ See NER 5.3.4B(a2)(3).

⁴⁷ For clarity, although no further *system strength impact assessment* is required in these circumstances, it is noted that the Connecting NSP or AEMO may need to undertake wide area PSCAD™/EMTDC™ studies for other purposes associated with a 4.6.6 Connection, including the assessment of proposed *negotiated access standards*.

⁴⁸ See NER 5.3.4B(b1).

⁴⁹ At <https://aemo.com.au/en/energy-systems/electricity/national-electricity-market-nem/participate-in-the-market/network-connections/transmission-and-distribution-in-the-nem/stage-3-application>. AEMO has not developed checklists for other types of application, but will do so in time.

⁵⁰ See NER 4.6.6(b)(2).

- (i) must include SSS that would otherwise apply to the *network* under consideration;
- (ii) must include electrically close *connected plant* and Committed *plant*, and
- (iii) may include, where the Connecting NSP considers it practicable and appropriate, electrically close proposed *plant* that is not yet Committed, but for which AEMO has issued a letter to the Connecting NSP under NER 5.3.4A indicating that AEMO is satisfied that all each specified proposed *negotiated access standards* meets the requirements applicable to the relevant standard under the NER,

and *plant* included under sub-paragraph (ii) or (iii) is to be considered regardless of whether Applicants have installed or will be installing SSRs or relying on the provision of SSS from an SSSP.

4.2.5. Matters to be considered by the Connecting NSP

This section 4.2.5 provides guidance about the different *network* conditions and *dispatch* patterns and other relevant matters that must be examined when undertaking a Full Assessment⁵¹.

- (a) To be consistent with the definition of a *general system strength impact*, Connecting NSPs' studies must analyse the *network* under 'system normal' conditions and conditions during and following any *credible contingency event* or *protected event* following the *connection* of a 4.6.6 Connection.
- (b) Because adverse power quality interactions and *control system* instabilities caused by 4.6.6 Connections can cause a Connecting NSP to breach NER S5.1a.3, the Connecting NSP must also consider whether the 4.6.6 Connection would give rise to instabilities other than those caused by contingencies, including those solely due to a *control system* stability adverse impact.
- (c) In its consideration, as a minimum, Connecting NSPs must take into account the following:
 - (i) *networks*, *generating units*, and other *plant* and devices known to be providing system strength support;
 - (ii) Committed projects for new *generating units*, *generating systems*, *market network service facilities* and *loads* that include LIBR;
 - (iii) *considered projects*;
 - (iv) variations in *generation* and *load* profiles, including operating conditions at maximum and minimum *loads*, including under minimum *synchronous generation* conditions;
 - (v) AC and HVDC *interconnector* flows including (evaluation of) applicable *constraint* limitations;
 - (vi) *constraints*, limit equations and updates to these;
 - (vii) *credible contingency events* and other events set out in proposed *performance standards*;

⁵¹ See NER 4.6.6(b)(4).

- (viii) operation and impact of, and on, special protection schemes;
 - (ix) switching events or events that might cause *voltage* or operating condition variations to test for *adverse system strength impact* at different operating points;
 - (x) *protected events* and *constraints* that apply during those *protected events*; and
 - (xi) any other matters the Connecting NSP considers reasonable following agreement with AEMO.
- (d) A Full Assessment must exclude the impact on any *protection system* for a *transmission network* or *distribution network*⁵².

4.2.6. Methodology

Generally

- (a) A Full Assessment may be iterative or multi-part, and there are interdependencies with the acceptance of suitable models and *negotiated access standard* proposals, as well as the availability of models and model updates that could occur during planning and the *connection* assessment process.
- (b) Connecting NSPs must carry out *power system* modelling and simulation studies to demonstrate whether the application of all proposed SSRs⁵³ or any proposed SSCW can mitigate all identified *general system strength impacts*.

Studies to ascertain effectiveness of SSRs

- (c) For the Full Assessment, Connecting NSPs must include studies that cover *credible contingency events* and the matters in section 4.2.5 as a minimum.
- (d) When undertaking studies to ascertain the effectiveness of an Applicant's SSRs, Connecting NSPs may include likely *contingency events*.

Extent of power system model representation for Full Assessment

- (e) The required portion of the *power system* for PSCAD™/EMTDC™ modelling must be considered by the Connecting NSP on a case-by-case basis and could include any, or any combination, of the following:
 - (i) equivalent *network* representation(s) developed by the Connecting NSP with sufficient assumptions, confidence and justification for aggregating remote parts of the *power system*; or
 - (ii) provided it does not result in adverse interactions between *plant*, or *power system* instability, hybrid modelling where *plant* models in remote locations, or remote *regions*, can be represented in an RMS-type simulation tool, such as PSS®E.
 - (iii) complete PSCAD™/EMTDC™ type model of the NEM case provided by AEMO;
- (f) The chosen *power system* model must always include, as a minimum, all of the following:
 - (i) site-specific PSCAD™/EMTDC™ model of the 4.6.6 Connection;

⁵² See NER 4.6.6(b)(3).

⁵³ NER 5.3.4(g) requires an Applicant who proposes an SSRs under NER 5.3.4B to submit its proposal with the *application to connect*.

- (ii) PSCAD™/EMTDC™ model of *plant* in the electrical vicinity of the 4.6.6 Connection that could have an impact on the 4.6.6 Connection and on which the 4.6.6 Connection could have an impact;
 - (iii) PSCAD™/EMTDC™ model of SSRs⁵⁴ or proposed SSCW to mitigate the *general system strength impact* of the 4.6.6 Connection; and
 - (iv) PSCAD™/EMTDC™ model of all other *plant* dependant on, and impacted by, SSCW.
- (g) When determining the extent of the power system model necessary for PSCAD™/EMTDC™ modelling, the Connecting NSP must consider what *power system* phenomena or performance is being evaluated to confirm there is no *adverse system strength impact*, which may involve, without limitation:
- (i) sub-synchronous resonance;
 - (ii) control interactions; and
 - (iii) torsional interactions.

Alterations to Plant

- (h) If a Connecting NSP is required to carry out a Full Assessment in respect of an alteration to *plant* and the alteration is limited to one of the following, the Connecting NSP must only assess whether there is an *adverse system strength impact*:
- (i) alterations to firmware that do not impact ratings;
 - (ii) installation of reactive compensating equipment; or
 - (iii) like-for-like replacement in balance of *plant* items, such as cables and *transformers*.

4.2.7. Batch assessments

- (a) If a Full Assessment of a 4.6.6 Connection is impacted by one or more other 4.6.6 Connections that are not Committed, yet electrically close to each other, the Connecting NSP may undertake one Full Assessment for all impacted 4.6.6 Connections together, provided that the affected Applicants have agreed with the Connecting NSP to share the costs of any proposed system strength remediation.
- (b) Connecting NSPs will need to resolve, directly with the affected Applicants, any issues over the use and sharing of *confidential information* for the purposes of the Full Assessment.

4.2.8. Results to be provided to Applicants

Connecting NSPs must advise Applicants of the results of a Full Assessment and provide them the following information:

- (a) details of the studies undertaken by the Connecting NSP;

⁵⁴ NER 5.3.4(g) requires an Applicant who proposes an SSRS under NER 5.3.4B to submit its proposal with the *application to connect*.

- (b) details of the assumptions made by the Connecting NSP as to current and forecast *generation* patterns (including where proposed *generating systems* are Committed), *dispatch* during *contingency events*, *network* configurations, *augmentations*, and retirement of *network plant*;
- (c) how much of the *network* was modelled and how the rest of the *network* was addressed;
- (d) without disclosing any *confidential information*, the level of modelling detail assessed, particularly of the surrounding *network* and electrically close *generating systems* (including proposed *generating systems* considered), *market network service facilities*, and *loads* that include LIBR, either already *connected* or to be assessed in parallel;
- (e) whether FACTS devices have been included in the analysis;
- (f) an indication of the adequacy of the 4.6.6 Connection's capability under the prevailing system strength conditions; and
- (g) if the Connecting NSP identifies a *general system strength impact*, its reasons for a finding and suggestions on how the Applicant might be able to address the *general system strength impact*, including:
 - (i) *plant* performance improvements; and
 - (ii) the critical contingencies associated with the identified performance deficiency.

4.2.9. Timing of provision of results

There is no deadline prescribed in the NER for the provision of the Full Assessment results to the Applicant, however, the results must be provided to the Applicant prior to finalisation of the *negotiated access standards* for the 4.6.6 Connection.

4.2.10. Consultation with AEMO

- (a) The Connecting NSP must consult with AEMO on the results of the Full Assessment prior to delivering them to the Applicant, which must be undertaken concurrently with consultation during the assessment process for proposed *negotiated access standards* that are *AEMO advisory matters*.
- (b) The Connecting NSP must forward the results of the Full Assessment to AEMO at nem.connections@aemo.com.au.
- (c) Any concerns are to be discussed between the Connecting NSPs and AEMO in a timely manner to facilitate the Connecting NSPs' response to an Applicant in accordance with any program agreed with the Applicant.

5. System strength remediation

5.1. System strength remediation schemes

5.1.1. Timing of submission of SSRS

Unless they elect to pay the SSC or are willing to fund the Connecting NSP to undertake SSCW, Applicants are required to submit an SSRS with their *application to connect*⁵⁵ (where the 4.6.6 Connection comprises new *plant*) or submission⁵⁶ (where the 4.6.6 Connection comprises an alteration to other *connected plant*).

5.1.2. Acceptable SSRSs

Generally

- (a) SSRSs must be implemented behind the 4.6.6 Connection Point (that is, they must form part of the 4.6.6 Connection) and must address each element of the identified *general system strength impact*, namely, the *adverse system strength impact* and the reduction in AFL, as applicable.
- (b) This means that an SSRS must address the reduction in AFL at the 4.6.6 Connection Point and its *adverse system strength impact*, regardless of whether the *network* can operate stably despite the *adverse system strength impact* of the 4.6.6 Connection.
- (c) An SSRS can be constituted by more than one type of *plant*.

SSRS capable of addressing adverse system strength impact

- (d) The following is a non-exhaustive list of SSRSs that an Applicant could propose to mitigate or reduce its 4.6.6 Connection's *adverse system strength impact*:
 - (i) modifications to the 4.6.6 Connection's *control systems* (for example *control system* development, coordination and tuning);
 - (ii) new power lines or *transformers* within the 4.6.6 Connection, for example, the use of lower impedance *transformers* at either the collection grid or *network* interface;
 - (iii) installation of new *synchronous condensers* and other dynamic reactive *plant* as part of the 4.6.6 Connection;
 - (iv) use of grid-forming technologies; or
 - (v) installation of active or passive harmonic filters⁵⁷.

SSRS capable of addressing reduction in AFL

- (e) The following is a non-exhaustive list of SSRSs that could be used by an Applicant to address the reduction in AFL as a result of its 4.6.6 Connection:
 - (i) installation of *synchronous condensers*; or

⁵⁵ See NER 5.3.4B(g).

⁵⁶ See NER 5.3.9(b)(4) for alterations to *generating systems* and NER 5.3.12(b)(4) for alterations other types of *connected plant*.

⁵⁷ AEMO notes that these can only address a 4.6.6 Connection's *adverse system strength impact* (for example *harmonics*), so it can only be utilised in combination with something else that can reduce the AFL at the 4.6.6 Connection Point.

- (ii) installation of grid-forming technology.

Matters to be considered when assessing effectiveness of SSRS

An SSRS must be designed to address the *adverse system strength impact* and the reduction in AFL.

- (f) An SSRS should be designed to account for the difference between the Withstand SCR and the limitations of the *power system* at the 4.6.6 Connection Point (see 3.4.2), including, without limitation:
 - (i) thermal limits;
 - (ii) stability limits;
 - (iii) *voltage* (VAR compensation) regulation requirement;
 - (iv) permissible primary equipment ratings of Connecting NSP's *network*; and
 - (v) *load* or *generation* profile diversity etc.
- (g) Any proposed SSRS must be evaluated using time domain simulation and not the static short circuit methods (for example IEC60909, IEEE or ANSI short circuit calculation methods) since the voltage waveform stability is concerned with either pre- or post-contingent stability and thus not concerned with short circuit current evaluation during the fault.
- (h) SSRS involving IBR-based solutions: The time domain stability evaluation method allows consideration of more advanced IBR controls and utilisation of grid forming technologies as viable SSRS since their evaluation is not appropriate to be bound to static short circuit evaluation methods.
- (i) SSRS involving *synchronous condenser*-based solutions: Use and application of static short circuit methods for evaluation of *synchronous condensers* against a reduction in AFL must be complemented with time domain evaluations to determine the lowest Withstand SCR taking into account *power system* limitations.
- (j) The lowest SCR for the assessment of a proposed SSRS must consider *voltage* stability and maximum power transfer limits of the *power system* (or its Thevenin equivalent) at the 4.6.6 Connection.
- (k) The lowest Withstand SCR against which the Applicant must remediate the reduction in AFL caused by its 4.6.6 Connection, must not be less than 1.2 (i.e. stability coefficient, see section 3.4.2).

5.1.3. Timing of Assessment

An assessment of the adequacy of a proposed SSRS must be carried out after the Connecting NSP has completed a Full Assessment that clearly identifies the size of a 4.6.6 Connection's *general system strength impact*.

5.1.4. Type of assessment

Adverse system strength impact

- (a) Connecting NSPs must carry out *power system* modelling and simulation studies to demonstrate whether the proposed SSRS can remediate any identified *adverse system strength impact* without creating other adverse impacts.

AFL remediation

- (b) Connecting NSPs must carry out *power system* modelling and simulation studies to assess whether the proposed SSRS will address the identified reduction in the AFL caused by the 4.6.6 Connection, having regard to the matters in section 5.1.2(f) to (j).

5.1.5. Consultation with AEMO

- (a) A Connecting NSP is required to consult with AEMO as soon as practicable on the proposed SSRS⁵⁸, which is to include the Connecting NSP's analysis and conclusions on the proposal.
- (b) The Connecting NSP must forward the proposed SSRS and its analysis and conclusions to AEMO at nem.connections@aemo.com.au.
- (c) AEMO will use reasonable endeavours to respond to the Connecting NSP in respect of the proposed SSRS within 20 *business days* of its provision to AEMO⁵⁹ and the Connecting NSP must accept or reject the proposed SSRS within 10 *business days* following the receipt of AEMO's response⁶⁰.

5.1.6. Rejection of proposed SSRS

- (a) The Connecting NSP must reject an SSRS proposal if one or more of the following applies⁶¹:
 - (i) the SSRS is not reasonably likely to avoid or remediate the *general system strength impact* of the 4.6.6 Connection;
 - (ii) in the Connecting NSP's reasonable opinion, the SSRS would adversely affect the quality of *supply* for other *Network Users*; or
 - (iii) on AEMO's reasonable advice, the SSRS would adversely affect *power system security*.
- (b) The Connecting NSP must provide the Applicant with its reasons for rejecting a proposed SSRS. Where the rejection is based on AEMO's reasonable advice that the SSRS would adversely affect *power system security*, the Connecting NSP must provide a copy of AEMO's letter to this effect.
- (c) The avenues for further action and resolution following rejection of an SSRS are set out in NER 5.3.4B(n) to (p).
- (d) Where an SSRS will not remediate the *general system strength impact*, the 4.6.6 Connection may still proceed if the Applicant agrees to pay the cost of SSCW and AEMO agrees that the proposed SSCW will remediate the *general system strength impact*.

⁵⁸ See NER 5.3.4B(i).

⁵⁹ See NER 5.3.4B(j).

⁶⁰ See NER 5.3.4B(k).

⁶¹ See NER 5.3.4B(l).

5.1.7. Final approval

If an Applicant fails to ensure that an SSRS is constructed, installed or operated in accordance with the detailed designs approved by the Connecting NSP and AEMO under NER 5.3.4B:

- (a) where applicable, AEMO might refuse the Applicant's registration application, or allow it to register only at a lower capacity;
- (b) the Applicant might not be permitted to commence or continue commissioning its 4.6.6 Connection⁶²; or
- (c) *constraints* might be applied to limit the output or consumption of the *plant* associated with the 4.6.6 Connection.

5.2. System strength connection works

5.2.1. Need for system strength connection works

Where a Full Assessment indicates that an Applicant's 4.6.6 Connection will have a *general system strength impact*, the Connecting NSP must undertake SSCW at the Applicant's cost, unless one of the following applies⁶³:

- (a) the 4.6.6 Connection does not proceed;
- (b) to the extent that the *general system strength impact* is or will be avoided or remedied by an SSRS implemented by the Applicant in accordance with its *connection agreement*;
- (c) to the extent that the impact is below any Materiality Threshold; or
- (d) the Applicant has elected to pay the SSC.

5.2.2. Acceptable system strength connection works

SSCW capable of addressing general system strength impact

- (a) The following is a non-exhaustive list of SSCW that could be used by a Connecting NSP to increase the Synchronous Three Phase Fault Levels at the 4.6.6 Connection Point to address a *general system strength impact* created by the 4.6.6 Connection:
 - (i) new *transmission lines* or *transformers* external to the 4.6.6 Connection, potentially remote from the 4.6.6 Connection Point;
 - (ii) upgrades to *transmission lines* so they operate at a higher *voltage* level;
 - (iii) use of lower impedance *transformers* in the *network*;
 - (iv) reconfiguration of *networks*, for example, alternative switching arrangements involving 'normally open points' in the *network*, which may require upgrades to primary or secondary equipment; or

⁶² See NER 5.8.1(a), which generally requires the Applicant to ensure that any equipment is inspected and tested to demonstrate compliance with *Australian Standards*, the NER and the *connection agreement* prior to *connection* and NER 5.8.5(e), which permits a Connecting NSP to request AEMO to direct that commissioning not proceed if NER 5.8.1(a) not met. See also NER 5.3.10(b)(3) for equivalent provisions about alterations to *generating systems* and NER 5.3.13(b)(3) for alterations to other types of *connected plant*.

⁶³ See NER 5.3.4B(e) and (f).

- (v) installation of new *synchronous condensers* within the *network*.

Matters to be considered when assessing effectiveness of SSCW

- (b) Any increase of the Synchronous Three Phase Fault Level at the 4.6.6 Connection Point due to SSCW must be taken as an offset against the reduction in AFL.
- (c) The SSCW should be designed to account for the difference between the Withstand SCR and the limitations of the *power system* at the 4.6.6 Connection Point, including, without limitation:
 - (i) thermal limits;
 - (ii) stability limits;
 - (iii) voltage (VAR compensation) regulation requirement;
 - (iv) permissible primary equipment ratings of Connecting NSP's *network*; and
 - (v) *load or generation* profile diversity etc.
- (h) The assessment of SSCW is not concerned with lowering the Withstand SCR⁶⁴ and must be evaluated using a static short circuit method, taking into account the total increase in Synchronous Three Phase Fault Levels at the 4.6.6 Connection Point with the 4.6.6 Connection *disconnected*, followed by time domain network studies to confirm any *adverse system strength impact* with the 4.6.6 Connection *connected*.

5.2.3. Timing of assessment

This assessment must be carried out after the Connecting NSP has completed a Full Assessment that clearly identifies the size of a 4.6.6 Connection's *general system strength impact* and the extent to which the Applicant's SSRS does not remediate it.

5.2.4. Type of Assessment

Connecting NSPs must carry out *power system* modelling and simulation studies to demonstrate whether the proposed SSCW can remediate the identified *general system strength impact* without creating other adverse impacts.

6. System strength locational factor

6.1. Purpose of SSLF

The SSLF is a factor that applies to a 4.6.6 Connection Point, which must be calculated by Connecting NSPs after they receive a *connection* enquiry from an Applicant⁶⁵.

It is one of the variables used to calculate the SSC⁶⁶.

⁶⁴ Unlike the assessment of an SSRS, which is; see section 5.1.2.

⁶⁵ See NER 5.3.3(b)(3)(ii) and 5.3.4B(a)(2).

⁶⁶ See NER 6A.23.5(e). See also the flowcharts in section 2.5.3 as to the Applicant's choice of paying the SSC or proposing an SSRS.

6.2. Timing

A Connecting NSP must calculate an SSLF concurrently with a Preliminary Assessment⁶⁷.

6.3. Circumstances in which SSLF calculation is not required

A Connecting NSP is not required to calculate the SSLF for a 4.6.6 Connection where it determines, in accordance with these Guidelines, that it cannot reasonably be calculated or would be manifestly excessive⁶⁸. AEMO has not identified any circumstances in which an SSLF could not reasonably be calculated, other than the examples provided in the NER⁶⁹:

- (a) Where the SSLF tends to infinity.
- (b) Where it would result in an SSC that could not reasonably be expected to be paid in preference to SSCW or an SSRS.

6.4. Methodology for undertaking SSLF calculation

- (a) An SSLF must be representative of the impedance (electrical distance) between the 4.6.6 Connection Point and the applicable SSN and must use the AFL as its basis⁷⁰.
- (b) It is recommended that the applicable SSN is the nearest SSN that is located within the same *region* as the electrical location of the 4.6.6 Connection.
- (c) To undertake this calculation, Connecting NSPs are required to use the *network* data available in an OPDMS PSS@E case, or equivalent *network* model consistent with OPDMS, configured to 'system normal' operating conditions (if the 4.6.6 Connection is to be *connected to a distribution network*, the OPDMS case may include a more detailed representation of the relevant *distribution network* appended by the Connecting NSP). The calculation steps are as follows:
 - (i) *Network* information is set to consider system impedance only (i.e. having all current sources removed).
 - (ii) *Network* conditions must be set around the date the Connecting NSP estimates the Applicant and the Connecting NSP will have completed all requirements to be in a position to send a notification to AEMO under NER 5.3.7(g), 5.3.9(h) or 5.3.12(h), as applicable.
 - (iii) 'System normal' operating conditions mean that the *network* configuration must represent normal conditions (namely, not planned or short-term *outages*) for the majority of the time in any single year (for example, in a *distribution network*, where medium *voltage (MV)* interties are normally open, this is to be regarded as 'system normal').
 - (iv) Select the nearest SSN to the 4.6.6 Connection Point, which is measured in terms of electrical proximity. If the Connecting NSP is a TNSP, the relevant SSN must be the nearest that is situated within the Connecting NSP's *transmission network*.

⁶⁷ See NER 4.6.6(b)(1)(i).

⁶⁸ See NER 5.3.4B(a2) and (a3).

⁶⁹ See NER 4.6.6(b)(10).

⁷⁰ See 4.6.6(b)(9).

- (v) Insert a fault current source at SSN equivalent to the minimum (pre-contingent) fault level requirements *published* by AEMO for the relevant SSN⁷¹.
- (vi) Perform a short circuit assessment by applying a bolted three-phase-to-ground fault at the SSN and the 4.6.6 Connection Point. Using the short circuit impedance calculated from the short circuit assessments ($Z_{@4.6.6\text{Connection}}$, $Z_{@SSN}$), in per unit on a 100 MVA base, the magnitude of the difference between the two impedances ($|Z_{\text{distance from SSN}}| = |Z_{@4.6.6\text{Connection}} - Z_{@SSN}|$) will provide the locational factor related to the SSN.
- (vii) The SSLF is calculated using the following formula:

$$SSLF = 1.0 + |Z_{\text{distance from SSN}}|$$
- (viii) The resulting SSLF should be expressed to a minimum of 3 decimal places and not more than 4.
- (ix) For 4.6.6 Connection Points that are situated at the SSN, the SSLF will be unity.

6.5. Circumstances where a revision to SSLF is required

Once an Applicant has received the Connecting NSP's calculation of the SSLF, the Applicant may request the Connecting NSP to provide a revised SSLF for the 4.6.6 Connection⁷².

6.6. No averaging of SSLFs

SSLFs are specific to one SSN. Connecting NSPs must not average an SSLF across many SSNs, or over a five-year horizon.

7. Short circuit ratio

7.1. Definition of SCR

The NER define SCR as the Synchronous Three Phase Fault Level (in MVA) at the *plant connection point* divided by:

- (a) for a *generating system*, its rated *active power* (in MW);
- (b) for a *market network service facility*, its rated *power transfer capability* (in MW); and
- (c) for an IBL, its *maximum demand* at the *connection point* (in MW),

in each case, excluding any *fault current contribution* from the *plant* side of the *connection point* when calculating the *three phase fault level*.

For example, a 100 MW wind farm *connected* to a *network* with a Synchronous Three Phase Fault Level of 500 MVA at the wind farm's *connection point* will have an SCR of $500/100 = 5$.

⁷¹ See the latest System Strength Report, at <https://aemo.com.au/en/energy-systems/electricity/national-electricity-market-nem/nem-forecasting-and-planning/planning-for-operability>.

⁷² See NER 5.3.4B(a4).

7.2. SCR access standards

7.2.1. Minimum access standards

The NER require the following 4.6.6 Connections to exhibit *plant* capability sufficient to operate stably and remain *connected* at a minimum SCR of 3.0:

- (a) new asynchronous generating units and generating systems to the extent they relate to the asynchronous generating units⁷³;
- (b) new plant that includes an IBR⁷⁴;
- (c) a market network service facility to be connected to either a transmission network or a distribution network⁷⁵.

The references to SCR in these *access standards*, however, must be read as referring to the “withstand SCR” (**Withstand SCR**), which is representative of the lowest Synchronous Three Phase Fault Level provided by the *power system* at the 4.6.6 Connection Point necessary for the 4.6.6 Connection to operate stably.

7.3. SCR assessment

Assessment of conventional quasi-steady-state fault current requires the use of Synchronous Machine sub-transient impedance (no dynamic simulations are involved) which is different to the Withstand SCR assessment, see section 7.4.

7.3.1. Matters to be considered by the Connecting NSP

Generating unit commitment patterns are a key variable affecting system strength, along with the electrical impedance of the *network* between the 4.6.6 Connection and *generating centres*⁷⁶. If the Connecting NSP is not a TNSP, they must consult the relevant TNSP for advice on the minimum acceptable *commitment* patterns when undertaking minimum synchronous short circuit assessments.

7.3.2. Methodology for SCR assessment

- (a) Fault level calculations must consider an intact *network* as well as critical contingencies, with the minimum number of Synchronous Machines online consistent with the *system strength requirements*. Careful consideration must be given to which *network elements* provide the greatest support to system strength in the area of interest, and thus need to be considered as critical contingencies.
- (b) To undertake this calculation, Connecting NSPs are required to use the *network* data available in an OPDMS PSS@E case (where the 4.6.6 Connection is to a *distribution network*, the OPDMS case may include a more detailed representation of the relevant

⁷³ See NER S5.2.5.15. If the *asynchronous generating units* are incapable of meeting this requirement, there is provision for other arrangements, subject to agreement with AEMO, the Connecting NSP and relevant SSSP: see NER S5.2.5.15(e).

⁷⁴ See NER S5.3.11.

⁷⁵ See NER S5.3a.7.

⁷⁶ Low levels of commitment patterns are strongly correlated with low system strength.

distribution network appended by the Connecting NSP). This is to be configured, first, to 'system normal' operating conditions and calculated using the following steps:

- (i) *Network* information is set to consider Synchronous Machines only with all IBR devices removed. This would comprise a minimum number of *synchronous generating units* and *synchronous condensers* and other *plant* providing SSS.
 - (ii) *Network* conditions must be set around the date the Connecting NSP estimates the Applicant and the Connecting NSP will have completed all requirements to be in a position to send a notification to AEMO under NER 5.3.7(g), 5.3.9(h) or 5.3.12(h), as applicable.
 - (iii) 'System normal' operating conditions mean that the *network* configuration must represent normal conditions (namely, not planned or short-term *outages*) for the majority of the time in any single year (For example, in a *distribution network*, where MV interties are normally open, this is to be regarded as 'system normal').
 - (iv) For fault level calculations:
 - (A) terminal *voltages* are set to 1.0 pu (i.e. flat start conditions);
 - (B) fault level calculations use the Synchronous Machine sub-transient impedance (from a flat start);

consistent with steady state model setup for system strength in AEMO's System Strength and Inertia Reports⁷⁷.
 - (v) Perform a short circuit assessment by applying a bolted three-phase-to-ground fault at the 4.6.6 Connection Point.
 - (vi) The resulting short circuit current results should be expressed in MVA (typically referred to as SCMVA⁷⁸), inclusive of X/R ratio and R+jX impedance in per unit on 100 MVA base.
 - (vii) The resulting SCR = SCMVA / MW of the 4.6.6 Connection.
- (c) The process in paragraph (b) must be repeated with the *network* configured for each critical *contingency event*, or groups of *contingency events* where necessary, and results considered to determine the lowest applicable SCR estimate.
 - (d) Where Synchronous Machines local to the 4.6.6 Connection are vital to local system strength, full *outages* must be considered.
 - (e) Connecting NSPs must also take into account the SCR conditions for *protected events* consistent with the *general system strength impact* to identify any estimated drops in SCR below the Withstand SCR of the 4.6.6 Connection declared by the OEM. In this case, appropriate *dispatch constraint* limits may be applied subject to verification by dynamic simulation modelling to confirm there are no adverse impacts on *power system security* and, if there are, formulate the required limit advice.

⁷⁷ Published by AEMO at <https://aemo.com.au/energy-systems/electricity/national-electricity-market-nem/nem-forecasting-and-planning/system-security-planning>.

⁷⁸ SCMVA is the short circuit current expressed in MVA.

7.4. Withstand SCR assessment

The Withstand SCR of a 4.6.6 Connection is assessed, as a minimum, through dynamic simulation studies in a SMIB environment.

7.4.1. Methodology for demonstration of Withstand SCR

The purpose of the methodology is to ensure:

- (a) A reasonable effort has been made to accurately demonstrate that the *minimum access standard* or *negotiated access standard* requirements can be met at the relevant Withstand SCR.
- (b) Actual system SCR conditions are considered where possible, which may be at an SCR of ≤ 3.0 , demonstrated through acceptance of the *access standard* assessments and relevant information requirements⁷⁹. The lowest applicable SCR upon application of a *contingency event* in the *network* shall be stated as the lowest capability and the tests outlined in section 7.4.3 will be used to confirm the 4.6.6 Connection's Withstand SCR capability.

7.4.2. Matters to be considered by the Connecting NSP

- (a) An Applicant may propose to apply *control system* settings that are the same as those used when assessing other *access standards* (those not related to system strength) as a starting point.
- (b) The Connecting NSP may nominate, request, or assess, any other tests (including tests in the wide area *network*) reasonably required after taking into account:
 - (i) type of technology;
 - (ii) performance;
 - (iii) *network* point characteristics;
 - (iv) impact on system strength quantities or reductions in fault levels that might not be captured using the simplified SMIB set of tests specified in Appendix B; and
 - (v) impact on stability.

7.4.3. Tests to be carried out

To prevent studies being duplicated, the Applicant and Connecting NSP must discuss and agree how much modelling or tests the Applicant must carry out before providing the modelling and test results to the Connecting NSP.

For the purposes of a Preliminary Assessment

NER 4.6.6(b)(1A) requires a Preliminary Assessment to be carried out by the Connecting NSP using a simple isolated model, such as a single machine infinite bus (**SMIB**) model, but this applies only where site-specific PSCAD™/EMTDC™ of the 4.6.6 Connection are available.

⁷⁹ See Access Standard Assessment Guide and Generator Connection Application Checklist, at <https://aemo.com.au/energy-systems/electricity/national-electricity-market-nem/participate-in-the-market/network-connections/transmission-and-distribution-in-the-nem/stage-3-application>.

Where a Preliminary Assessment is being carried out using site-specific PSCAD™/EMTDC™ and PSS®E models of the 4.6.6 Connection, all tests listed in Appendix B must be completed as part of the Preliminary Assessment.

For the purpose of demonstrating compliance with proposed access standards

The Applicant may either confirm the Withstand SCR capability of its 4.6.6 Connection using the test results obtained during the Preliminary Assessment or carry out further tests to verify compliance with the proposed *access standards*.

Matters to be considered

Tests must be carried out using PSCAD™/EMTDC™ models.

Each test assesses the impact of system strength on fault ride-through (**FRT**) performance, impulse, and step responses, considering the following conditions:

- (a) balanced three-phase-to-ground faults;
- (b) fault impedance Z_f is a function of pre-fault Thevenin equivalent impedance Z_s ;
- (c) estimated X/R condition at the 4.6.6 Connection Point, or applicable range of X/R conditions;
- (d) for 4.6.6 Connections comprised of BESS, regardless of whether they are grid-forming or grid-following, all assessments must be conducted at full rated charging and discharging levels up to the maximum registered (or proposed) capacity, including at STATCOM operation (i.e. at zero *active power* output);
- (e) for HVDC systems, all tests need to take into account bidirectional power flows; and
- (f) for hybrid 4.6.6 Connections, all tests must be completed for each type of technology used by the 4.6.6 Connection, plus the combined 4.6.6 Connection as a whole.

7.4.4. Acceptance criteria

Tests will be considered acceptable if all of the following criteria or conditions are satisfied:

- (a) Unstable performance at an SCR of 3.0 must be rectified by the Applicant before providing the models to the Connecting NSP or AEMO, otherwise the 4.6.6 Connection will be deemed to be not capable of meeting the *minimum access standard*. Inverter blocking during FRT is not permitted, unless otherwise agreed with the Connecting NSP and AEMO.
- (b) HVRT and LVRT performance (for the commencement and the delivery of reactive support) must not be lower than the NER S5.2.5.5 *minimum access standard*.
- (c) Synthetic inertia modes, where used for *performance standards* (for example virtual synchronous generator mode used in grid-forming BESS) may be considered on a case-by-case basis, taking into account the size, location and the impact of the 4.6.6 Connection.
- (d) All model settings must be provided, and differences articulated between the settings used for other proposed *performance standards*, and the settings used to demonstrate compliance with NER S5.2.5.15, S5.3.11 or S5.3a.7, as applicable.
- (e) FRT performance must not oscillate, become unstable or uncontrolled during a disturbance or following the removal of applied disturbance.

- (f) Performance must not result in LVRT retriggers, or limit cycling between LVRT and high voltage ride-through (**HVRT**).
- (g) Performance must not be unstable prior to, during, and following, any contingencies.
- (h) The 4.6.6. Connection must not trip unless the operating conditions are outside of *power system* stability limits.
- (i) The 4.6.6. Connection must not continue indefinitely in FRT mode unless the operating conditions are outside of *power system* stability limits.
- (j) The 4.6.6. Connection level *voltage* controller must be enabled.
- (k) The 4.6.6. Connection level *frequency* controller must be enabled.
- (l) All starting conditions must be executed at a *voltage* level of 1.0 pu and not more than 2% deviation from nominal unless there are specific operating conditions that will apply at low SCR operation, including applicable *normal voltage*.
- (m) A minimum 15 s simulation time must be provided following clearance of the fault or completion of an event.
- (n) A report with simulated results must be provided for all studies.
- (o) PSCAD™/EMTDC™ plot resolution must not be worse than 1 ms.
- (p) The 4.6.6. Connection must demonstrate a stable simulation initialisation run > 30 s at an SCR of 3.0 or the proposed Withstand SCR. If the 4.6.6 Connection cannot demonstrate a stable initialisation run, namely, steady state operation, the 4.6.6 Connection will be deemed to be unable to demonstrate compliance with NER S5.2.5.15, S5.3.11 or S5.3a.7, as applicable.

7.5. Demonstration of compliance with SCR performance standards

Section 7.5 provides guidance on the information that must be provided when demonstrating compliance with the *access standards*⁸⁰ referred to in section 7.2.

7.5.1. Generators

Generators must demonstrate compliance with the *minimum access standard* in NER S5.2.5.15(b), or if the procedures in NER 5.3.4A have been followed, the *negotiated access standard*. The only guidance in the NER is that they are permitted to do so through the use of appropriate *control system* settings, *protection system* settings, or both. Moreover, the settings used may be different to the settings required for compliance with other *access standards* established under NER S5.2.5⁸¹.

The information to be provided by Generators is detailed in the Generator Connection Application Checklist.⁸²

⁸⁰ See NER 4.6.6(a)(4).

⁸¹ See NER S5.2.5.15(d).

⁸² At <https://aemo.com.au/en/energy-systems/electricity/national-electricity-market-nem/participate-in-the-market/network-connections/transmission-and-distribution-in-the-nem/stage-3-application>.

7.5.2. Network Users

Network Users must demonstrate compliance with the *minimum access standard* in NER S5.3.11(b), or if the procedures in NER 5.3.4A have been followed, the *negotiated access standard*. The only guidance in the NER is that they are permitted to do so through the use of appropriate *control system* settings, *protection system* settings, or both. Moreover, the settings used may be different to the settings required for compliance with other *access standards* established under NER S5.3⁸³.

The information to be provided by *Network Users* is consistent with that specified in the Generator Connection Application Checklist⁷⁹. Any queries as to whether any specific requirement should apply to a *Network User* should be referred to the Connecting NSP as well as AEMO at nem.connections@aemo.com.au for resolution.

7.5.3. MNSPs

MNSPs must demonstrate compliance with the *minimum access standard* in NER S5.3a.7(b), or if the procedures in NER 5.3.4A have been followed, the *negotiated access standard*. The only guidance in the NER is that they are permitted to do so through the use of appropriate *control system* settings, *protection system* settings, or both. Moreover, the settings used may be different to the settings required for compliance with other *access standards* established under NER S5.3a⁸⁴.

The information to be provided by MNSPs is consistent with that specified in the Generator Connection Application Checklist⁷⁹. Any queries as to whether any specific requirement should apply to an MNSP should be referred to the Connecting NSP as well as AEMO at nem.connections@aemo.com.au for resolution.

7.6. Changes to plant performance

Applicants whose *plant* is subject to one of the *access standards* referred to in section 7.2 must ensure that the ability of their *plant* to meet the relevant standard does not erode over time⁸⁵, even if the cause of an inability to meet the relevant standard is due to changes in *power system* conditions.

8. Stability Assessments

8.1. Requirement for Stability Assessment

If an Applicant elects to pay the SSC in accordance with NER 5.3.4B(b1), the Connecting NSP is required to undertake modelling in accordance with these Guidelines to verify the stability of the 4.6.6 Connection⁸⁶.

⁸³ See NER S5.3.11(c).

⁸⁴ See NER S5.3a.7(d).

⁸⁵ See NER 4.15 on the requirement to maintain compliance with relevant *performance standards*. See also <https://aemo.com.au/en/energy-systems/electricity/national-electricity-market-nem/system-operations/generator-performance-standards> where AEMO describes what to do in case of non-compliance with *performance standards*.

⁸⁶ See NER 5.3.4B(a2)(4).

8.2. Timing

A Connecting NSP must undertake a Stability Assessment of a 4.6.6 Connection upon receipt of the Applicant's *application to connect*, or submission under NER 5.3.9(b) or 5.3.12(b), that includes an election to pay the SSC⁸⁷.

8.3. Information to be provided by Applicants

The information to be provided by Applicants is the same as that required for a Full Assessment. See section 4.2.3.

8.4. Power system model

A Stability Assessment must be carried out using the same *power system* model as that which is reasonably appropriate for conducting a Full Assessment and applicable to the location in the *transmission network* or *distribution network*. Connecting NSPs will require (as a minimum) an appropriate, project-specific PSCAD™/EMTDC™ simulation model of the following:

- (a) The surrounding *network*, and *generating systems* and other *plant connected* to the *network* (which, for the avoidance of doubt, includes all relevant SSRS and SSCW) that could have an impact on the 4.6.6 Connection and on which the 4.6.6 Connection could have an impact.
- (b) All SSS applicable to the 4.6.6 Connection, namely, the SSS being funded through the SSC to be paid by the Applicant.
- (c) Where the Connecting NSP is not the relevant SSSP, the SSSP must provide the Connecting NSP with all relevant information and models to include the applicable SSS in the Connecting NSP's project-specific PSCAD™/EMTDC™ simulation model.

8.5. Matters to be considered by the Connecting NSP

The matters to be considered by Connecting NSPs are as detailed in section 4.2.5, plus the following:

- (a) Validity of *control systems*, settings and performance of SSS, including any changes that occur during planning, design and operation stages.
- (b) Location and size of SSS to achieve *voltage waveform* stability.
- (c) *Power system* stability for conditions caused by unplanned *outages* of SSS and the need for any special protection schemes.

8.6. Methodology

The purpose of a Stability Assessment is to confirm stability of the 4.6.6 Connection under NER 5.3.4B(a2)(4).

A Stability Assessment may be iterative or multi-part, and there are interdependencies with the acceptance of suitable models and *negotiated access standards*, as well as the availability of models and model updates that could occur during planning and the *connection* assessment process.

⁸⁷ See NER 5.3.4B(b1).

8.6.1. Studies to ascertain effectiveness of SSS

Connecting NSPs must carry out *power system* modelling and simulation studies to demonstrate the effectiveness of the SSS applicable to the 4.6.6 Connection⁸⁸ and the relevant SSSP's ability to meet the requirements of NER S5.1.14. These must include studies that cover *credible contingency events*.

8.6.2. Extent of power system model representation for Stability Assessment

- (a) The required portion of the *power system* for PSCAD™/EMTDC™ modelling must be considered by the Connecting NSP on a case-by-case basis and could include any, or any combination, of the following:
 - (i) equivalent *network* representation(s) developed by the Connecting NSP with sufficient assumptions, confidence and justification for aggregating remote parts of the *power system*; and
 - (ii) provided it does not result in adverse interactions between *plant*, or *power system* instability, hybrid modelling where *plant* models in remote locations, or remote *regions*, can be represented in an RMS-type simulation tool, such as PSS®E, are permitted.
 - (iii) complete PSCAD™/EMTDC™ type model of the NEM case provided by AEMO;
- (b) The chosen *power system* model must always include, as a minimum, all of the following:
 - (i) site-specific PSCAD™/EMTDC™ model of the 4.6.6 Connection and the SSS for the 4.6.6 Connection (namely, the SSS applicable to the 4.6.6 Connection⁸⁹); and
 - (ii) PSCAD™/EMTDC™ model of all *plant* and all Committed new *generating units*, *generating systems*, *market network service facilities* and *loads* that include LIBR in electrical vicinity of the 4.6.6 Connection.
- (c) When determining the extent of the *power system* model necessary for PSCAD™/EMTDC™ modelling, the Connecting NSP must consider what *power system* phenomena or performance is being evaluated to confirm there is no *adverse system strength impact*, which may involve, without limitation:
 - (i) sub-synchronous resonance;
 - (ii) control interactions; or
 - (iii) torsional interactions.

8.6.3. Batch Assessments

- (a) If a Stability Assessment of a 4.6.6 Connection is impacted by one or more other 4.6.6 Connections that are not Committed, yet electrically close to each other, the Connecting NSP may undertake one Stability Assessment for all impacted 4.6.6 Connections together, provided that all affected Applicants have elected to pay the SSC.

⁸⁸ As contemplated by section 8.4(b).

⁸⁹ As contemplated by section 8.4(b).

- (b) Connecting NSPs will need to resolve, directly with the affected Applicants, any issues over the use and sharing of *confidential information* for the purposes of the Stability Assessment.

8.7. Results to be provided to Applicants

Connecting NSPs must provide Applicants the results of a Stability Assessment and the information referred to in section 4.2.8.

8.8. Timing of provision of results

There is no deadline prescribed in the NER for the provision of the Stability Assessment results to the Applicant, however, the results must be provided to the Applicant prior to finalisation of the *negotiated access standards* for the 4.6.6 Connection.

8.9. Consultation with AEMO

- (a) Consistent with the requirements for consultation following the completion of a Full Assessment, Connecting NSPs must consult with AEMO on the results of a Stability Assessment prior to providing them to an Applicant.
- (b) To facilitate meaningful engagement with AEMO on the results of the Stability Assessment, Connecting NSPs may consult with AEMO on the results of the Stability Assessment concurrently with any consultation on proposed *performance standards* under NER 5.3.4A.
- (c) The Connecting NSP must forward the results of the Stability Assessment to AEMO at nem.connections@aemo.com.au.
- (d) The Connecting NSP must advise AEMO of the size and location of the SSS that were included in the Stability Assessment (the SSS applicable to the 4.6.6 Connection⁹⁰).
- (e) Any concerns are to be discussed between the Connecting NSPs and AEMO in a timely manner to facilitate the Connecting NSPs' response to an Applicant in accordance with any program agreed with the Applicant.

8.10. Consequence of plant instability

If the Connecting NSP is unable to verify stability of the 4.6.6 Connection at the conclusion of a Stability Assessment, the Connecting NSP must also identify the root cause of the instability. Following that, the Connecting NSP, in consultation with the Applicant, SSSP and AEMO is to consider whether the identified instability can be addressed by one or more of the following, after taking into account the benefits and costs of each available option:

- (a) improvement and optimisation of the SSS applicable to the 4.6.6 Connection;
- (b) optimisation of the 4.6.6 Connection, including:
 - (i) *control system* tuning; or
 - (ii) submission of an SSRS; or

⁹⁰ As contemplated by section 8.4(b).

- (c) resubmission by the Applicant of its *application to connect* or submission to alter *plant* (as applicable) by altering one or more of the following 4.6.6 Connection parameters:
 - (i) *plant capacity*;
 - (ii) *location*; or
 - (iii) *technology*.

9. Identifying committed projects

9.1. Provision of database

AEMO provides a secure database to NSPs to enable them to notify each other of the identity of each Committed *generation, market network service facility* or IBR Facility project (**project**) within their *network*.

The database will be accessible through the secure AEMO website available only to NSPs.

9.2. Updates to database

Each Connecting NSP is responsible for the content of the database in respect of projects within its own *network*.

The Connecting NSP must update the database by uploading information about new projects or updates to existing projects within two *business days* of the project becoming Committed or the relevant update, including any decision to de-Commit.

Appendix A. Example of Δ AFL Calculation

Consider a simple test system in Figure 4.

Figure 4 Test system for example AFL calculation

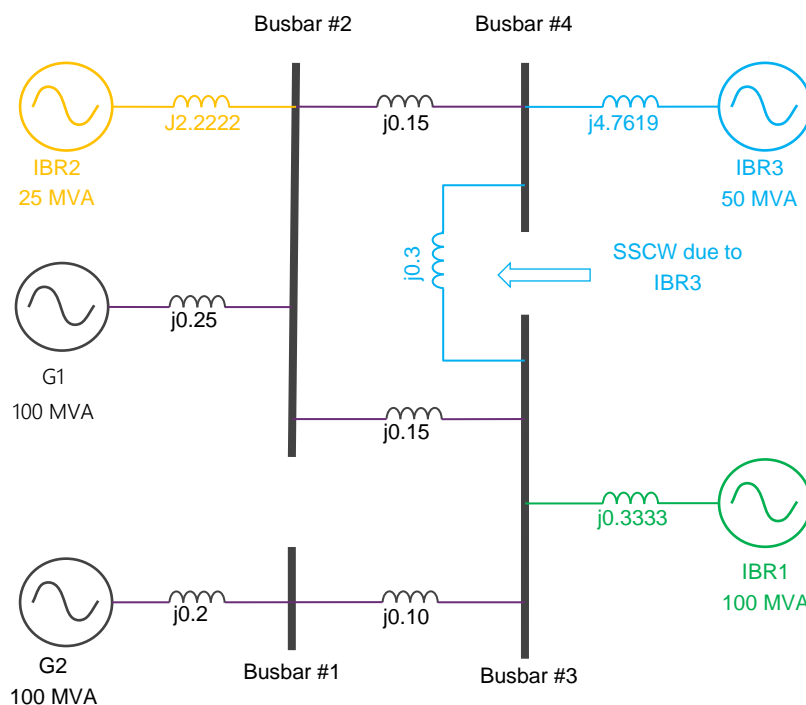

A.1 Calculation of Δ AFL for 4.6.6 Connections

Δ AFL for IBR1

IBR1 is a 100 MW *asynchronous generating system connected at busbar #3*, which has been in operation prior to 2023. There is no SSRS or SSCW associated with it. The known minimum SCR at its *connection point* for stable operation of IBR1 is 4.2. Therefore, the Δ AFL is calculated at its connection point as:

$$\Delta AFL_{IBR1} = (-SCR_{withstand} + \alpha) \times P_{rated} = (-4.2 + 1.2) \times 100 = -300 \text{ MVA}$$

For the purpose of the AFL calculation, the proxy Thevenin impedance for IBR1 is calculated, in system base of 100 MVA, as:

$$Z_{AFL_{IBR1}} = \left| \frac{1}{\Delta AFL_{IBR1}} \right|_{S_{base}=100MVA} = \frac{1}{300MVA/100MVA} = 0.3333 \text{ p.u.}$$

Δ AFL for IBR2

IBR2 is a 25 MW *asynchronous generating system to be connected at busbar #2 after 2023*. Following a Preliminary Assessment, the Connecting NSP has determined that IBR2 will have a *general system strength impact*, in that it reduces the AFL at the proposed *connection point*. The Applicant has chosen to pay the SSC, which means there will be no SSRS or SSCW if the Stability Assessment indicates no *adverse system strength impact*. The inverter technology

deployed for IBR2 is of the grid-following type (wind) with a Withstand SCR of 3.0. Therefore, the ΔAFL for IBR2 is calculated as:

$$\Delta AFL_{IBR2} = (-SCR_{withstand} + \alpha) \times P_{rated} = (-3.0 + 1.2) \times 25 = -45 \text{ MVA}$$

For the purpose of the AFL calculation, the proxy Thevenin impedance for IBR2 is calculated, in system base of 100 MVA, as:

$$Z_{AFL_{IBR2}} = \left| \frac{1}{\Delta AFL_{IBR2}} \right|_{S_{base}=100MVA} = \frac{1}{45MVA/100MVA} = 2.2222 \text{ p.u.}$$

ΔAFL for IBR3

IBR3 is a 50 MW *asynchronous generating system* to be *connected* at busbar #4 after 2023. Following a Preliminary Assessment, the Connecting NSP has determined that IBR3 will have a *general system strength impact*, in that it reduces the AFL at the proposed *connection point*. The composition of IBR3 consists of the following:

- 45 MW total capacity wind turbine of grid-following type inverter
- 20 MW total capacity BESS of grid-forming inverter

The Withstand SCR, assessed in accordance with section 7.3, for IBR3 is 1.62.

The Applicant has chosen to remediate the *general system strength impact* by paying for SSCW carried out by the Connecting NSP (construction of a new *transmission line* between busbar #4 and busbar #3). Since the SSCW increases the synchronous 3 phase fault level at the connection point of IBR3 by more than the amount of AFL reduction due to IBR3 connection, and, if the Stability Assessment indicates no *adverse system strength impact*, the effective ΔAFL is zero.

For the purpose of the calculation of AFL at system busbars in section A.2, the proxy Thevenin impedance for IBR3 is calculated, in system base of 100 MVA, as:

$$Z_{AFL_{IBR3}} = \left| \frac{1}{(-1.62 + 1.2) \times 50/100} \right|_{S_{base}=100MVA} = 4.7619 \text{ p.u.}$$

A.2 Calculation of AFL at system busbars

AFL calculations for **busbar #1** are shown here as a sample. Using the methodology outlined in section 3.4.3:

Step 2:	Synchronous Three Phase Fault Level at busbar #1	
	G1 contribution = 100 MVA / (0.25 + 0.15 0.45 + 0.1)	= 216 MVA
	G2 contribution = 100 MVA / 0.2	= 500 MVA
	TOTAL Synchronous Three Phase Fault Level @ busbar # 1	= 716 MVA
Step 3:	Proxy fault level at busbar #1 (including all IBRs) ⁹¹	
	G1 contribution	= 164 MVA
	G2 contribution	= 500 MVA

⁹¹ Obtained by running a short-circuit analysis in PSS®E using short circuit fault calculation with three phase fault and a voltage factor of unity.

	IBR1 contribution	= 186 MVA
	IBR2 contribution	= 18 MVA
	IBR3 contribution	= 10 MVA
	TOTAL proxy fault level @ busbar #1	= <u>878 MVA</u>
Step 4:	Calculate difference between Synchronous Three Phase Fault Level and proxy fault level	
	878 MVA - 716 MVA	= <u>162 MVA</u>
Step 5:	AFL at busbar #1	
	716 MVA - 162 MVA	= 554 MVA

The process can be repeated for all busbars. The results are shown in Table 1.

Table 1 AFL calculation for the example network

Busbar	Synchronous FL	Proxy FL	Difference	AFL
1	716	878	162	554
2	642	830	188	454
3	609	942	333	276
4	421	525	104	317

Appendix B. Withstand SCR tests

Table 2 Minimum set of tests for demonstration of stability [at SCR of 3.0 or lower]

Test	Fault duration	Fault type	Fault impedance Z_f [pu]	Applied Fault Voltage [pu]	Withstand SCR [pre-fault] to [post-fault]	X/R	Active Power [pu]	Reactive Power [pu]
1	0.43	3PHG	$Z_f=0$	0	For tests 1 to 10: Single SCR value is applied as per NER S5.2.5.15 (SCR of 3.0 (<i>minimum access standard</i>) or <i>negotiated access standard</i>).	Single applicable value at POC, expected or estimated range. (in absence of estimated range, use X/R of 3 and 10)	1	0
2	0.43	3PHG	$Z_f=0.11 \times Z_s$	~0.1			1	0
3	0.43	3PHG	$Z_f=0.25 \times Z_s$	~0.2			1	0
4	0.43	3PHG	$Z_f=0.42 \times Z_s$	~0.3			1	0
5	0.43	3PHG	$Z_f=0.66 \times Z_s$	~0.4			1	0
6	0.43	3PHG	$Z_f=Z_s$	~0.5			1	0
7	0.43	3PHG	$Z_f=1.5 \times Z_s$	~0.6			1	0
8	0.43	3PHG	$Z_f=2.3 \times Z_s$	~0.7			1	0
9	0.43	3PHG	$Z_f=4 \times Z_s$	~0.8			1	0
10	0.43	3PHG	$Z_f=9 \times Z_s$	~0.9			1	0
11	0.43	3PHG	$Z_f=0$	0	For Tests 11 to 20: change from pre-fault Withstand SCR of 10 to the post-fault Withstand SCR (SCR of 3.0 (<i>minimum access standard</i>) or <i>negotiated access standard</i>).	1	0	
12	0.43	3PHG	$Z_f=0.11 \times Z_s$	~0.1		1	0	
13	0.43	3PHG	$Z_f=0.25 \times Z_s$	~0.2		1	0	
14	0.43	3PHG	$Z_f=0.42 \times Z_s$	~0.3		1	0	
15	0.43	3PHG	$Z_f=0.66 \times Z_s$	~0.4		1	0	
16	0.43	3PHG	$Z_f=Z_s$	~0.5		1	0	
17	0.43	3PHG	$Z_f=1.5 \times Z_s$	~0.6		1	0	
18	0.43	3PHG	$Z_f=2.3 \times Z_s$	~0.7		1	0	
19	0.43	3PHG	$Z_f=4 \times Z_s$	~0.8		1	0	
20	0.43	3PHG	$Z_f=9 \times Z_s$	~0.9		1	0	

NOTE: 3PHG means three-phase-to-ground.
 POC means 4.6.6 Connection Point.
 The Applied Fault Voltage pu is an indicative residual voltage as a result of the application of fault impedance Z_f .

The tests listed in Table 3 and Table 4 only apply to PSCAD™/EMTDC™ models.

Table 3 Minimum set of tests for impulse and voltage step tests [at SCR of 3.0 or lower]

Test	Event	Withstand SCR	X/R	Active Power [pu]	Reactive Power [pu]
1	Grid voltage is stepped from 1 pu at time = 10 s to 0.95 pu, and stepped back to 1.0 pu at time = 15 s	As per NER S5.2.5.15	Single applicable value at POC, expected or estimated range. (in absence of estimated range, use X/R of 3 and 10)	1	0
2	Grid voltage impulse from 1.0 pu to 0.95 pu is applied at time = 10 s for a duration of 40 ms			1	0
3	Grid voltage impulse from 1.0 pu to 0.90 pu is applied at time = 10 s for a duration of 40 ms			1	0

NOTE: POC means 4.6.6 Connection Point

Table 4 Minimum set of tests for impedance change to SCR of 3.0 [or lower]

Test	Event	Withstand SCR [pre-event] to [post-event]	X/R	Active Power [pu]	Reactive Power [pu]
1	@time = 10 s grid impedance is changed	: Change from pre-fault Withstand SCR of 10 to the post-fault Withstand SCR (SCR of 3.0 (<i>minimum access standard</i>) or <i>negotiated access standard</i>)	Single applicable value at POC, expected or estimated range. (in absence of estimated range, use X/R of 3 and 10)	1	0

NOTE: POC means 4.6.6 Connection Point

Version release history

Version	Effective date	Summary of changes
2.0	15 March 2023	Amended following the National Electricity Amendment (Efficient management of system strength on the power system) Rule 2021
1.0	1 July 2018	First version following Final Determination of the National Electricity Amendment (Managing power system fault levels) Rule 2017