



Procedure for the Exercise of the Reliability and Emergency Reserve Trader

Prepared by: AEMO Systems Performance and Commercial

Document ref: SO_OP_3717

Version: 6.2

Effective date: 3 June 2024

Status: FINAL

Approved for distribution and use by:

Approved by: Michael Gatt

Title: Executive General Manager Operations

Date: 31/05/2024

aemo.com.au

New South Wales | Queensland | South Australia | Victoria | Australian Capital Territory | Tasmania | Western Australia

Australian Energy Market Operator Ltd ABN 94 072 010 327

Contents

Current version release details	3
1. Introduction	4
1.1. Purpose and scope	4
1.2. Definitions and interpretation	4
1.3. Related documents	5
2. RERT Panel recruitment	5
3. Publication of notices	5
3.1. Notice of intention to commence reserve contract negotiations	5
3.2. Publishing of reserve contract details	5
4. Ensuring reserves are not otherwise offered to the market	5
4.1. Unscheduled reserves	5
4.2. Scheduled Reserves (including in relation to wholesale demand response units and bidirectional units)	6
5. Determining the term and quantity of reserves to be contracted	6
5.1. Trigger for determination	6
5.2. Term and target quantity	7
5.3. AEMO to consider effectiveness of reserve	9
6. Basis for determining the estimated average VCRS	9
7. Methodology to dispatch and activate reserve contracts	9
7.1. Communication	9
7.2. Selecting reserve blocks	9
8. Dispatch of scheduled reserve	10
8.1. Key terminology	10
9. Activation of unscheduled reserve	11
9.1. Key terminology	11
Version release history	13

Figures

Figure 1	Timeline for fast response reserve (Forecast LOR2 from T2 to T5)	10
Figure 2	Timeline for slow response reserve (Forecast LOR2 from T3 to T6).....	10
Figure 3	Timeline for fast response unscheduled reserve (Forecast LOR2 from T2 to T5).....	11
Figure 4	Timeline for slow response unscheduled reserve (Forecast LOR2 from T3 to T4).....	12

Current version release details

Version	Effective date	Summary of changes
6.2	3 June 2024	Minor updates to reflect the National Electricity Amendment (Integrating energy storage systems into the NEM) Rule 2021 and Rule 2023 No. 2, with reference to bidirectional units. Effective 3 June 2024.

Note: There is a full version history at the end of this document.

1. Introduction

1.1. Purpose and scope

These are the Procedures for the Exercise of the Reliability and Emergency Reserve Trader (**RERT**) made under Clause 3.20.7(e) (**Procedures**).

These Procedures have effect only for the purposes set out in the National Electricity Rules (**NER**). The NER and the National Electricity Law prevail over these Procedures to the extent of any inconsistency.

1.2. Definitions and interpretation

1.2.1. Glossary

Terms defined in the National Electricity Law, the NER, and the RERT Guidelines have the same meanings in these Procedures unless otherwise specified in this clause.

Terms defined in the NER are intended to be identified in these Procedures by italicising them, but failure to italicise a defined term does not affect its meaning.

In addition, the words, phrases and abbreviations in the table below have the meanings set out opposite them when used in these Procedures.

Term	Definition
EAAP	Energy Adequacy Assessment Projection
ESOO	Electricity Statement of Opportunities
Long Notice Reserve	<i>Reserve</i> contracted in Long Notice Situations
Long Notice Situations	Situations where <i>AEMO</i> has between 12 months and 10 weeks' notice of a projected shortfall in <i>reserves</i> .
Medium Notice Reserve	<i>Reserve</i> contracted from RERT Panel Members in Medium Notice Situations.
Medium Notice Situations	Situations where <i>AEMO</i> has between 7 days' and 10 weeks' notice of a projected shortfall in <i>reserves</i> .
NEL	<i>National Electricity Law</i>
NER	<i>National Electricity Rules</i>
RERT Panel	A panel of entities recruited by <i>AEMO</i> that might be called upon to tender for and enter into a <i>reserve contract</i> in Medium Notice Situations and Short Notice Situations.
PASA	<i>Projected Assessment of System Adequacy</i>
Short Notice Reserve	<i>Reserve</i> contracted from RERT Panel Members in Short Notice Situations.
Short Notice Situations	Situations where <i>AEMO</i> has less than 7 days' notice of a projected shortfall in <i>reserves</i> .

1.2.2. Interpretation

These Procedures are subject to the principles of interpretation set out in Schedule 2 of the National Electricity Law.

1.3. Related documents

Reference	Title	Location
N/A	RERT Guidelines	AEMC website https://aemo.com.au/energy-systems/electricity/emergency-management/reliability-and-emergency-reserve-trader-rert
SO_OP_3707	Intervention, Direction and Clause 4.8.9 Instructions	AEMO website https://aemo.com.au/en/energy-systems/electricity/national-electricity-market-nem/system-operations/power-system-operation/power-system-operating-procedures
N/A	Intervention Pricing Methodology	AEMO website https://aemo.com.au/energy-systems/electricity/national-electricity-market-nem/system-operations/dispatch-information/policy-and-process-documentation

2. RERT Panel recruitment

Recruitment for the RERT Panel will, subject to the RERT Guidelines, be at AEMO’s discretion. The AEMO website will contain the necessary details for participants seeking to become members of the RERT Panel.

3. Publication of notices

3.1. Notice of intention to commence reserve contract negotiations

Notices *published* in accordance with clause 3.20.3(c) of the NER will be *published* in a market notice.

3.2. Publishing of reserve contract details

Notices published in accordance with section 8 of the *RERT Guidelines*, including:

- the name of each *reserve contract* counterparty; and
- the volume and timing of the *reserve* contracted under each *reserve contract*

will be *published* on AEMO’s website.

4. Ensuring reserves are not otherwise offered to the market

4.1. Unscheduled reserves

AEMO’s request for expressions of interest and invitations to tender will require information to be provided, or undertakings given, by respondents to AEMO, in relation to *unscheduled reserves*, to satisfy itself that a person complies with clause 3.20.3(i) of the NER, including:

- providing written confirmation that any offered unscheduled reserve is not subject to another contract or arrangement under which it is required to be offered in the market for the trading intervals to which the contract with AEMO relates; and
- provide the consent of the customer or generator (as applicable) at the applicable connection point to allow AEMO, where practicable, to contact the retailer (if applicable) and the Network Service Provider for that point to confirm the unscheduled reserve is not subject to another contract or arrangement.

All *unscheduled reserve contracts* will require the provider of the unscheduled reserves to ensure that the unscheduled reserves the subject of the *unscheduled reserve contract* are not otherwise engaged for any of the *trading intervals* to which the contract with AEMO relates.

4.2. Scheduled Reserves (including in relation to wholesale demand response units and bidirectional units)

AEMO's request for expressions of interest and invitations to tender will require information to be provided, or undertakings given, by respondents to AEMO, in relation to scheduled reserves, to satisfy itself that a person complies with clause 3.20.3(h) of the NER, including providing written confirmation that:

- dispatch bids will not have been submitted, and the capacity will not have been otherwise available for dispatch for the 12-month period immediately preceding the date of execution of the proposed scheduled reserve contract, and
- dispatch bids will not be submitted, and the capacity will not be otherwise available for dispatch for the duration of the proposed scheduled reserve contract,

except where dispatched under a reserve contract.

All scheduled reserve contracts will require the provider to ensure that dispatch bids are not submitted and the capacity is not otherwise available for dispatch for the duration of the scheduled reserve contract, except where that capacity is dispatched under the scheduled reserve contract.

5. Determining the term and quantity of reserves to be contracted

5.1. Trigger for determination

The process for determining to enter into a reserve contract (other than a reserve contract for interim reliability reserves) is triggered when a declaration is made under clause 4.8.4 of the NER. This will occur when either:

- in the case of long-notice and medium-notice situations, a region's forecast unexpected unserved energy (USE) exceeds the reliability standard as assessed in accordance with the reliability standard implementation guidelines (low reserve condition); or

- in the case of short-notice situations, the probability of load shedding (other than the reduction or disconnection of interruptible load) is, or is forecast to be, more than remote (lack of reserve condition).

Reserve contracts for interim reliability reserves

The process for determining to enter into a reserve contract for interim reliability reserves (interim reliability contract) is described in rule 11.128.4(f) of the NER.

5.2. Term and target quantity

Long-notice and medium-notice RERT

When a single region exceeds the reliability standard, the term and target quantity of reserve is determined by calculating the reserve required to reduce expected USE to the reliability standard. Subject to accounting for any reliability discount or limitations on availability, the following describes the calculation of the target quantity of reserve :

- Extract interval level USE from AEMO modelling simulations.
- For an additional 'x' MW of reserves, recalculate the interval level USE as:
- Adjusted USE = $\text{Max}(0, \text{Original USE} - x)$
- Determine the target level of 'x' reserves such that adjusted USE is equal to the reliability standard.

Where there are multiple regions with expected USE exceeding the reliability standard, the following approach is applied:

- Extract interval level USE for all regions from AEMO reserve modelling simulations (for example those used for MT PASA and ESOO), as well as the interconnector flow and limits in all periods where USE occurs in any region.
- Assume that the reliability standard is exceeded in N regions and consider the effect of an additional x_1, x_2, \dots, x_N MW of reserves (where x_1 refers to the additional reserves added in region 1). These reserves are available across all intervals where there is USE in any region. For each of the N regions, apply the following calculation to each interval:

$$\text{Adjusted USE} = \text{Max}(0, \text{Original USE} - x_i)$$

This calculation essentially assumes that additional reserves are used in the local region in the first instance. The following calculation then determines for each interval whether there are excess reserves that could then be used to reduce USE in neighbouring regions:

$$\text{Excess Reserves} = \text{Max}(0, x_i - \text{Original USE})$$

In each period, these excess reserves would only be used where a region has spare export capacity to a neighbouring region. Therefore, for reserves to be shared in a given interval, the following conditions must be met:

- A region has excess reserves after meeting any USE within the region.
- There is spare export capacity to a neighbouring region.

- The neighbouring region has USE remaining after using any additional reserves assumed to be available in that region.
- Apply excess reserves across regions for each interval within the financial year where any region has USE in accordance with the following:
 - If the Victorian region has excess reserves (and therefore has no remaining USE) and has spare export capacity to South Australia, and South Australia has remaining USE, reserves are shared up to the level of excess reserves in Victoria, capped at the spare export capacity from Victoria to South Australia. That is,
 - Reserves Shared = $\text{Min}(\text{excess reserves in Victoria, spare export capacity from Victoria to South Australia})$
 - In the reverse situation (where South Australia has excess reserves and Victoria has USE remaining), reserves are shared up to the level of excess reserves in South Australia, capped at the spare export capacity from South Australia to Victoria.
 - Note that in a given interval, the ability to share reserves can only occur in one direction between a pair of regions, as the sharing of reserves requires that all of the USE within one region is met by the additional reserves. However given this is applied to all intervals independently, there may be some intervals where South Australia shares reserves with Victoria and other intervals where Victoria shares with South Australia, and others where there is no ability to share at all.
 - The same calculation is then repeated between Tasmania and Victoria, Victoria and New South Wales, and New South Wales and Queensland.
- Based on these calculations, a set of additional reserves (x_1, x_2, \dots, x_N) is determined that when applied across all periods, reduces the expected USE such that all regions meet the reliability standard. This calculation may have many solutions. For example if South Australia and Victoria both exceed the reliability standard, the following combinations could both achieve the objective of reducing USE to the reliability standard in both regions:
 - 200 MW in region 1, 0 MW in region 2
 - 100 MW in region 1, 80 MW in region 2
- Where there are many combinations, AEMO will give consideration to the relative costs and features of proposed reserve when determining the most effective portfolio of reserves to be contracted. In the above example, the latter option requires a lower quantity of additional reserves, but if the cost or features of the reserves in region 2 were inferior to those in region 1, the first option may be a more effective means of addressing the reliability issues.

Short-notice RERT

The term and target quantity of reserve to be contracted will be the minimum reserve required to address a forecast or actual LOR2 and/or LOR3 condition as described in the Reserve Level Declaration Guidelines. Where there is spare export capacity between regions, AEMO will consider reserves levels across multiple regions together in the same manner as long-notice and medium-notice situations.

Interim reliability reserve contracts

The term and target quantity reserve for an interim reliability reserve contract that is not a multi-year contract will be determined in the same manner as long-notice and medium-notice reserve contracts as described in this Procedure, except that the interim reliability measure applies instead of the reliability standard. The term and target quantity of a multi-year reserve contract will be determined in accordance with the RERT Principles and rule 11.128.4 of the NER.

5.3. AEMO to consider effectiveness of reserve

When considering bids to provide reserve, AEMO may apply a discount factor to the quantity of nominal reserve offered under a tender to determine an effective quantity of reserve likely to be available upon activation. AEMO's estimate of the effective reserve will consider factors such as the historical performance of the reserve and likely availability profile across time.

6. Basis for determining the estimated average VCRS

For the purposes of clause 3.20.7(e)(3) and 3.20.2(b)(3) of the NER, AEMO will use the energy-weighted average aggregate VCR values (or equivalent where possible) published for each region.

7. Methodology to dispatch and activate reserve contracts

7.1. Communication

AEMO will issue instructions to *reserve* providers in accordance with each applicable *reserve contract*.

7.2. Selecting reserve blocks

There may be some *reserve* that cannot be used in a particular instance, for example, because binding network constraints prevent access to the *reserve* or there may be insufficient time to use the *reserve* because the reserve condition was forecast at short notice compared to the reserve's lead time for *dispatch* or *activation*. Such *reserve* will not be considered for *dispatch* or *activation*.

Selection of the particular *reserve* to be *dispatched* or *activated* will be based on a number of factors including, but not limited to the following:

- ability to meet the requirement
- cost
- size of *reserve* blocks
- length of *dispatch* or *activation* times

- *dispatch* or *activation* constraints (for example, maximum number of days or consecutive days per week of *dispatch* or *activation*, maximum and/or minimum periods of *dispatch* or *activation*)
- shutdown periods when the *reserve* blocks are not available.

8. Dispatch of scheduled reserve

Scheduled resource is registered in the AEMO Market Management System (MMS) with a unique Dispatch Unit Identification (DUID). Dispatch of *scheduled reserve* is through normal market processes using constraint equations which include the relevant DUIDs.

8.1. Key terminology

Figure 1 Timeline for fast response reserve (Forecast LOR2 from T2 to T5)

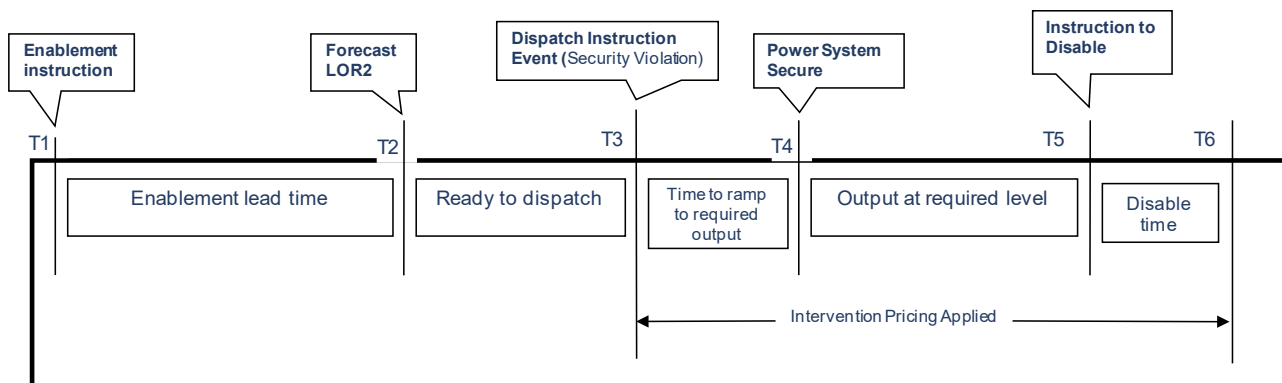
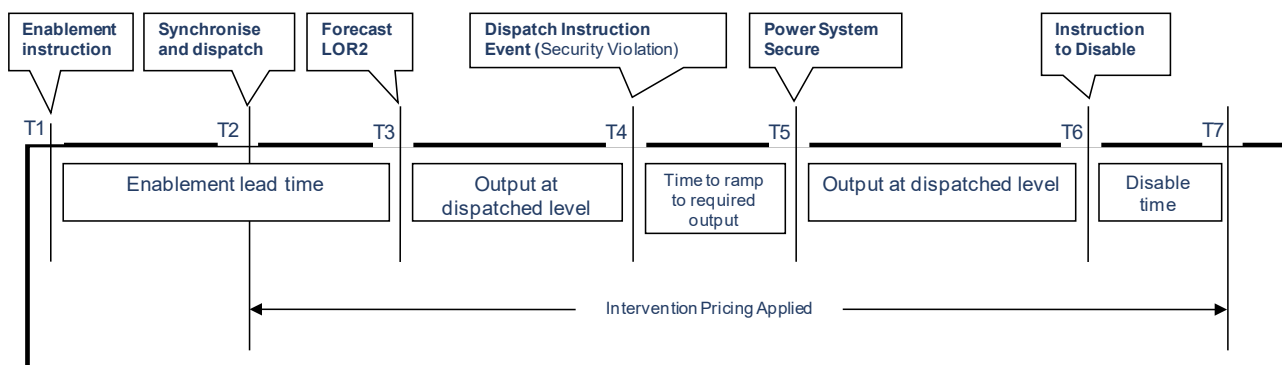

Figure 2 Timeline for slow response reserve (Forecast LOR2 from T3 to T6)



Enablement means preparing the *reserve equipment* to be *dispatched*. For example, Figure 1 demonstrates a fast response generator that does not need to be synchronised at the forecast LOR2 time (T2) to provide the reserve capacity. Note: a slow response generator may require *synchronising* and *loading* to its *minimum operating level* or some nominated level at the start of the LOR2 period (as shown in Figure 2), so that it can provide the reserve capacity within the timeframe required.

Enablement Lead Time means the maximum period required from the time the *Reserve Provider* receives an *enablement instruction* until the *reserve equipment* is:

- (a) synchronised and its loading level becomes equal to the minimum operating level for slow start plant;
- (b) ready for synchronisation for fast start plant; or
- (c) ready to be dispatched above its market capacity,

Dispatch Instruction means an *instruction* from AEMO to the Reserve Provider to *dispatch* reserve or to *disable* the reserve equipment (as the case may be).

Disablement means the cessation of the provision of reserve required by a *dispatch instruction* and resuming the taking of electricity supply.

Disablement Lead Time means the period required to *disable* the reserve equipment

9. Activation of unscheduled reserve

Unscheduled resource is not registered in the AEMO MMS with a unique DUID. Activation of *unscheduled reserve* appears in the *market* as a decrease in scheduled demand. In the MMS, AEMO has implemented generic *RERT* DUIDs for the purpose of activating unscheduled reserve.

Activation in the MMS is a two-part process involving:

1. Constraint equations which act on the generic *RERT* DUIDs
2. Submitting a reserve schedule using the Load Forecasting package.

The reserve schedule ensures the PASA reserve calculation is accurate by modifying the load forecast to take into account the reduction in scheduled demand due to the activation of *unscheduled reserve*.

9.1. Key terminology

Figure 3 Timeline for fast response unscheduled reserve (Forecast LOR2 from T2 to T5)

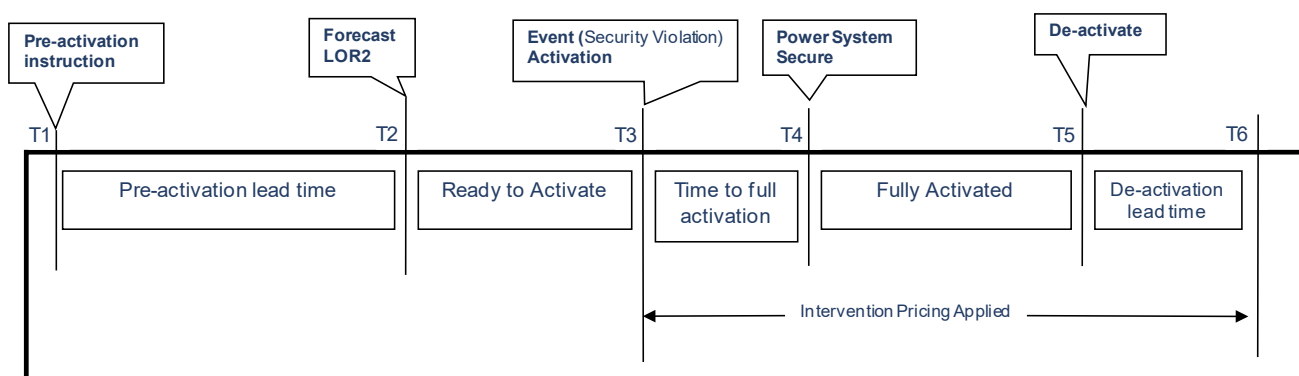
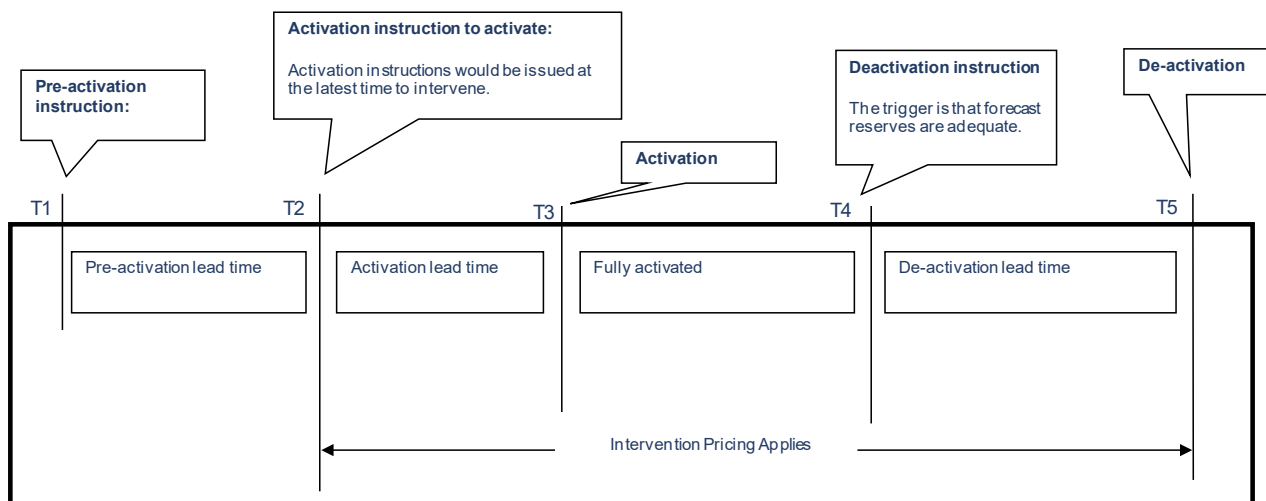

Figure 4 Timeline for slow response unscheduled reserve (Forecast LOR2 from T3 to T4)



Pre-activation means preparing the *reserve equipment* for activation.

Pre-activation lead time means the maximum period required to prepare the *reserve equipment* for activation

Activation means *synchronising* the *reserve equipment* where required and increasing its output to the *firm capacity*.

Activation Lead Time means the maximum period required by the *Reserve Provider* to *activate* reserve in response to an *activation instruction*.

De-activation means reducing the output of the *reserve equipment* to the *network* as quickly as practicable until it is below its *market capacity* or is *de-synchronised*.

De-activation Lead Time means the maximum period required to *disable* the *reserve equipment*

Version release history

Version	Effective date	Summary of changes
6.1	24 October 2021	Minor update for wholesale demand response.
6	31 August 2020	Minor update for multi-year Victorian contracts.
5.1	16 April 2020	Minor update for multi-year Victorian contracts.
5.0	26 March 2020	Combined with the 'Procedure for the Exercise of Reliability and Emergency Reserve Trader' and renamed. Revised template. Updated to reflect rule change 'Enhancement to the Reliability and Emergency Reserve Trader' dated 2 May 2019. Redundant provisions from both Procedures removed.
4.0	9 June 2011	Revised template. Added disclaimer. Added <i>Affected Participants</i> and intervention pricing. Modified Management of Reserve Conditions.
3.0	30 November 2009	Interim Amendments.
2.0	22 May 2009	Version consistent with the final determination of <i>RERT</i> consultation.
1.0	17 February 2009	First Draft for Rule Consultation.