

APPROVED AMENDED PRICING METHODOLOGY FOR PRESCRIBED SHARED TRANSMISSION SERVICES FOR 1 JULY 2014 TO 30 JUNE 2019

DATE: 15 May 2015

Contents

1	Executive Summary	6
1.1	Introduction	6
1.2	Pricing Structure.....	6
1.2.1	Locational prices and charges	6
1.2.2	Non-locational prices and charges.....	7
1.2.3	Common transmission services prices and charges.....	7
1.3	Unavailable historical data.....	7
1.4	Exceptional circumstances	7
1.5	Over or under recovery	7
1.6	Duration of methodology	8
2	AEMO's responsibilities under Victorian arrangements.....	8
3	Pricing methodology.....	8
3.1	Background.....	8
3.2	Overview of the pricing methodology.....	8
3.3	Allocating the MAR.....	9
3.3.1	Cost allocation to service categories.....	9
3.3.2	Allocation of the prescribed TUOS category.....	9
3.3.3	Adjustment of the locational component and the non-locational component.....	9
3.4	Allocating the locational component to individual connection points	10
3.5	Calculating locational, non-locational and common service prices and charges.	11
3.5.1	Locational prices and charges for each connection point	11
3.5.2	Non-locational prices and charges for each connection point	12
3.5.3	Prescribed common transmission services prices and charges	13
4	Exceptional circumstances.....	13
5	Prudent discounts	13
6	Billing and financial transfers.....	13
6.1	Billing arrangements for inter-regional TUOS charging.....	13
6.2	Billing arrangements for transmission customers	13
6.3	Financial transfers.....	14
7	Prudential requirements	14
8	Derogations.....	14
9	Monitoring and compliance	15
10	Differences between current and final pricing methodology	15
11	Appendix A: Overview of AEMO's pricing methodology	16
12	Appendix B: TUOS worked example.....	17

12.1	Calculation of total annual service revenue requirements (ASRR) for prescribed TUOS services and prescribed common transmission services	17
12.1.1	DTSO component of ASRR	17
12.1.2	Additional assets	17
12.1.3	AEMO planning and procurement costs	18
12.1.4	Determine total ASRRs	18
12.2	Adjustment of locational component of prescribed TUOS services and allocation to connection points	18
12.2.1	Locational component and adjustments.....	18
12.2.2	Allocation to connection points.....	19
12.3	Determination of prices for locational component of prescribed TUOS services	19
12.3.1	Data requirements.....	19
12.3.2	Calculation of price.....	19
12.3.3	Price capping.....	20
12.4	Determination of charges for locational component of prescribed TUOS services	21
12.5	Determination of adjusted non-locational component of prescribed TUOS services and prices	21
12.5.1	Determine adjusted non-locational component.....	21
12.5.2	Calculation of non-locational prices	22
12.6	Determination of charges for adjusted non-locational component of prescribed TUOS services.....	23
12.7	Prices for prescribed common transmission services	24
13	Appendix C: Inter-regional TUOS charge.....	25
13.1	Allocating the MAR.....	25
13.2	Adjustment of locational component.....	26
13.3	MLEC.....	26
13.4	Timetable for provision of data	26
13.5	Billing arrangements with TNSPs within Victoria	26
13.6	Worked example of inter-regional TUOS charges	26
14	Appendix D: Application of equalisation adjustment.....	28

Important notice

This pricing methodology has been prepared by AEMO for the purposes of Part J of the National Electricity Rules, as modified by clause S6A.4.2(k). It has been approved by the AER in accordance with and for the purposes set out in the National Electricity Rules. The National Electricity Rules and the National Electricity Law will prevail over this document to the extent of any inconsistency.

© 2014 Australian Energy Market Operator Limited. The material in this document may be used in accordance with the [copyright permissions](#) on AEMO's website.

GLOSSARY

Unless the context otherwise requires, this document will be interpreted in accordance with Schedule 2 of the NEL.

TERM	MEANING
AARR	Aggregate Annual Revenue Requirement
Additional assets	Transmission assets that provide prescribed transmission services but are outside the asset owner's regulated asset base.
AER Guidelines	The AER's pricing methodology guidelines made under rule 6A.25 of the NER, effective from 31 October 2007.
ASRR	Annual Service Revenue Requirement
CAMD	Contract agreed maximum demand
CNSP	Co-ordinating Network Service Provider
Common transmission services price	Prescribed transmission services price as defined in the NER
CRNP	Cost reflective network pricing
DTS	Declared transmission system, as defined in the NEL.
DTSO	Declared transmission system operator, as defined in the NEL.
Financial year t	The financial year in which transmission prices being calculated are to apply
Financial year t+1	The financial year following the financial year t
Financial year t-2	The financial year two years prior to financial year t, which represents the most recent financial year where full historical data is available for pricing purposes
MAR	Maximum Allowed Revenue as defined in the NER
MLEC	Modified Load Export Charge
NEL	National Electricity Law.
NER	National Electricity Rules (version 55).
ORC	Optimised replacement cost
Revenue methodology	AEMO's Revenue Methodology for Victoria's Electricity Transmission System dated 11 July 2011, published under clause S6A.4.2(c) of the NER, effective from 1 July 2011.
SP AusNet	SPI PowerNet Pty Ltd, which is the DTSO for the major part of the declared transmission system.
TNSP	A Transmission Network Service Provider.

1 Executive Summary

1.1 Introduction

As part of its functions AEMO provides shared transmission network services to users of the Victorian Declared Transmission System (DTS). These services include the planning of future requirements and the procuring of augmentations in the DTS.

The costs which AEMO incurs in performing these functions (known as the Maximum Allowed Revenue (MAR)) are recovered by AEMO through charges to transmission customers. Most transmission charges are paid by distribution businesses, with some paid by large customers directly connected to the DTS. AEMO's MAR is calculated as detailed in AEMO's Revenue Methodology, which is published on AEMO's website.

The majority of AEMO's MAR is made up of the following:

- AER-determined regulated revenue of SP AusNet and Murraylink.
- Augmentations outside SP AusNet's and Murraylink's regulated asset base.
- AEMO's planning and procurement costs for the Victorian DTS.

This approved amended pricing methodology sets out how AEMO will recover its MAR for the 5 year regulatory period from 1 July 2014 to 30 June 2019. It has been developed in line with the requirements of the National Electricity Rules (NER) and the AER Pricing Methodology Guidelines (AER Guidelines) and the National Electricity Amendment (Inter-regional Transmission Charging) Rule 2013.

1.2 Pricing Structure

There are currently over 60 connection points in the Victorian DTS.

Every year, for each of these connection points, AEMO sets a:

- Locational price.
- Non-locational price.
- Common transmission services price.

These prices are based on the methodology detailed in this document. A summary of each price component and its related charge is provided below.

1.2.1 Locational prices and charges

The locational price is based on a cost reflective network pricing (CRNP) methodology and demand at times of greatest DTS utilisation for which network investment is likely to be contemplated.

The locational price is calculated on the basis of historical data or contract agreed maximum demand (CAMD).

If using the historical data basis to calculate locational prices AEMO will use the average of the transmission customer's half-hourly maximum demand recorded at a connection point on the 10 weekdays when system demand was highest between the hours of 11:00 and 19:00 in the local time zone during the most recently completed 12 month period (t-1), expressed as \$/MW. AEMO will consider the most recent 12 month period to be 1 March to 28 February.

The lower of CAMD and t-1 maximum demand will be used in the calculation of the locational price.

To calculate the locational charge for each connection point, the locational price is then multiplied by lower of the average maximum demand for the most recently completed 12 month period (t-1) and the CAMD (if the customer has elected to use a CAMD) at that connection point.

1.2.2 Non-locational prices and charges

Non-locational prices are calculated on a postage stamp basis which applies a uniform price [per MW] for all customers regardless of their system use.

The non-locational prices are determined so that a customer with a median load factor would be charged the same amount regardless of whether the CAMD price or a historical energy price is used, while ensuring that the maximum allowed revenue for this component is not exceeded.

Customers have the option of electing to use a contracted energy amount rather than historical energy for calculation of non-locational charges.

For customers with a CAMD, the customer will be charged the lower of:

- the price multiplied by the CAMD, or
- the price multiplied by the metered energy offtake at the connection point for the most recently completed 12 month period (t-1) (or the contracted energy amount if the customer has elected to use contracted energy).

For customers without a CAMD, the customer is charged the price multiplied by the metered energy offtake at the connection point for the most recently completed 12 month period (t-1). However if the customer has elected to use contracted energy the customer will be charged the price multiplied by the contracted energy.

1.2.3 Common transmission services prices and charges

Common transmission service prices are calculated on a postage stamp basis which applies a uniform price [per MW] for all customers regardless of their system use.

The common service price is calculated on the same basis as the non-locational price (detailed above), with the exception that this price is calculated to ensure that the MAR for the prescribed common transmission service is not exceeded.

1.3 Unavailable historical data

For locational TUOS, if historical average maximum demand data is unavailable and the customer does not elect to use a CAMD, then AEMO will use forecast average maximum demand data in its price calculations and forecast average maximum demand in its charge calculations.

After the end of the financial year t, once the actual average maximum demands for financial year t are known, the charges paid during the year will be adjusted such that the total annual locational TUOS charge is equal to the locational TUOS price multiplied by the actual average maximum demand for the financial year t.

For non-locational TUOS and common services, if historical metered energy offtake is unavailable, and the customer does not elect to use CAMD or contracted energy, then AEMO will use forecast energy offtake in its price calculations and current metered energy offtake in its charge calculations.

1.4 Exceptional circumstances

Under exceptional circumstances where a customer's load is likely to differ significantly from what was previously expected, the customer may request that AEMO consider charging the customer on the basis of actual data for the remainder of the current period (t).

1.5 Over or under recovery

The estimated balance of any over or under recovery in a year is carried forward and incorporated into following year's non-locational price and charge calculations.

1.6 Duration of methodology

This methodology is effective for a 5 year period from 1 July 2014 to 30 June 2019.

2 AEMO's responsibilities under Victorian arrangements

AEMO provides shared transmission services via the declared transmission system (DTS) in Victoria, and allocates the MAR for shared transmission services to connection points in the Victorian DTS.

Multiple transmission network service providers (TNSPs) provide shared network capability services to AEMO in Victoria.

These Transmission Network Service Providers (TNSPs) must advise AEMO annually of the aggregate annual revenue requirement for their part of the transmission system that is used to provide shared network capability services to AEMO.

AEMO then allocates (in accordance with this pricing methodology) the total aggregate annual revenue requirement of all TNSPs for each connection point.

3 Pricing methodology

3.1 Background

AEMO's existing pricing methodology was developed by VENCORP and approved by the AER in April 2008. It covers the period from 1 July 2008 to 30 June 2014. On 1 July 2009, all of VENCORP's rights, obligations and undertakings were assumed by AEMO. Under the National Electricity (Victoria) Act 2005, VENCORP's approved pricing methodology was deemed to be regarded as AEMO's pricing methodology.

This pricing methodology sets out how AEMO will allocate its maximum allowed revenue for prescribed shared transmission services for the 5 year regulatory period from 1 July 2014 to 30 June 2019. AEMO's maximum allowed revenue is calculated in accordance with AEMO's Revenue Methodology, which is published on AEMO's website.

The majority of AEMO's annual revenue requirement is made up of:

- AER determined regulated revenue of SP AusNet and Murraylink.
- Augmentations outside SP AusNet's and Murraylink's regulated asset base.
- AEMO's planning and procurement costs for the Victorian DTS.

3.2 Overview of the pricing methodology

Determining prescribed shared transmission service prices involves the following key steps:

1. Allocating the MAR:
 - Allocating the MAR to prescribed TUOS services and prescribed common transmission services.
 - Allocating prescribed TUOS services into pre-adjusted locational and pre-adjusted non-locational components.
 - Adjusting the pre-adjusted locational component to account for inter-regional residue auction revenue, Modified Load Export Charge (MLEC) and other adjustments.
 - Adjusting the pre-adjusted non-locational component to account for intra-regional settlement residue receipts, over or under recovery, any prudent discounts, and other adjustments.

2. Allocating the adjusted locational component to individual connection points based on CRNP methodology.
3. Calculating prices for the following:
 - Prescribed common transmission services.
 - Adjusted locational component of prescribed TUOS services.
 - Adjusted non-locational component of prescribed TUOS services.
4. Calculating charges for the following:
 - Prescribed common transmission services.
 - Adjusted locational component of prescribed TUOS services.
 - Adjusted non-locational component of prescribed TUOS services.

The Appendix provides an overview of the pricing process in a flowchart format.

Section 3.3-3.5 below describes each of the steps in further detail.

3.3 Allocating the MAR

3.3.1 Cost allocation to service categories

The first stage in calculating prescribed shared transmission service prices is to allocate prescribed TUOS services and prescribed common services with the costs of transmission system assets that are directly attributable to providing the relevant category of service.

SP AusNet and Murraylink, as regulated asset owners, provide sufficient information to AEMO so that AEMO can allocate the MAR for prescribed TUOS services and prescribed common services.

AEMO also recovers revenue for DTS assets that provide prescribed shared transmission services but are outside the asset owner's regulated asset base. These are charged according to a contract between AEMO and the asset owner. AEMO allocates these assets to the relevant service category in accordance with clauses 2.4(a)(3) and (4) of the AER Guidelines.

AEMO's planning and procurement costs for the Victorian DTS¹ are allocated to prescribed common services.

3.3.2 Allocation of the prescribed TUOS category

The NER sets out particular requirements for the allocation of MAR for prescribed TUOS services. The NER requires that the share of the MAR for prescribed TUOS services be allocated to transmission customers' DTS connection points in the form of both a locational and non-locational component.

In accordance with the NER, AEMO will allocate the MAR for prescribed TUOS services as follows:

- 50% to the locational component; and
- 50% to the non-locational component.

3.3.3 Adjustment of the locational component and the non-locational component

In line with NER requirements, AEMO will adjust the pre-adjusted locational component:

- By subtracting the estimated inter-regional settlement residue auction revenue;
- By subtracting or adding any further adjustments to the inter-regional settlement residue auction revenue consistent with 6A.23.3(f);

¹ Planning costs include connection costs that cannot be allocated to a defined user and do not include AEMO's national planning functions.

- By subtracting or adding the net MLEC receivable or payable by AEMO, where the MLEC is calculated consistent with the methodology in 6A.29A (see Appendix C);
- By subtracting or adding any further adjustments to the MLEC consistent with 6A.23.3(f).

In accordance with clause 11.64.4,

- for regulatory year 2015-16, adjustments for year t-1 and t-2 referred to in 6A.23.3(f) are zero.
- for regulatory year 2016-17, adjustments for year t-2 referred to in 6A.23.3(f) are zero.

In accordance with clause 6A.23.3(d), if the result of this adjustment yields a negative number, the adjusted locational component will be deemed to be zero and the absolute value of the negative amount will be subtracted from the pre-adjusted non-locational component.

The non-locational component is adjusted by:

- Any estimated intra-regional settlement residue receipts;
- Any over/under recovery of AEMO's MAR from a previous year;
- Any adjustments consistent with 6A.23.3(f);
- Any over/under recovery of AEMO's MAR as a result of applying the 2% price cap explained in section 3.5.1 below;
- Any under recovery as a result of applying any prudent discounts explained in section 5 below; and
- Any over/under recovery of AEMO's MAR as a result of the locational component being set to zero (explained above).

3.4 Allocating the locational component to individual connection points

In accordance with the NER, prices for the recovery of the MAR allocated to the locational component of prescribed TUOS services will be based on demand at times of greatest DTS utilisation for which network investment is most likely to be contemplated.

AEMO will use the CRNP methodology to allocate the locational component to connection points². The methodology estimates the proportionate use of the relevant transmission system assets by each transmission customer.

To allocate the locational component to connection points, the following input data will be used:

- An electrical loadflow model of the Victorian network that includes all committed augmentations in financial year t.
- A cost model detailing the optimised replacement cost (ORC) for each network element in the static model of the Victorian DTS in financial year t.
- Load and generation data for the 10 weekdays when system demand was highest between the hours of 11:00 and 19:00 in the local time zone during the most recent 12 months (t-1).
- CAMD amounts agreed with customers.

For modelling loads at connection points, if historical average maximum demand data is unavailable or only partially available AEMO will use a forecast average maximum demand instead. This is discussed in detail in section 3.5.1 below.

² AEMO uses the software package TPRICE which implements the CRNP methodology.

3.5 Calculating locational, non-locational and common service prices and charges.

3.5.1 Locational prices and charges for each connection point

Using the CRNP methodology in section 3.4 results in a lump sum dollar amount being recovered at each connection point.

In calculating the locational price to recover this lump sum, AEMO will use:

- The CAMD, if the customer has elected to use a CAMD, or
- the average of the transmission customer's half-hourly maximum demand recorded at a connection point on the 10 weekdays when system demand was highest between the hours of 11:00 and 19:00 in the local time zone during the most recently completed 12 month period (t-1). AEMO will consider the most recent 12 month period to be from 1 March to 28 February.

If historical average maximum demand data for the most recent 12 month period (t-1) is unavailable or only partially available for a connection point, forecast average maximum demand for the financial year t in which the locational prices will apply may be used instead. This forecast will be determined by AEMO in consultation with the relevant transmission customer and may be either a forecast average maximum demand for the financial year t at the new connection point or may involve the use of the CAMD as a proxy. This will be applicable for new connection points that will be commissioned in the financial year t in which the locational prices will apply, or for new connection points recently commissioned where historical average maximum demands in financial year t-1 is unavailable or only partially available.

The lump sum dollar amount is divided by the average maximum demand to calculate a locational price for each connection point, expressed as \$/MW.

As provided in the NER, prices for recovering the locational component of the MAR for prescribed TUOS services must not change by more than 2% per annum compared to the load-weighted average locational price for the Victorian region. This is subject to exceptions under clause 6A.23.4(b)(3). Any under or over recovery resulting from this price constraint will be recovered or offset (as appropriate) by adjusting the prescribed TUOS services non-locational prices and charges.

Under the AER Guidelines, the locational TUOS price calculated must be applied to a measure of actual, forecast or contract demand to derive the locational charge.

AEMO will charge transmission customers for the locational component by multiplying the locational TUOS price by the lower of:

- the CAMD, if the customer has elected to use a CAMD, and
- the actual average maximum demand for the most recent 12 month period (t-1) for their respective connection points.

If historical average maximum demand data for financial year t-1 is unavailable or only partially available for a connection point, AEMO will charge transmission customers for the locational component by multiplying the locational TUOS price by the actual average maximum demand for the financial year t for their respective connection points. This will be done in two steps.

- Initially transmission customers will be charged for the locational component by an amount equal to the locational TUOS price multiplied by the forecast average maximum demand for the financial year t.
- After the end of the financial year t, once the actual average maximum demands for financial year t are known, the charges paid during the year will be adjusted such that the total annual locational TUOS charge is equal to the locational TUOS price multiplied by the actual average maximum demand for the financial year t. Any over or under recovery in

financial year t as a result of this adjustment would be charged or reimbursed through non-locational prices in financial year $t+1$.

- Under exceptional circumstances where a customer's load is likely to differ significantly from what was previously expected, the customer may request that AEMO consider setting the customer's locational charge on the basis of actual data for the remainder of the current period (t).
- AEMO does not propose to recalculate the locational prices for financial year t in circumstances where load at a connection point(s) changes significantly after the locational prices for transmission customers in the Victorian region have been determined and published by AEMO for financial year t .

3.5.2 Non-locational prices and charges for each connection point

In accordance with the NER, prices for the recovery of the MAR allocated to the adjusted non-locational component of prescribed TUOS services will be set on a postage-stamp basis.

AEMO will calculate two prices for the recovery of the adjusted non-locational component of the MAR for prescribed TUOS services, namely:

- An energy-based price (\$/MWh); and
- A CAMD price (\$/MW).

These two prices will be calculated in such a way that a transmission customer with a load factor equal to the median load factor for connection points with transmission customers connected to the transmission network in the region would be indifferent to which of the two prices applies. The non-locational component prices will be the same for each exit point on the Victorian DTS and will be determined so that the total amount AEMO expects to recover from charges for the adjusted non-locational component does not exceed the adjusted non-locational component of the MAR for prescribed TUOS services.

The CAMD price will only be available to transmission customers who are party to a use-of -system agreement with AEMO which specifies a CAMD and penalties for exceeding the CAMD.

For customers with a CAMD, the customer will be charged the lower of:

- the price multiplied by the CAMD, or
- the price multiplied by the metered energy offtake at the connection point for the most recently completed 12 month period ($t-1$) (or the contracted energy amount if the customer has elected to use contracted energy).

Only the energy-based price will be available to transmission customers who do not have a use-of -system agreement with AEMO which specifies a CAMD and penalties for exceeding the CAMD.

Customers have the option of electing to use a contracted energy amount rather than historical energy for calculation of non-locational charges.

For customers without a CAMD, the customer is charged the price multiplied by the metered energy offtake at the connection point for the most recently completed 12 month period ($t-1$). However if the customer has elected to use contracted energy the customer will be charged the price multiplied by the contracted energy.

If historical metered energy offtake for the most recent 12 months ($t-1$) is unavailable or only partially available for a connection point, forecast energy offtake for the financial year t may be used instead. This forecast will be determined by AEMO in consultation with the relevant transmission customer. This will be applicable for new connection points that will be commissioned in the financial year t in which the non-locational prices will apply, or for new connection points recently commissioned where historical metered energy offtake for the most recent 12 months ($t-1$) is unavailable or partially available.

Under exceptional circumstances where a customer's load is likely to differ significantly from what was previously expected, the customer may request that AEMO consider setting the customer's non-locational charge on the basis of actual data for the remainder of the current period (t).

3.5.3 Prescribed common transmission services prices and charges

In accordance with the NER, prices for the recovery of the annual revenue requirement allocated to the prescribed common transmission services will be set on a postage-stamp basis.

AEMO will develop prices and charges for prescribed common transmission services in a method similar to that used to develop prices for the adjusted non-locational component of the MAR for prescribed TUOS services.

4 Exceptional circumstances

Under exceptional circumstances where a customer's load is likely to differ significantly from what was previously expected, the customer may request that AEMO consider charging the customer on the basis of actual data for the remainder of the current period (t).

AEMO will consider requests on a case by case basis. Examples of situations where the use of forecast average maximum demand may be appropriate include:

- The transfer of significant amounts of load to/from connection points.
- The commissioning/decommissioning of significant amounts of load.
- The highly variable nature of load, results in significant deviations between historical average maximum demand and forecast average maximum demand.

5 Prudent discounts

AEMO may, but is not required to, agree with a transmission customer to charge lower prices for prescribed TUOS services and prescribed common transmission services than the prices determined in accordance with this pricing methodology.

AEMO notes that none of its transmission customers currently receive prudent discounts as at the date of the pricing methodology publication.

In the event that a transmission customer does receive prudent discounts in the future, AEMO will adjust the non-locational component of the prescribed TUOS services and the prescribed common services prices to other customers for the amount of the estimated under recovery arising from that discount.

6 Billing and financial transfers

6.1 Billing arrangements for inter-regional TUOS charging

In accordance with clause 6A.29A.4, AEMO will:

- issue invoices for MLEC to co-ordinating network service providers (CNSP) for each interconnected region, as equal monthly instalments; and
- Pay invoiced MLEC to CNSPs for each interconnected region.

6.2 Billing arrangements for transmission customers

AEMO will issue monthly invoices to transmission customers. These will contain at least the minimum information requirements specified in clause 6A.27.2 of the Rules.

Transmission customers must pay charges for prescribed transmission services properly charged and billed in accordance with this pricing methodology by the date specified on the invoice. Charges for locational TUOS will include adjustments for net MLEC either payable or receivable by AEMO.

6.3 Financial transfers

AEMO will pay to each relevant TNSP the revenue it collects for charges for the prescribed transmission services provided by assets owned by those TNSPs. This revenue will be inclusive of net MLEC receivable by AEMO from other CNSPs of interconnected regions.

These financial transfers will be paid in accordance with the Rules and as per agreements negotiated between the parties.

7 Prudential requirements

Under the NER, AEMO may require a transmission customer to establish prudential requirements for either or both connection services and TUOS. These prudential requirements may take the form of, but need not be limited to, capital contributions, prepayments or financial guarantees.

In the event that a capital contribution or prepayment is required, any contribution will be taken into account in determining prescribed transmission service prices in a manner negotiated between the parties and in all cases in accordance with the relevant provisions of the Rules.

8 Derogations

Under clause 2.1(o) of the AER Guidelines, AEMO's pricing methodology must include details of any derogations in accordance with Chapter 9 of the NER.

Clause 9.8.4 requires that in determining transmission service pricing and revenues, the AER must ensure that each Distributor has the benefit or burden of an equalisation adjustment for each financial year as shown in Table 1, multiplied by the relevant factor as shown in Table 2:

Table 1

Business	Equalisation Adjustment (\$'000) Note 2)
SPI Electricity	(4,939)
Powercor Australia Ltd	(19,011)
Jemena	5,171
CitiPower Pty Ltd	5,920
United Energy Ltd	12,859

Table 2

If the financial year falls within the period:	then the relevant factor is:
1 July 2010 - 30 June 2015	.40
1 July 2015 - 30 June 2020	.20
Thereafter	0

AEMO must, in allocating revenue to be recovered from each Distributor to which it provides prescribed TUOS services and prescribed common transmission services by means of, or in connection with a declared shared network in each financial year of a relevant regulatory period, adjust the allocation in accordance with paragraph (b) above.

9 Monitoring and compliance

In accordance with clause 6A.24.2 of the NER, AEMO will publish a current copy of its approved pricing methodology on its website. In addition, in accordance with clause 6A.16 as modified by clause S6A.4.2(f), AEMO will publish its prescribed shared transmission service prices for each regulatory year on AEMO's website by the preceding 15 May. In accordance with clause 6A.24.2(b), AEMO will publish details of all MLEC by the preceding 15 March.

10 Differences between current and final pricing methodology

AEMO's pricing methodology differs from the pricing methodology for the period 1 July 2008 to 30 June 2014 as set out below:

- This pricing methodology reflects AEMO's assumption of certain functions and powers previously conferred on VENCORP.
- This pricing methodology reflects changes to the NER that have occurred since the approval of the current pricing methodology.

AEMO has identified differences between the current and approved pricing methodology, and the current process actually used by AEMO to determine transmission customer prices and charges:

- The current and new methodologies require AEMO to use historical average maximum demand data to calculate both locational prices and charges. While AEMO has used historical average maximum demand data to calculate locational prices, AEMO has in practice used forecast average maximum demand data rather than historical average maximum demand data in calculating locational charges for all connection points.
- Additionally, AEMO conducted a reconciliation process to compare charges to transmission customers based on actual average maximum demands in the current year from 1 November to 31 March with locational charges based on forecast average maximum demands. Any variances as a result of this reconciliation were reimbursed to, or recovered from, transmission customers in the current financial year, with any over or under recovery in financial year t as a result of this being addressed through non-locational prices in financial year $t+1$.

11 Appendix A: Overview of AEMO's pricing methodology

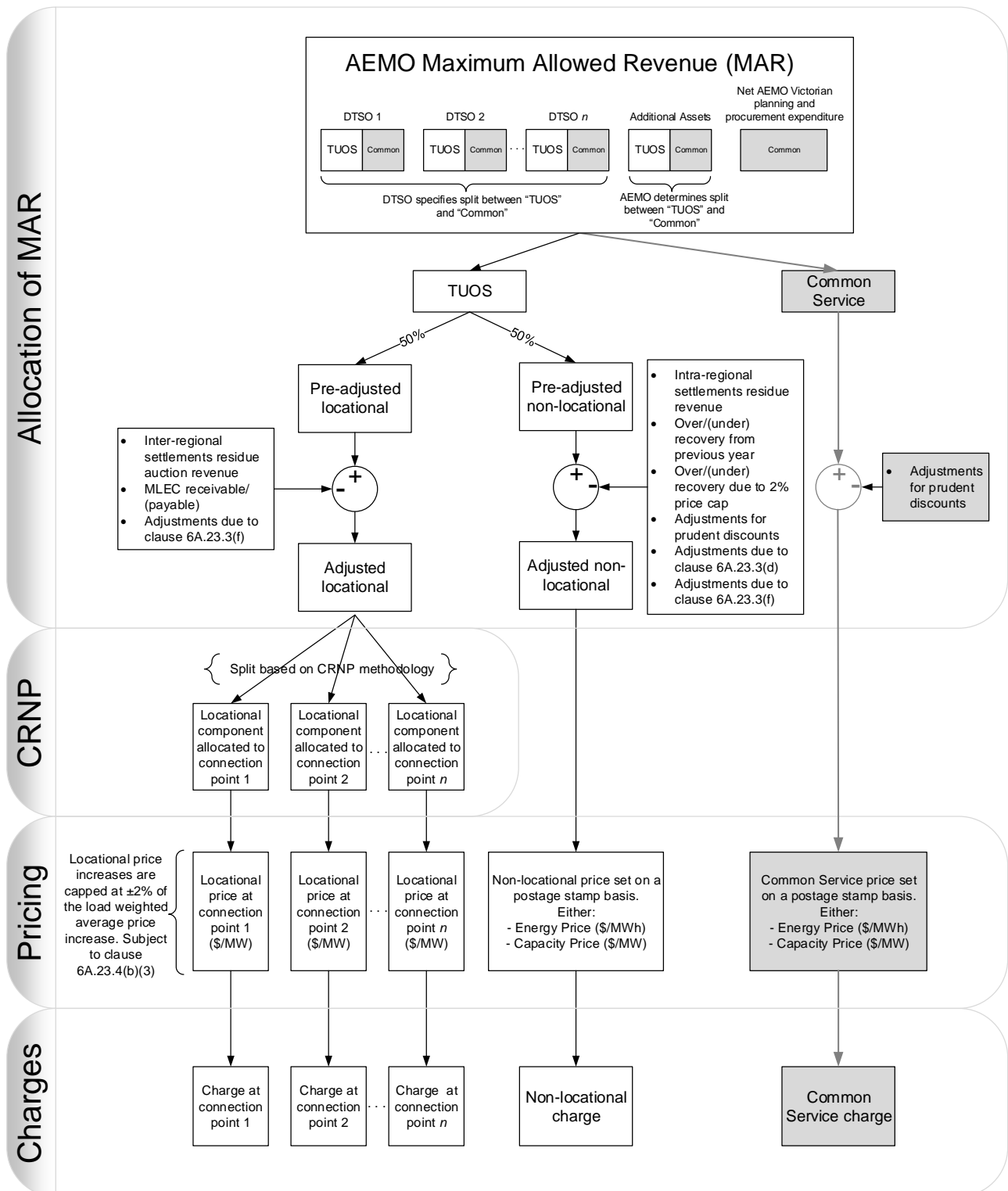

Figure 1: Overview of TUOS Pricing Methodology

12 Appendix B: TUOS worked example

12.1 Calculation of total annual service revenue requirements (ASRR) for prescribed TUOS services and prescribed common transmission services

Assume a simple power system as depicted by figure Figure 2 below consisting of two generators and four transmission customer connection points with loads 1 to 4.

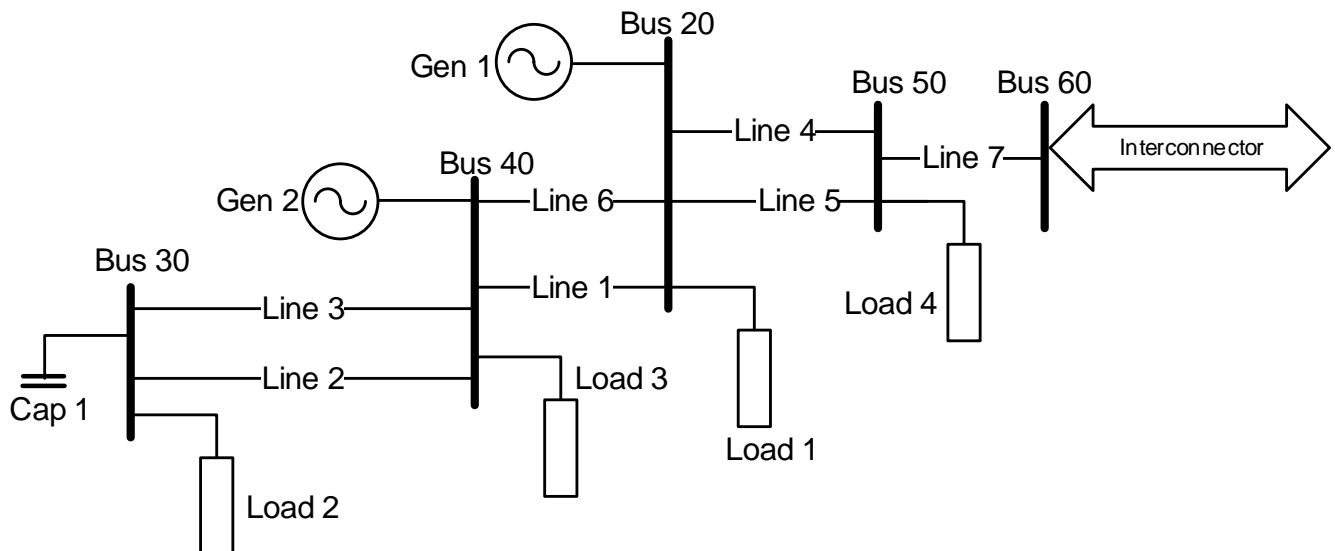

Figure 2: Simple power system

Also assume that at bus 60, the network is interconnected to a transmission network of another interconnected region.

12.1.1 DTSSO component of ASRR

Assume a single DTSSO in the region. The DTSSO notifies AEMO of the DTSSO's ASRRs and its operating and maintenance costs incurred in the provision of prescribed common transmission services. Assume the following:

- The DTSSO's ASRR for prescribed TUOS services is \$20m.
- The DTSSO's ASRR for prescribed common transmission services is \$10.7m.

12.1.2 Additional assets

In the sample power system depicted in figure 2 above, the following network elements are additional assets; they provide shared network services that are operated and maintained by the DTSSO under additional network service agreements with AEMO, the costs of which are not included in the determination of the DTSSO's aggregate annual revenue requirement (AARR):

- Line 1, between Bus 20 and Bus 40.
- Line 3, between Bus 30 and Bus 40.
- Capacitor 1, at Bus 30.

As the costs of these network elements are not reflected in the DTSO's AARR, AEMO will allocate each of these additional assets to either the prescribed TUOS services or prescribed common transmission services categories of prescribed transmission services, with charges as per the additional network service agreements. Assume the charges are allocated as in Table 3 below.

Table 3: Annual service charges for additional assets

Additional assets	Allocation to category of prescribed transmission services	Annual service charge (\$m)
Line 1	Prescribed TUOS services	8.7
Line 3	Prescribed TUOS services	10.045
Capacitor 1	Prescribed common transmission services	1.8

12.1.3 AEMO planning and procurement costs

Assume that AEMO's net annual Victorian planning and procurement cost is \$1.5m.

12.1.4 Determine total ASRRs

AEMO then sums the prescribed TUOS services and prescribed common transmission services categories to arrive at the total Victorian ASRRs as follows:

Table 4: Total ASRRs for Victorian region

Category of prescribed transmission services	DTSO's ASRR (\$m)	Additional assets (\$m)	AEMO's Victorian planning and procurement (\$m)	Total ASRRs for Victorian region (\$m)
Prescribed TUOS services	20	18.745		38.745
Prescribed common transmission services	10.7	1.8	1.5	14

12.2 Adjustment of locational component of prescribed TUOS services and allocation to connection points

12.2.1 Locational component and adjustments

AEMO then calculates the pre-adjusted locational component of the prescribed TUOS service as 50% of the ASRR for prescribed TUOS services (\$38.745m from Table 4), and adjusts this with the inter-regional settlement residue auction revenue, and net MLEC under clause 6A.29A.5. Assume

- Zero inter-regional settlement residue auction revenue;
- \$1.5m of MLEC payable by AEMO to the CNSP of the interconnected region; and
- \$0.5m of MLEC receivable by AEMO from the CNSP of the interconnected region. Further details of this calculation can be found in appendix C.

Therefore, the net MLEC is \$1m payable by AEMO, and is added to calculate the adjusted locational component.

- Adjusted locational component = \$20.373m ($\$38.745m \times 50\% + \$1m$ due to net MLEC payable by AEMO)

12.2.2 Allocation to connection points

The CRNP methodology simultaneously allocates the locational component of the ASRR for prescribed TUOS services to transmission customer's connection points in the network.

An example result of how the locational component of the ASRR for prescribed TUOS services as determined by the CRNP methodology for year t is set out in Table 5 below.

Table 5: Locational cost allocation in year t

Load	Bus Name	Proportional split from CRNP	Allocation not considering MLEC (\$m)	Allocation due to MLEC (\$m)
1	Bus 20	34.69%	6.720	0.347
2	Bus 30	5.87%	1.138	0.059
3	Bus 40	9.41%	1.823	0.094
4	Bus 50	50.03%	9.692	0.500
Total			19.373	1.000
Adjusted location component			20.373	

That is, CRNP methodology produces a locational cost allocation for each connection point in the network in year t. The sum of all these locational cost allocations is the locational component of the ASRR for prescribed TUOS services, which is \$20.373m for year t.

12.3 Determination of prices for locational component of prescribed TUOS services

12.3.1 Data requirements

The following data is required for calculating prices for recovery of the locational component of the ASRR for prescribed TUOS services in year t:

- The locational cost allocation for each connection point with a transmission customer in the DTS for year t as in Table 5; and
- The average maximum demands and CAMD for each of those connection points in year t-1 set out in Table 6 below.

Table 6: Allocated locational cost and average maximum demand

Load	Bus name	Allocation not considering MLEC (\$m) in year t	Allocation due to MLEC (\$m) in year t	Average maximum demand (MW) in year t-1	CAMD (MW)
1	Bus 20	6.720	0.347	686.27	n/a
2	Bus 30	1.138	0.059	245.10	n/a
3	Bus 40	1.823	0.094	245.10	n/a
4	Bus 50	9.692	0.500	294.12	300.0

12.3.2 Calculation of price

Locational prices are capped as specified in clause 6A.23.4(b)(2). However clause 6A.23.4(b)(3)(i) specifies that price capping is not applicable to the extent that the change in prices relates to the MLEC. In order to fulfil both requirements, the price component with and without the influence of MLEC is calculated, and only the price component that is not influenced by MLEC is capped.

The uncapped price for each connection point for recovery of the locational component can now be calculated. This is done by dividing the allocated cost in year t for each connection point by the average maximum demand in year t-1 for that connection point. Note that for load 4 at bus 50,

since the t-1 average maximum demand is less than the CAMD, the t-1 average maximum demand is used to calculate the locational component.

The resulting uncapped prices in year t for recovery of the locational component of the ASRR for prescribed TUOS services are set out in Table 7 below.

Table 7: Uncapped prices for locational component in year t

Load	Bus name	Average maximum demand (MW) in year t-1	Allocation not considering MLEC (\$m) in year t	Allocation due to MLEC (\$m) in year t	Uncapped price	
					Price component not considering MLEC (\$/MW) in year t	Price component due to MLEC (\$/MW) in year t
1	Bus 20	686.27	6.720	0.347	9,792	506
2	Bus 30	245.10	1.138	0.059	4,643	241
3	Bus 40	245.10	1.823	0.094	7,438	384
4	Bus 50	294.12	9.692	0.500	32,953	1700

12.3.3 Price capping

It is necessary to limit the annual changes in prices for the adjusted locational component established by clause 6A.23.4(b)(2) of the NER (cap), excluding the price changes due to the influence of MLEC. The cap requires that the load weighted average price for the locational component in year t does not change by more than 2% per annum relative to year t-1. This calculation for the prices derived in Table 7 is listed in Table 8 below.

Table 8: Uncapped price change calculation.

Load	Year t-1		Year t		Price change (%)
	Average maximum demand (MW) in year t-2	Location al price (\$/MW)	Average maximum demand (MW) in year t-1	Uncapped price component not considering MLEC (\$/MW)	
1	676	7,751	686.27	9,792	26.3
2	245	4,400	245.10	4,643	5.5
3	245	5,962	245.10	7,438	24.8
4	300	27,500	294.12	32,953	19.8

- Annual load weighted average for year t-1 = \$10,932.
- Annual load weighted average for year t = \$13,174.
- Therefore, the annual load weighted change = 20.5%.
- By applying clause 6A.23.4(b)(2), the locational price change (excluding the price changes due to the influence of MLEC) should be constrained to 20.5% ± 2% i.e. 18.5% to 22.5%. From the last column of Table 8, it can be observed that Loads 1, 2 and 3 have breached these limits and need to be capped at 22.5%, 18.5% and 22.5% respectively. Load 4 is within the cap and would remain unchanged. Final prices are calculated by adding the capped locational price component with the uncapped price component due to MLEC. The results are shown in Table 9 below.

Table 9: Capped price change calculation

Load	Year t-1		Year t				
	Average maximum demand (MW) in year t-3	Locational price (\$/MW)	Average maximum demand (MW) in year t-2	Capped locational price component		Uncapped price component due to MLEC (\$/MW)	Final capped locational price (\$/MW)
				(\$/MW)	Change (%)		
1	676	7,751	686.27	9,493	22.5	506	9,999
2	245	4,400	245.1	5,215	18.5	241	5,456
3	245	5,962	245.1	7,305	22.5	384	7,689
4	300	27,500	294.12	32,953	19.8	1700	34,653

12.4 Determination of charges for locational component of prescribed TUOS services

The charge for each connection point for recovery of the locational component can now be calculated. This is done by multiplying the capped price in year t (calculated in Table 9) for each connection point by the average maximum demand in year t-1 for that connection point. This is shown in Table 10 below.

Table 10: Locational charge

Load	Year t		Locational charge (\$m)
	Average maximum demand (MW) in year t-1	Final capped locational price (\$/MW)	
1	686.27	9,999	6.862
2	245.1	5,456	1.337
3	245.1	7,689	1.885
4	294.12	34,653	10.192

The total charge for the locational component of the prescribed TUOS services is \$20.276m. This differs from \$20.373m, which is the total locational charge after adjustments (calculated in section 12.2 above). This difference is due to the price capping process, and the shortfall will be recovered in the non-locational component of prescribed TUOS services as explained in section 12.5 below.

12.5 Determination of adjusted non-locational component of prescribed TUOS services and prices

12.5.1 Determine adjusted non-locational component

AEMO then calculates the pre-adjusted non-locational component of the prescribed TUOS service as 50% of the ASRR for prescribed TUOS services (\$38.745m from table 4). Therefore:

- Prescribed TUOS services (pre-adjusted non-locational) = \$19.373m

To calculate the adjusted non-locational component, AEMO must make adjustments for:

- The amount of any over or underrecovery of the ASRRs for prescribed TUOS services and prescribed common transmission services in previous years.

- Intra-regional settlement residue revenue.
- Any prudent discount.
- The amount of any anticipated under-recovery by reason of the cap on the annual change in prices for the recovery of the locational component.
- Adjustments due to clause 6A.23.3(f).

Assume that after these adjustments are applied, the resultant adjusted non-locational component of the ASRR for prescribed TUOS services is \$15.373m.

12.5.2 Calculation of non-locational prices

To calculate the two prices for adjusted non-locational component of prescribed TUOS services in year t, namely the energy-based price and the CAMD price, the historical metered energy offtake data for each transmission customer's connection point set out in Table 11 below is required.

Table 11: Individual connection point CAMD and historical metered energy offtake

Load	Bus name	CAMD (MW)	Average maximum demand (MW) in year t-1	Historical metered energy offtake (GWh) in year t-1
1	Bus 20	n/a	686.27	3250.0
2	Bus 30	n/a	245.10	1100.0
3	Bus 40	n/a	245.10	900.0
4	Bus 50	300.0	294.12	1500.0
Total				6750.0

Note that only a few transmission customers have entered into an agreement with AEMO which specifies the level of CAMD. To calculate the energy-based price and the CAMD price for prescribed common transmission services, it is necessary to identify the median load factor customer and its CAMD. Since the majority of transmission customers do not have CAMDs, average maximum demands in year t-1 are used for transmission customers for the purpose of determining the median load factor customer where there is no defined CAMD for the transmission customer.

The energy-based price and the CAMD price for the recovery of the adjusted non-locational component of the ASRR for prescribed TUOS services are then calculated by solving the following representative simultaneous equations:

$$(AB_{t-1} \times PNLe_t) + (CCMD_t \times PNLc_t) = NLC_t \quad (1)$$

and

$$(ME_{t-1} \times PNLe_t) = (MMD_t \times PNLc_t) \quad (2)$$

where:

- AB_{t-1} = total annual billable energy (MWh) in year t-1 for all connection points in which the energy based price for recovery of the adjusted non-locational component applies in year t
- $PNLe_t$ = adjusted non-locational component energy based price in year t
- $CCMD_t$ = sum of CAMDs for all connection points at which the CAMD price for recovery of the adjusted non-locational component applies in year t
- $PNLc_t$ = adjusted non-locational component CAMD price in year t
- NLC_t = adjusted non-locational component in year t

ME_{t-1} = median load factor customer's historical metered energy offtake in year t-1

MMD_t = median load factor customer's average maximum demands in year t-1

Using the known values of AB_{t-1} , NLC_t , ME_{t-1} , $CCMD_t$ and MMD_t , the equations (1) and (2) above are solved simultaneously to determine the unknowns:

- Energy based price, i.e. $PNLe_t$; and
- CAMD Price, i.e. $PNLc_t$.

In this example, the median load factor customer is Load 1. Therefore the solution of the following two simultaneous equations leads to the energy-based price and the CAMD Price for the adjusted non-locational component of prescribed TUOS services in year t.

$$(3250 + 1100 + 900) \times 10^3 \times PNLe_t + 300 \times PNLc_t = \$15.373m$$

$$3250 \times 10^3 \times PNLe_t = 686.27 \times PNLc_t$$

The result is:

$$PNLc_t = \$10,914/MW$$

$$PNLe_t = \$2.30/MWh$$

12.6 Determination of charges for adjusted non-locational component of prescribed TUOS services

The charge for each connection point for recovery of the adjusted non-locational component can now be calculated. This is done by multiplying the prices in year t calculated above for each connection point by the historical metered energy offtake in year t-1 or the CAMD for that connection point (if it results in a lower charge). This is shown in Table 12 below.

Table 12: Adjusted non-locational charge

Load	Year t				Non-locational charge (\$m)
	Historical metered energy offtake (GWh) in year t-1	Energy based price (\$/MWh)	CAMD (MW)	CAMD price (\$/MW)	
1	3250.0	2.30	n/a		7.475
2	1100.0	2.30			2.530
3	900.0	2.30			2.070
4	n/a since a lower charge is obtained with the use of CAMD		300.0	10,914	3.274

The total charge for the adjusted non-locational component of the Prescribed TUOS Services is \$15.349m. This is different from \$15.373m in section 12.5.1 above due to the effect of rounding prices.

12.7 Prices for prescribed common transmission services

The prices for Prescribed Common Transmission services are derived in a substantively similar method to that set out above in respect of charges for the adjusted non-locational component of prescribed TUOS services, the only difference being that in this example, NLC_t should be substituted with the value \$14m which is the ASRR for Prescribed Common Transmission Services as calculated in Table 4 above. The prices $PNLe_t$ and $PNLc_t$ will then be the prescribed common transmission services energy based price in year t, and prescribed common transmission services CAMD price in year t respectively.

13 Appendix C: Inter-regional TUOS charge

Inter-regional transmission charging arrangements provide a mechanism for exporting regions in an inter-connected system to charge importing regions a MLEC for facilitating the transport of electricity.

AEMO is the CNSP in Victoria, and is responsible for calculation, allocation and billing of MLEC to or from CNSPs in interconnected regions to each TNSP within Victoria. This is done in accordance with clause 6A.29A.

An overview of the calculation of MLEC is shown in figure 3 below.

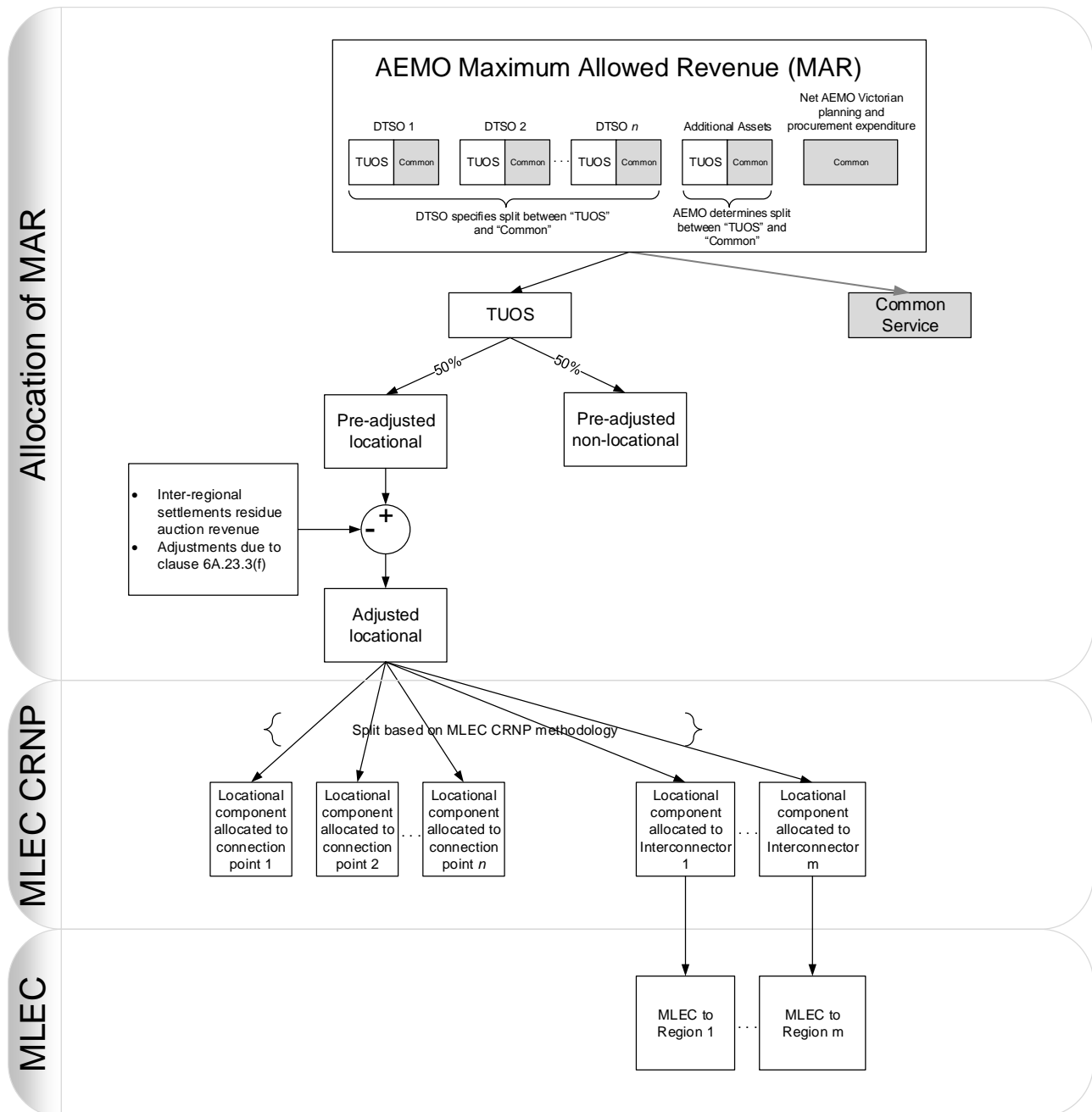

Figure 3: Overview of Inter-regional TUOS Charge

13.1 Allocating the MAR

The MAR is allocated to prescribed TUOS as described in section 3.3.1. In accordance with 6A.29A.2, 50% of prescribed TUOS is allocated to the pre-adjusted locational component.

13.2 Adjustment of locational component

In line with clause 6A.29A.2(a)(2), AEMO will calculate the adjusted locational component by adjusting the pre-adjusted locational component:

- By subtracting the estimated inter-regional settlement residue auction revenue;
- For any adjustments to the inter-regional settlement residue auction revenue consistent with 6A.23.3(b)(1);
- For any adjustments consistent with 6A.23.3(f).

13.3 MLEC

As required by clause 6A.29A.2(a)(3), AEMO will use the MLEC CRNP methodology to allocate the adjusted locational component to connection points of transmission customers and interconnected regions on the basis of their proportional use of the transmission system assets. The MLEC CRNP methodology is applied to data sourced from the previous completed financial year.

The MLEC for an interconnected region is determined to be the amount allocated to each interconnected region.

13.4 Timetable for provision of data

AEMO will calculate and publish the MLEC according to the following timetable:

- Exchange input data with TNSPs of interconnected regions – 1st week of January
- Publish MLEC on AEMO's website – 15 March
- Publish Victorian TUOS Prices on AEMO's website – 15 May

13.5 Billing arrangements with TNSPs within Victoria

In accordance with clause 6A.29A.5, AEMO as the CNSP in Victoria will allocate net receivable or payable MLEC to Victorian TNSPs on the basis of intra-regional network utilisation by applying the MLEC CRNP methodology. AEMO will also issue a bill to each TNSP for the net MLEC payable or receivable.

On behalf of Victorian TNSPs, AEMO is responsible for charging transmission customers with TUOS charges that include adjustments for net MLEC. AEMO will also pay or receive MLEC from CNSPs of interconnected regions.

In practice, TNSPs will receive their aggregate annual revenue, and there is no separate net MLEC amount to be transferred between AEMO and the TNSPs. The allocation and billing of net MLEC to TNSPs is solely for information purposes and to satisfy clause 6A.29A.5.

13.6 Worked example of inter-regional TUOS charges

This example is based on the same scenario described in section 12. In terms of the chronological order of performing calculations, the calculations in appendix C are done prior to those in appendix B since the MLEC is required to be published by 15 March.

- As in section 12.1.4, the ASRR for prescribed services is \$38.745m.
- Assuming inter-regional settlement residue auction revenue and other adjustments are zero, the adjusted locational component is 50% of \$38.745m, which is \$19.373m.
- Based on the MLEC CRNP methodology, assume that the adjusted locational component is split according to the percentages in column 3 of table 13. Then the allocated amounts to the connection points and the interconnector is listed in column 4.

Table 14: MLEC CRNP results

Load/Interconnector	Bus Name	Proportional split from MLEC CRNP	Allocation (\$m)
Load 1	Bus 20	33.79%	6.547
Load 2	Bus 30	5.72%	1.108
Load 3	Bus 40	9.17%	1.776
Load 4	Bus 50	48.74%	9.442
Interconnector	Bus 60	2.58%	0.500
Adjusted location component			19.373

- MLEC charged to the CNSP of the interconnected region is \$0.5m.
- Clause 6A.29A.5 requires AEMO as the CNSP to allocate and bill Victorian TNSPs with net MLEC charges.
 - Assume that there are two TNSP in the region, A and B, and:
 - Loads 1 and 2 are in the network of TNSP A;
 - Loads 3 and 4 are in the network of TNSP B; and,
 - \$1.5m of MLEC is payable by AEMO to CNSPs of interconnected regions (see section 12.2.1).
 - Net MLEC payable by AEMO is \$1m (\$1.5m - \$0.5m)
 - From table 14,
 - allocation to TNSP A as a percentage of all loads is 40.56%
 - allocation to TNSP B as a percentage of all loads is 59.44%
 - MLEC allocated and billed is
 - \$0.4056m payable by TNSP A (\$1m × 40.56%)
 - \$0.5944m payable by TNSP B (\$1m × 59.44%)

14 Appendix D: Application of equalisation adjustment

In the financial year 2014–15, the relevant factor set out in the second table appearing in rule 9.8.4(a)(3) of the current NER (set out in section 8 above) is 0.40. Accordingly, to determine the equalisation adjustment for each distributor for the 2014–15 financial year, AEMO will multiply the equalisation adjustment amount set out in the first table appearing in rule 9.8.4(a)(3) (also set out in section 8 above) for that distributor by 0.40. For example, for SPI Electricity, the equalisation adjustment for financial year 2014/15 is calculated as follows: $-\$4,939,000 \times 0.4 = -\$1,975,600$.

The resultant equalisation adjustments for each distributor for the 2014/15 financial year are set out in table 14 below.

Table 14: Equalisation adjustments for 2014/15

Distribution Business	Equalisation Adjustment (\$ per annum)		
	Exclusive of GST	GST	Total
SPI Electricity	-\$1,975,600	-\$197,560	-\$2,173,160
Powercor Australia	-\$7,604,400	-\$760,440	-\$8,364,840
Jemena	\$2,068,400	\$206,840	\$2,275,240
CitiPower	\$2,368,000	\$236,800	\$2,604,800
United Energy	\$5,143,600	\$514,360	\$5,657,960

The equalisation adjustments set out in Table 14 above are then divided by 12 to determine the monthly equalisation adjustment for 2014/15 for each distributor. For example, for SPI Electricity, the monthly equalisation adjustment for the 2014/15 financial year is calculated as follows: $-\$2,173,160 / 12 = -\$181,097$.

Each distributor's aggregate Prescribed TUOS Service and Prescribed Common Transmission Service charges in each month of the 2014/15 financial year will then be grossed up or reduced by that distributor's monthly equalisation adjustment for that financial year.