

# Commissioning Guideline

To support compliance with National Electricity Rules 5.8 requirements for commissioning of generating systems, integrated resource systems and synchronous condensers

**Prepared by:** AEMO Onboarding and Connections

---

**Version:** 1

---

**Effective date:** 28 January 2026

---

**Status:** FINAL

---

**Rules guideline:** No

---

## Approved for distribution and use by:

**Approved by:** Nicola Falcon

---

**Title:** Executive General Manager System Design

---

**Date:** 28 January 2026

---

[aemo.com.au](https://aemo.com.au)

New South Wales | Queensland | South Australia | Victoria | Australian Capital Territory | Tasmania | Western Australia

Australian Energy Market Operator Ltd ABN 94 072 010 327

# Important notice

## Purpose

AEMO has prepared this document to provide information and guidance for Proponents and NSPs on the process for commissioning of generating systems, integrated resource systems and synchronous condensers (schedule 5.2 plant) connected to the National Electricity Market power system. It is intended to support stakeholders in meeting applicable requirements for commissioning under National Electricity Rules 5.8.

## Disclaimer

The contents of this document are current at the date of publication and may be subsequently updated or amended. This document does not constitute technical, legal or business advice, and should not be relied on as a substitute for obtaining detailed advice about the National Electricity Law, the National Electricity Rules, or any other applicable laws, procedures or policies. AEMO has made reasonable efforts to ensure the quality of the information in this document but cannot guarantee its accuracy or completeness.

Accordingly, to the maximum extent permitted by law, AEMO and its officers, employees and consultants involved in the preparation of this document:

- make no representation or warranty, express or implied, as to the currency, accuracy, reliability or completeness of the information in this document; and
- are not liable (whether by reason of negligence or otherwise) for any statements or representations in this document, or any omissions from it, or for any use or reliance on the information in it.

## Copyright

© 2026 Australian Energy Market Operator Limited. The material in this publication may be used in accordance with the [copyright permissions on AEMO's website](#).

## Contents

<b>Current version release details</b>	<b>4</b>
<b>1. Introduction</b>	<b>5</b>
1.1. Purpose and scope	5
1.2. Abbreviations and definitions	5
1.3. Related documents	7
1.4. How to use this document	7
<b>2. Commissioning framework</b>	<b>8</b>
2.1. Commissioning process	8
2.2. Key principles	13
<b>3. Test categorisation</b>	<b>16</b>
3.1. Preliminary tests	17
3.2. Checkpoints	18
3.3. Hold points	19
3.4. Flexible tests	22
<b>4. Developing a commissioning program</b>	<b>23</b>
4.1. Contents of a commissioning program	23
4.2. Commissioning test structure	25
4.3. Hybrid systems	27
4.4. Plant alterations and testing settings changes	28
<b>5. Undertaking commissioning</b>	<b>28</b>
5.1. Pre-requisites for undertaking commissioning	28
5.2. Pre-test simulations	29
5.3. Measurement equipment	30
5.4. Commissioning communication and test details schedule	30
5.5. Witnessing of tests	32
5.6. Test day reporting requirements	33
5.7. Additional reporting requirements to finalise commissioning	33
5.8. Managing changes during commissioning	34
5.9. Managing adverse security impacts and non-compliances during commissioning	35
<b>Appendix A. Examples of default test categorisation</b>	<b>38</b>
<b>Appendix B. Example risk assessment</b>	<b>44</b>
<b>Appendix C. Example measurement point layout</b>	<b>46</b>

## Tables

Table 1	Preliminary tests.....	38
Table 2	Checkpoint tests .....	40
Table 3	Hold point tests .....	40

Table 4 Flexible tests .....42

Table 5 Risk matrix example.....44

Table 6 Risk assessment example – voltage reference step test .....44

Table 7 Risk controls example – voltage reference step test.....44

Table 8 Risk assessment example – partial generating system trip test .....45

Table 9 Risk controls example – partial generating system trip test .....45

## Figures

Figure 1 High level commissioning process .....9

Figure 2 Test categories.....17

Figure 3 Measurement point layout example .....46

## Current version release details

Please check AEMO’s website to confirm you are using the latest version of this Guideline.

Version	Document date	Summary of changes
1	28 January 2026	First version

# 1. Introduction

## 1.1. Purpose and scope

This “Commissioning Guideline” (Guideline) is to help Registered Participants (Proponents) connecting new or replacement equipment to the National Electricity Market (NEM) to meet applicable requirements for commissioning under National Electricity Rules (NER) 5.8. This Guideline applies principles and a framework to create efficiencies in the overall commissioning program.

This Guideline applies to commissioning of Proponents’ schedule 5.2 plant, specifically new or replaced equipment (including control and protection systems) in:

- Inverter-based or synchronous generating systems (GS) and integrated resource systems (IRS)<sup>1</sup> with a nameplate rating of 5 megawatts (MW) or more, and
- Synchronous condensers (SC), either as part of a GS or IRS of 5 MW or more, or as a standalone system of 5 MVA or more.

This Guideline deals with aspects of commissioning that are critical to the operation of the plant in the power system<sup>2</sup>. Key objectives of plant commissioning include the following:

1. Demonstrate compatibility with operation in the power system (that is, the plant does not have an adverse impact on power system security or quality of supply).
2. Demonstrate compliance with performance standards<sup>3</sup>.
3. Obtain data for validation of plant models (that is, data required for R2 model validation).

This Guideline does not impose mandatory requirements on Proponents in addition to those in the NER. For GS, IRS and SC proponents that are not subject to NER 5.8 commissioning requirements, AEMO has no formal role in the commissioning process. In those cases, Network Service Providers (NSPs) may choose to use this framework as a guide for those proponents, with adjustments as appropriate for the commissioning plant.

## 1.2. Abbreviations and definitions

Terms defined in the National Electricity Law and the NER have the same meanings in this Guideline, unless otherwise specified. For ease of reading, NER-defined terms are not italicised.

The table below identifies the meanings of other abbreviations and terms used in this document.

---

<sup>1</sup> The Guideline does not cover load components within an IRS (other than bi-directional units). Proponents should consult with the NSP regarding commissioning requirements for these load components.

<sup>2</sup> The NSP may require test certificates to confirm compliance with relevant Australian Standards, as described in NER 5.8.1(b). Additional tests beyond those considered in this Guideline may be agreed between the NSP and the Proponent.

<sup>3</sup> Performance standards form a part of the connection agreement. NER 5.2.5(a) and NER 5.2.5A(a) require Generators and IRP to comply with their performance standards.

Term	Definition
AGC	Automatic generation control system in accordance with NER S5.2.5.14
AVR	Automatic voltage regulator
CP	Checkpoint
Commissioning program	A plan for commissioning described under NER 5.8.4(a) (also known as commissioning test plan)
COMTRADE	Common format for Transient Data Exchange for power systems
CSF	Critical success factors
CSV	Comma-separated values
EMT	Electromagnetic transient
FCAS	Frequency control ancillary services
GS	Generating system
HP	Hold point
Hz	Hertz
kHz	Kilohertz
IRS	Integrated resource system
IRP	Integrated Resource Provider
MMS	AEMO's Market Management System
ms	Millisecond(s)
MV	Medium voltage
MVA	Megavolt ampere(s)
MVA <sub>r</sub>	Megavolt ampere(s) reactive
MW	Megawatt(s)
NEM	National Electricity Market
NER	National Electricity Rules
NSP	The relevant Network Service Provider
OEL	Over excitation limiter
OEM	Original equipment manufacturer
PFR	Primary frequency response in accordance with NER 4.4.2(c1)
PPA	Power Purchase Agreement
PPC	Power plant controller
Proponent	The registered Generator, Integrated Service Provider or Customer in relation to a GS, IRS or SC, responsible for conducting commissioning of that plant in coordination with the NSP
PSCAD™/EMTDC™	Power Systems Computer Aided Design/Electromagnetic Transient with Direct Current
PSDS	Power system data sheets, refers to the Power System Design Data Sheet and the Power System Setting Data Sheet, referred to in NER S5.5.7
PSMG	Power System Model Guidelines
PSS®E	Power System Simulator for Engineering
pu	Per unit
R2	Refers to the status of a plant after completion of commissioning
RMS	Root mean square
RUG	Releasable User Guide
s	Second(s)

Term	Definition
SC	Synchronous condenser
SCADA	Supervisory control and data acquisition
SCL	Stator current limiter
STATCOM	Static compensator
SVC	Static VAR compensator
SIPS	System Integrity Protection Scheme
SSA	System Strength Agreement
S5.2.X.X	The performance standards applicable to the generating system, integrated resource system or synchronous condenser being commissioned – “S5.2.X.X” refers to the clause in Schedule 5.2 of the NER from which the applicable performance standard is drawn
UEL	Under excitation limiter
UPS	Uninterruptible power supply
V	Volt(s)
VDS	VAR dispatch scheduling system
VRE	Variable renewable energy
WTG	Wind turbine generator

### 1.3. Related documents

Documents related to this Guideline are provided below.

Title	Location
AER Rebidding and Technical Parameters Guideline	<a href="https://www.aer.gov.au/industry/registers/resources/guidelines/rebidding-and-technical-parameters-guidelines">https://www.aer.gov.au/industry/registers/resources/guidelines/rebidding-and-technical-parameters-guidelines</a>
Communications System Failure Guidelines	<a href="https://www.aemo.com.au/energy-systems/electricity/national-electricity-market-nem/participate-in-the-market/network-connections/transmission-and-distribution-in-the-nem/completion">https://www.aemo.com.au/energy-systems/electricity/national-electricity-market-nem/participate-in-the-market/network-connections/transmission-and-distribution-in-the-nem/completion</a>
Congestion information resource	<a href="https://aemo.com.au/energy-systems/electricity/national-electricity-market-nem/system-operations/congestion-information-resource">https://aemo.com.au/energy-systems/electricity/national-electricity-market-nem/system-operations/congestion-information-resource</a>
Guide to Registration Exemptions and Production Unit Classifications	<a href="https://aemo.com.au/consultations/current-and-closed-consultations/guide-to-generator-exemption-and-classification-of-generating-units-consultation">https://aemo.com.au/consultations/current-and-closed-consultations/guide-to-generator-exemption-and-classification-of-generating-units-consultation</a>
Limits advice	<a href="https://aemo.com.au/en/energy-systems/electricity/national-electricity-market-nem/system-operations/congestion-information-resource/limits-advice">https://aemo.com.au/en/energy-systems/electricity/national-electricity-market-nem/system-operations/congestion-information-resource/limits-advice</a>
Network Outage Schedule	<a href="https://aemo.com.au/energy-systems/electricity/national-electricity-market-nem/data-nem/network-data/network-outage-schedule">https://aemo.com.au/energy-systems/electricity/national-electricity-market-nem/data-nem/network-data/network-outage-schedule</a>
Power System Model Guidelines (PSMG)	<a href="https://aemo.com.au/energy-systems/electricity/national-electricity-market-nem/participate-in-the-market/network-connections/modelling-requirements">https://aemo.com.au/energy-systems/electricity/national-electricity-market-nem/participate-in-the-market/network-connections/modelling-requirements</a>
Commissioning Toolkit	<a href="https://www.aemo.com.au/energy-systems/electricity/national-electricity-market-nem/participate-in-the-market/network-connections/transmission-and-distribution-in-the-nem/completion">https://www.aemo.com.au/energy-systems/electricity/national-electricity-market-nem/participate-in-the-market/network-connections/transmission-and-distribution-in-the-nem/completion</a>

### 1.4. How to use this document

This Guideline is a resource for commissioning new or replacement schedule 5.2 plant connecting to the NEM.

- Section 1 describes the purpose of this Guideline and how to use it.

- Section 2 describes the high-level commissioning process and the key principles of the commissioning framework.
- Section 3 describes how to categorise tests under the commissioning framework.
- Section 4 describes the contents of a commissioning program and provides guidance and practical examples on how to develop the test structure consistent with the principles described in Sections 2 and 3.
- Section 5 describes the requirements and processes during commissioning.
- The appendices provide examples of default test categorisation, risk assessment and measurement point layout.

The Commissioning Toolkit contains sample templates and test descriptions to assist Proponents to develop their commissioning programs in accordance with this Guideline.

## 2. Commissioning framework

### 2.1. Commissioning process

The commissioning process has six key steps:

- Agree commissioning program scope.
- Prepare and submit commissioning program.
- Commission plant.
- Lead up and release to full operation.
- R2 model validation.
- Ongoing compliance monitoring.

These steps are detailed below with more information on each step included in the subsequent chapters. Figure 1 below shows how these steps form the commissioning process.

Figure 1 High level commissioning process

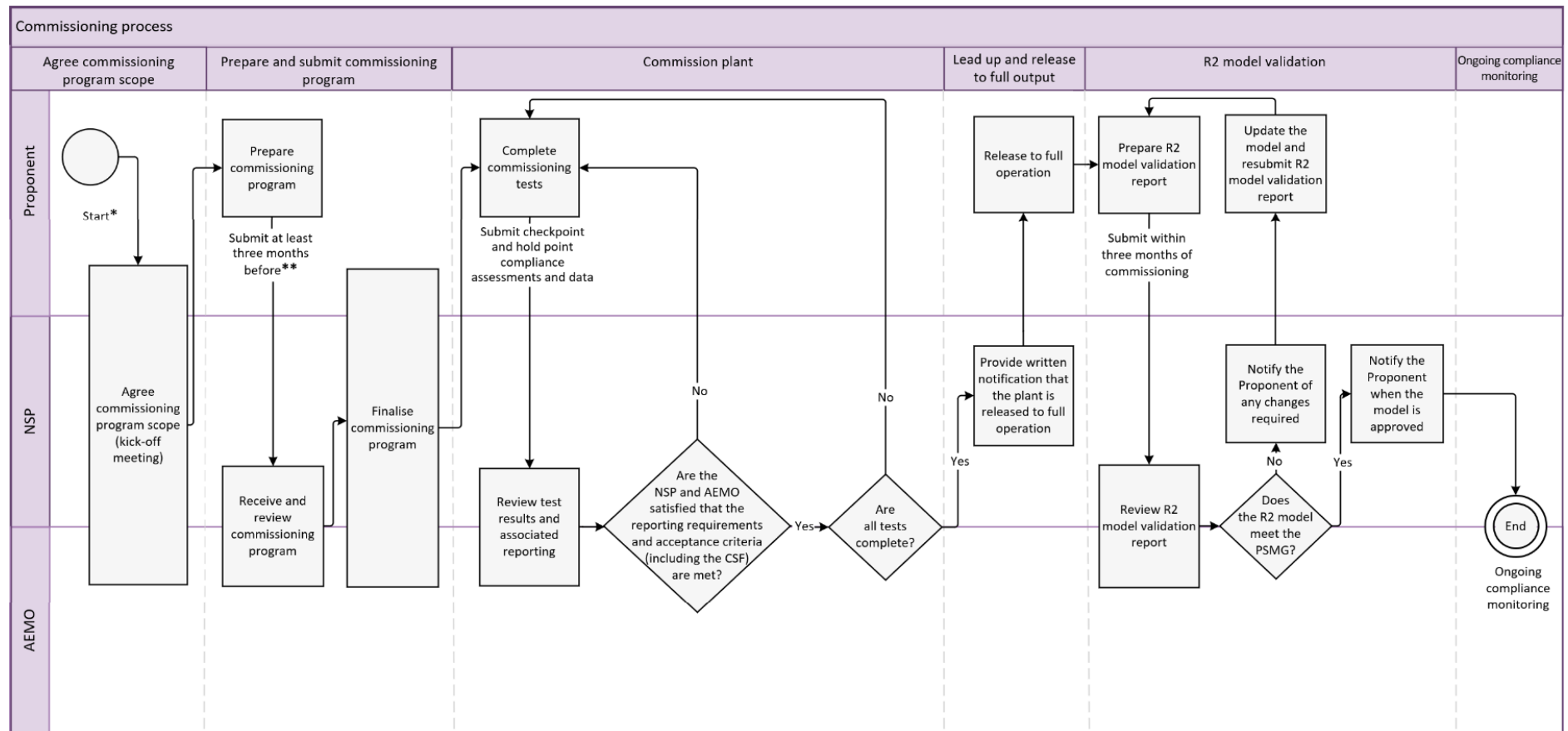

NSP: Network Service Provider. CSF: critical success factors. PSMG: Power System Model Guidelines. R2: Refers to the status of a plant after completion of commissioning.

\* The Proponent is encouraged to commence early engagement during the R1 process to discuss the draft commissioning program with the NSP and AEMO.

\*\* A three-month period is mandated for transmission connections. For distribution connections, NER 5.8.4 requires submission at least one month before commissioning, but AEMO recommends that distribution projects also submit at least three months before the proposed commissioning date.

### 2.1.1. Step 1: Agree commissioning program scope

Before preparing a commissioning program, the Proponent has a kick-off meeting with the NSP and AEMO to discuss:

- The construction program and anticipated timing for project milestones, including any physical limitations.
- The structure and content of the commissioning program.
- Any anticipated interactions between network limits (for example, from planned outages) and the commissioning program.
- Tests and acceptance criteria.
- Use of model overlays, including which software to use and data required.
- Expectations for measurement of plant quantities and reporting.
- Expected timeframes for submission of report/information by the Proponent and for the review by the NSP and AEMO.
- Use of pre-test simulations.
- The test results and other data required for model validation post-commissioning.
- The Proponent's contractual dependencies.
- Frequency control ancillary service (FCAS) tests, if the Proponent intends to participate in FCAS markets, automatic generation control (AGC) tests, and VAR dispatch scheduling system (VDS) tests.
- Any special arrangements around system integrity protection schemes (SIPS), if relevant.
- The communications protocol, ways of working together, and managing changes.
- Any special NSP requirements around advanced notice of testing or documentation.

This discussion will be informed by design information and modelling provided by the Proponent to the NSP and AEMO not less than three months before the proposed commencement of commissioning<sup>4</sup>.

Agreeing the commissioning program scope with the NSP and AEMO early in the commissioning process will accelerate both preparation and approval of the commissioning program.

### 2.1.2. Step 2: Prepare and submit commissioning program

Proponents must submit a commissioning program to the NSP and AEMO at least three months before commissioning transmission-connected plant, or one month before commissioning a distribution-connected plant<sup>5</sup>. In either case AEMO recommends early engagement to facilitate efficient and timely development, review and approval of the commissioning program.

Within 15 business days of receipt of the commissioning program, the NSP, in consultation with AEMO, will notify the Proponent that they either agree with the proposed program, or require changes and will

---

<sup>4</sup> NER 5.8.3.

<sup>5</sup> NER 5.8.4(b).

work with the Proponent to finalise the document. The Proponent, the NSP and AEMO will then work together to minimise revisions of the commissioning program before approval.

### 2.1.3. Step 3: Commission plant

The Proponent undertakes commissioning of plant in accordance with the agreed commissioning program (see Section 4.1). The Proponent may propose changes during commissioning for consideration by the NSP and AEMO (see Section 5.8).

### 2.1.4. Step 4: Lead up and release to full operation

Prior to full operation, the NSP will assess the following matters in consultation with AEMO:

- All testing according to the agreed commissioning program is complete.
- All reporting requirements have been met to an acceptable standard.
- Compliance with performance standards has been adequately demonstrated, with an appropriate management plan established for any outstanding non-compliances<sup>6</sup>.
- Measurement data is of sufficient quality and quantity and shows sufficient alignment with the plant model that a fit-for-purpose validated plant dynamic model can be developed.
- The NSP and AEMO have received the most up-to-date plant model incorporating any modifications made during the commissioning process.

Once satisfied with the matters listed above, the NSP will notify the Proponent and AEMO in writing that the plant is released to full operation (subject to the NEM dispatch and constraints process<sup>7</sup>).

If AEMO considers that a non-compliance or model inaccuracy will adversely impact power system security or the assessment of power system security, AEMO may apply network constraints to the plant's operation to mitigate the potential impact until the matter is remedied<sup>8</sup> (see Section 5.9).

### 2.1.5. Step 5: R2 model validation

Within three months of completion of commissioning, Proponents must submit to the NSP and AEMO the plant's dynamic model(s) validated against measurement<sup>9</sup> (also known as R2 model validation), along with an R2 model validation report as per NER S5.2.4(d)(1) and the Power System Model Guidelines (PSMG)<sup>10</sup>.

---

<sup>6</sup> NER 5.8.5(d).

<sup>7</sup> See <https://aemo.com.au/energy-systems/electricity/national-electricity-market-nem/system-operations/power-system-operation/power-system-operating-procedures>.

<sup>8</sup> NER 5.7.3(f).

<sup>9</sup> To validate and update the information required under NER S5.2.4(b).

<sup>10</sup> At <https://aemo.com.au/energy-systems/electricity/national-electricity-market-nem/participate-in-the-market/network-connections/modelling-requirements>.

The validated model must be fit-for-purpose and contain sufficient detail for the NSP and AEMO to perform power system simulation studies in accordance with the requirements and circumstances specified in the PSMG<sup>11</sup>.

As power system security assessments rely on the quality of the plant models, it is important that model validation against measurement is completed promptly. The roles of the NSP and AEMO in model review and approval are:

- The NSP and AEMO will review the model validation.
- The NSP will notify the Proponent of any changes required because of the NSP and AEMO's combined review.
- The NSP will notify the Proponent when the validated model is approved after consultation with AEMO.

The following recommended timelines apply for finalisation of the model validation process:

- Initial review of the submitted R2 model by the NSP and AEMO completed within 20 business days of receiving the validated model and associated R2 model validation report, with feedback to include any changes required to achieve an acceptable validated model.
- Finalisation of the R2 model by the Proponent, incorporating requested changes as reasonably practicable, within three months of feedback from the NSP and AEMO on the initial submission.

The R2 model validation report should incorporate model validation for relevant system events<sup>12</sup> during and following the commissioning period, up to the submission of the R2 model validation report.

The NSP and AEMO have a need to complete R2 model validation as quickly as practically possible, to assure themselves that a representative model of the plant (as installed) is being used for power system operations. Power system events are random in nature. This makes it impractical to wait for a suitable fault to occur near the plant before completing the R2 model validation report. However, at any time after a power system event occurs, the NSP or AEMO may request analysis of the plant's behaviour and response to the power system event to confirm that the plant's actual response to the event is consistent with its performance standards and model characteristics. This information and assessment could also be used to support the plant's compliance program.

If modelling issues remain unresolved, there is potential for ongoing non-compliance with NER obligations<sup>13</sup>. If AEMO holds the reasonable opinion that inadequate model representation impedes or will impede AEMO's ability to carry out its power system security role, it may constrain the plant's operation until the Proponent has submitted evidence that the plant is performing substantially in accordance with the applicable model<sup>14</sup>.

---

<sup>11</sup> NER S5.2.4(b1).

<sup>12</sup> For fault ride through, model validation is achieved by monitoring the plant's response to actual power system events, as it is undesirable to induce the necessary power system conditions for a test.

<sup>13</sup> For example, performance standards (NER 4.15) and plant performance not being adequately represented by the model provided (NER S5.2.4).

<sup>14</sup> NER 5.7.3(f).

### 2.1.6. Step 6: Ongoing compliance monitoring

As soon as reasonably practicable, but no later than 6 months after commencing operation, or 6 months after AEMO gives notice of registration of the performance standards under NER 4.14(n), the Proponent must institute and maintain a compliance program<sup>15</sup>. The program must be consistent with the template for compliance programs maintained by the Reliability Panel<sup>16</sup>. Through the compliance program, the Proponent monitors performance standard compliance over the life of the plant.

## 2.2. Key principles

The following principles guide the design of a commissioning program. They support the development of programs that are fit-for-purpose, efficient, and aligned with power system security and quality of supply obligations:

- Commissioning programs should be fit-for-purpose, with testing requirements commensurate with the potential impact of the plant on the power system and other Network Users.
  - Low impact plant should have less extensive test requirements, focusing on core performance criteria.
  - High impact plant should have more comprehensive test requirements and will typically have tests at more operating levels (see Section 2.2.1 below for how plant impact is assessed).
- Monitoring and reporting practices should align with the time-sensitivity of the matter being assessed (for example, stability-related outcomes require prompt and concise reporting, while less time critical<sup>17</sup> compliance outcomes allow for more flexible reporting timelines).
- The commissioning program must ensure that sufficient data is obtained to validate the plant's dynamic model (that is, R2 model validation), with the extent of model validation reflecting the plant's impact:
  - More thorough model validation is required for high impact plant (for example, large plant, or at a sensitive location).
  - Less model validation is required for low impact plant.
- The approach enables efficient progress toward full operating capacity, without adverse impact on power system security or the quality of supply to other Network Users. Efficiency measures include:
  - For variable renewable energy (VRE) plants, commissioning programs should allow flexibility in test timing and test levels to make effective use of energy source availability, as appropriate.
  - Unnecessary duplication of tests should be avoided (see Section 2.2.3 for further detail).
  - Secondary operating mode testing should be less extensive than primary mode testing if the plant will rarely operate in the secondary operating mode.

---

<sup>15</sup> In accordance with NER 4.15(b).

<sup>16</sup> See <https://www.aemc.gov.au/regulation/electricity-guidelines-and-standards#reliability>.

<sup>17</sup> Which also contributes to efficiency.

- Model overlay requirements should be based on engineering judgement to support efficient commissioning (see Section 3.3.3 for further detail).

### 2.2.1. Assessing plant impact

As outlined above, assessing the impact of plant is critical to developing a fit-for-purpose commissioning program. The level of impact will generally be related to plant's size relative to the strength of the power system around it:

- Plant (either alone or in combination with other electrically close plant) that does not materially impact power system security or quality of supply if it becomes unstable, or trips, is considered 'low impact plant'.
- Plant (either alone or in combination with other electrically close plant) that could adversely affect power system security and potentially many other Network Users is considered 'high impact plant'.

The impact can be evaluated quantitatively considering the voltage and frequency change assessed at the connection point:

- Voltage impact should the plant become unstable, considering its range of reactive power and active power – that is, the voltage change over the full range of active power or reactive power.
- Voltage impact should the plant trip, considering megavolt amperes (MVA) level (injecting or absorbing), and/or
- Frequency impact should the plant trip.

Suggested thresholds are:

- Voltage impact<sup>18</sup> threshold of 3% on transmission and sub-transmission, and 5% on distribution<sup>19</sup>, and
- Frequency impact threshold<sup>20</sup> of 0.15 hertz (Hz) deviation for the mainland<sup>21</sup>, and a wider band of 0.5 Hz deviation for Tasmania<sup>22</sup>.

It is noted that these thresholds are primarily used to inform hold point levels as described in Section 3. Plant may be considered high impact plant even if these thresholds are not exceeded. The NSP, in consultation with AEMO will consider local factors when deciding impact level, such as the potential for an active power swing to cause a transmission line or interconnector to trip or the potential for cascading tripping of other plant. For high impact plant, the risk of unintended operation outside of plant active power or reactive power limits may also need to be considered. For IRS with bi-directional

<sup>18</sup> This is conceptually a steady-state voltage change, based on system-normal conditions, not a time-based criterion – assess with load flow.

<sup>19</sup> The DNSP may, at their discretion, apply a 3% threshold to distribution connections, where the power quality of other Network Users could be affected by tripping or instability.

<sup>20</sup> These numbers are based on the normal operation frequency band in the Frequency Operating Standard, at <https://www.aemc.gov.au/market-reviews-advice/review-frequency-operating-standard-2022>. It is not suggested that power system simulations using the NEM model be used to assess frequency impacts for each GS or IRS; rather, the relevant NSP(s) and AEMO may define standard MW thresholds based on grid frequency impacts.

<sup>21</sup> In mainland NEM regions, this frequency threshold corresponds to approximately 225 MW with current inertia levels.

<sup>22</sup> In Tasmania, this frequency threshold corresponds to approximately 50 MW, under islanded conditions with current inertia levels.

units, the full range of active power absorbed and generated must be considered when assessing voltage and frequency impacts of power swings or instability.

Note that when a new connection is electrically close to other Network Users' plant, adverse quality of supply impacts could affect those Network Users. In these situations, the NSP is likely to place more emphasis on testing and monitoring matters related to quality of supply, even if the plant is low impact in the context of the broader NEM.

### 2.2.2. Maintaining plant stability – critical success factors

Critical to a plant's suitability for operation on the power system is its ability to maintain stable operation. The Guideline captures this principle by defining critical success factors (CSF) that are assessed throughout commissioning and must be met continuously. If at any time the CSF are not met, the plant must revert to the previous state at which the CSF were met and notify AEMO<sup>23</sup> and the NSP.

Satisfying the CSF means the following:

- The plant is stable, demonstrates adequate damping and does not exhibit unexpected protection operation causing tripping.
- The plant is stable<sup>24</sup> for voltage reference steps (or other primary mode reference, if applicable).
- Differences compared to simulation (where applicable) are small or explainable and do not indicate a potential adverse power system security impact.
- The plant has measurement systems in service, as agreed in the commissioning program. See Section 5.3 on measurement systems.
- Communications fail-safe mechanisms<sup>25</sup> (where applicable) are in service, and functioning correctly, for loss of communications between the Power Plant Controller (PPC) and key plant equipment, including generating units, measurement units and remote communication units, as agreed in the commissioning program.

### 2.2.3. Repeating tests at multiple stages or operating levels

Engineering judgement will be required to assess which tests need to be performed at multiple points in the commissioning program, including the following considerations:

- Does the test have the potential for different outcomes at different operating levels or units in service? For example, reactive power capability may change with active power output and production units in service<sup>26</sup>, communications failure test outcomes may differ with the number of units in service.

---

<sup>23</sup> NER 4.8.1.

<sup>24</sup> Visual confirmation of halving time can be made. Halving time of less than five seconds forms a part of the definition of adequately damped (for oscillations between 0.05 Hz and 0.6 Hz). For oscillations with frequency greater than 0.6 Hz, shorter halving time is expected (damping ratio 0.1). If the outcome is uncertain, assessment can be made against S5.2.5.13 requirements.

<sup>25</sup> See Communication System Failure Guidelines, at <https://www.aemo.com.au/energy-systems/electricity/national-electricity-market-nem/participate-in-the-market/network-connections/transmission-and-distribution-in-the-nem/completion>.

<sup>26</sup> Consideration of plant impact level might influence whether testing reactive power with reduced units in service is needed.

- How much impact does this plant have on the power system? A fit-for-purpose commissioning program for a high-impact plant will have more tests, particularly if there is potential for different outcomes at different operating levels.
- Complex systems with combinations of technology (for example, hybrid technologies or controllers from multiple OEMs in one connection or new technology) may require additional tests at multiple levels or different configurations.
- Statistical testing (such as harmonic emissions) should be based on normal plant configuration, across its normal operating range. Operation limited to low operating levels or reduced number of units in service is not suitable to assess compliance for statistically based tests. But the NSP may require monitoring in this instance to check that planning levels are not exceeded.
- Duplicated controllers (such as PPCs or automatic voltage regulators (AVR)) will need to be tested individually. Consideration should be given to alternating between controllers at progressive operating levels.

### 3. Test categorisation

Various tests are required to meet the commissioning requirements under the NER. The commissioning framework described in this Guideline categorises tests according to their primary purpose, as outlined in the following sections and shown in Figure 2.

The test categories are:

- Preliminary tests – testing required to confirm system functionality before energisation or at low operating levels (typically below 5 MW).
- Checkpoint tests – testing required to confirm stable operation of the plant.
- Hold point tests – testing required to confirm compliance with performance standards related to power system security.
- Flexible tests – tests required to demonstrate compliance with performance standards and/or to obtain data for model validation, but which are not related to power system security, can be undertaken at any operating level and at any time during the commissioning period.

Grouping the tests into these categories allows processes and reporting requirements to be tailored by category to achieve an efficient commissioning program which is fit-for-purpose. Appendix A provides details of the default tests conducted in each category.

Parties may agree to assign specific tests to different categories where warranted, considering the technology, the nature of the connection and the surrounding network, and the impact of the plant on the power system, having regard to the principles for design of the commissioning program. The structure of a commissioning program (that is, the number of checkpoints and hold points) will also depend on these considerations as discussed in Section 4.2.

Figure 2 Test categories

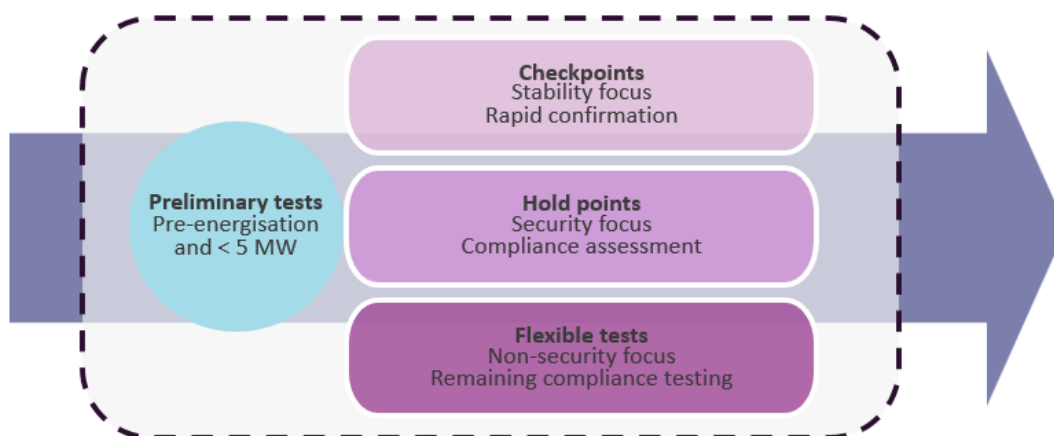

### 3.1. Preliminary tests

#### 3.1.1. Description and purpose

Preliminary tests<sup>27</sup> are undertaken before energisation without connection of the plant, or with plant operating at low level, typically less than 5 MW. They confirm key system functionality that is required for operation. For synchronous machines there are also specific tests that must be undertaken offline, to verify plant characteristics for model validation purposes.

#### 3.1.2. Preliminary test application and process

Preliminary tests will generally include testing of protection systems, communication and SCADA. For synchronous machines there are some additional preliminary standard tests that are performed before synchronisation. Appendix A Table 1 lists typical preliminary tests.

The NSP may require evidence of factory testing or certification or on-site tests to prove that the plant meets the requirements of applicable Australian standards, the NER and the connection agreement before energisation.

Commissioning of relevant protection, SCADA, remote monitoring, communications systems and market systems (if applicable) is required before progressing to the remaining commissioning program tests, unless otherwise agreed with the NSP and AEMO.

#### 3.1.3. Preliminary test reporting

The NSP will advise a Proponent of its acceptance criteria and reporting requirements for preliminary tests.

<sup>27</sup> Preliminary tests have in the past been referred to as HP0, but the process and reporting arrangements for preliminary tests differ from those of hold points described below, so this Guideline uses the term 'preliminary test' instead.

## 3.2. Checkpoints

### 3.2.1. Description and purpose

Checkpoints are specified test levels and number of units, primarily used to confirm the stability of the plant's operation<sup>28</sup>. Checkpoints ensure plant that is not stable (or is poorly damped) is quickly restored to operation at a level and number of units at which it is stable and well damped. This test category is designed to facilitate rapid confirmation, allowing plant to progress to a higher level if the CSF are met.

### 3.2.2. Checkpoint application and process

Checkpoint tests relate to stable operation of the plant for:

- Reactive power controller operation for primary operating mode, typically voltage control or power factor control as per performance standard S5.2.5.13<sup>29</sup>, and
- Active power controller operation (where applicable).

Appendix A Table 2 lists tests characterised by default as checkpoint tests.

Typical applications for checkpoints include:

- Following addition of units in service in staged commissioning, above a threshold for security impact (described in Section 2.2.1).
- Where new technology or unusual combinations of technology are employed, to provide confidence about performance of this technology at lower operating levels, or different configurations of the plant (in lieu of additional hold point(s)), and
- Where, in a previous hold point or checkpoint, the plant exhibited unstable or poorly damped behaviour; even though it was resolved at a lower operating level, a more cautious approach to increased operating level is warranted.

Checkpoints are not necessary for low impact plant, where the potential to impact power system security is low.

The NSP, in consultation with AEMO, may agree to:

- Remove a hold point (see Section 3.3) and replace it with a checkpoint, subject to successful completion of previous hold points or checkpoints, and/or
- Remove a checkpoint, subject to satisfactory outcomes from a previous hold point or checkpoint.

Any conditional arrangements should be documented in the commissioning program, with the agreed acceptance criteria.

Satisfying the CSF is a condition for NSP and AEMO acceptance of the checkpoint and AEMO lifting the constraint (cap) on operation to the next agreed level in the commissioning program. If the plant cannot

---

<sup>28</sup> In checkpoints and the CSF more generally, stability is assessed by visual inspection of results, rather than calculation. Any oscillation with a halving time of five seconds or more would be of concern, but repeated small signal oscillations of shorter duration, in the absence of a power system disturbance, might also indicate inadequate damping of an oscillation mode.

<sup>29</sup> A reactive power reference step test may be required before a voltage reference step test as an initial stability check, for a high impact IBR plant.

meet the CSF, it must be returned to the previous level where it has met the requirements. Once the CSF have been met and approval has been obtained, flexible tests up to the approved level can be undertaken, noting that the CSF stability condition always applies.

### 3.2.3. Checkpoint reporting requirements

The following reporting requirements apply for checkpoints:

- Screenshots of tests results (all checkpoint tests).
- Comparison of primary mode (for example, voltage) reference step test measurements with pre-test simulations (where required in the commissioning program). This can be provided as a side-by-side comparison on the same scale, unless the NSP or AEMO require them to be overlaid.
- Confirmation that communications fail safe mechanisms and monitoring are in service.

All information must be provided to the NSP and AEMO within 24 hours of the tests, preferably on the same day. Target turnaround time from the NSP and AEMO, if possible, is same day.

Checkpoint test data can be used at a later date for compliance assessment and/or model validation purposes and may be required to investigate unexpected results. It is recommended that the Proponent downloads the highest-resolution SCADA data on the day, as it may otherwise be overwritten. High-speed data for tests should also be downloaded or made available to the NSP on request, with agreed arrangements documented in the commissioning program.

## 3.3. Hold points

### 3.3.1. Description and purpose

Hold points are specified output levels and number of units online, at which the plant will be capped<sup>30</sup> until both testing and reporting requirements, including for performance standard compliance, are signed off by the NSP and AEMO. Any non-compliances must be resolved or managed to the satisfaction of the NSP and AEMO before the plant can progress beyond the hold point. Hold points are primarily for the purpose of assessing performance elements related to power system security.

### 3.3.2. Hold point application and process

Appendix A Table 3 lists tests which are typically categorised as hold point tests. As a minimum, hold points are required during the commissioning process to validate:

- Controller setting confirmation, and
- Power system security confirmation.

Each commissioning program will have at least one hold point, at the final operating level.

Since stability is an important element of power system security, stability related tests which are required for checkpoints will also be required for hold points. Tests specifically related to stability for common operating conditions (such as primary mode reference tests) should be undertaken ahead of

---

<sup>30</sup> Typically implemented as a network constraint in NEM dispatch.

flexible tests, to assess the CSF. If the CSF are satisfied, the plant can continue operating up to the hold point cap, while other hold point tests are undertaken and the hold point test report is being reviewed<sup>31</sup>. If at any point the CSF are not satisfied the plant operating level must be reduced to the previous level where CSF were satisfied (see Section 2.2.2).

### Controller setting confirmation

As part of the hold point testing, checking a small number of tests against simulations, is valuable to confirm correct implementation of controller settings.

For high impact plant, these checks should be undertaken as early as possible, at low plant operating levels<sup>32</sup>, to avoid potential retest or adverse power system security impact from incorrect performance. Where the NSP or AEMO assesses that poor alignment of model and measurement indicates incorrectly applied plant settings, this should be investigated and corrected promptly before further tests. Otherwise, where AEMO agrees the misalignment does not represent a material adverse power system security impact<sup>33</sup>, the NSP may agree that testing can continue in parallel with investigation of the discrepancy.

Low impact plants may only require a single hold point at full output, in which case controller settings would be confirmed in that hold point.

In either case, if it is found that the settings have been incorrectly applied, then previously completed tests may need to be repeated before finalising the tests at full output. The need to repeat tests will be assessed case-by-case.

### Power system security confirmation

Other than for confirmation of settings, hold points are also required if there is a potential power system security impact or potential impact to other Network Users. The number of additional hold points can be determined by considering the power system impact (including adverse impact on other Network Users) of power swings, instability or tripping. See Section 2.2.1 on impact thresholds and other considerations and Section 4.2 for examples on establishing hold point levels.

### 3.3.3. Hold point reporting requirements

Hold point reporting includes:

- Brief reporting, following stability-related tests, of the type described for checkpoint reporting in Section 3.2.3, and
- A hold point report, provided at the completion of the hold point, focused on performance standard compliance.

Hold point reports should include:

---

<sup>31</sup> If hold point completion is delayed, the processes described in Section 5.8.1 apply.

<sup>32</sup> In some cases, early testing may be conducted with reduced units in service. An aggregate model made for full units in service will likely be less accurate with reduced units, which may make confirmation of settings less certain. Re-aggregation of the model with actual in-service plant would rectify this issue, if the effort to re-aggregate is warranted.

<sup>33</sup> For example, a small magnitude error, or a response that is less oscillatory than the model predicted, or similar damping but at a marginally different frequency.

- A compliance summary, and for each test, as agreed in the commissioning program (see the Commissioning Toolkit's Commissioning program template<sup>34</sup>):
  - A summary of relevant test conditions.
  - Plots of test measurements, at agreed measurement points.
  - Model and measurement overlays, and
  - An evaluation against acceptance criteria for each test, including compliance with relevant performance standards.
- Other information, such as SCADA downloads and test result downloads, if required by the NSP and AEMO (compliance assessment should focus on connection point measurements, but other measurements, including SCADA, may be required to support analysis<sup>35</sup>).

The time to prepare and review hold point reports depends on the number of tests and the extent of required model overlays. An indicative timeframe is one week to prepare and one week to review, but this timeframe may be extended if non-compliances or performance issues are identified in the report.

The final hold point report may be combined with the final commissioning report (see Section 5.7.1).

### Model overlays

Overlays of measurements with simulation results (that is, model overlays) can be used to provide confidence that:

- The implemented settings reflect the settings proposed from the model, for tests with dynamic responses.
- The R1 model reflects the plant's performance.
- A fit-for-purpose dynamic model validated against measurement can be produced following completion of commissioning.

In accordance with the principles described in Section 2.2, model overlay requirements should be based on engineering judgement to support efficient commissioning. For example, where 1%, 2.5% and 5% voltage step tests are undertaken, overlays for the 1% and 2.5% steps would not be considered necessary if there is no unusual or unexpected performance, and there is good alignment in voltage and reactive power for the 5% step. Minimising overlays at intermediate hold points will assist to streamline the commissioning process.

Overlays are most valuable for tests that have fast, dynamic responses. They are not useful for steady state tests, as root mean square (RMS) dynamic models are primarily used for assessing transient stability phenomena. Requirements for overlays should focus on larger magnitude responses which are less susceptible to measurement quantisation error and noise.

Typically, an RMS dynamic model will be sufficient for hold point overlays and has advantages in terms of simulation speed. However, if there is doubt about the correctness of the model or its settings, the

---

<sup>34</sup> At <https://www.aemo.com.au/energy-systems/electricity/national-electricity-market-nem/participate-in-the-market/network-connections/transmission-and-distribution-in-the-nem/completion>.

<sup>35</sup> For example, illustrating energy source variability impacts on results.

NSP or AEMO may request additional modelling using an electromagnetic transient (EMT) model which more closely resembles the plant's firmware.

### Accuracy requirements for hold point model overlays

A model accuracy level within  $\pm 10\%$  of the change in a measured quantity is generally adequate for model overlays during hold points. Accuracy assessment for hold points should focus on the connection point quantities and/or terminal quantities as agreed by the NSP or AEMO (for example, for a synchronous machine).

For small changes in measured and modelled quantities that result in very small accuracy bands, similar in size to the background measurement noise or measurement error, alignment deviations beyond the accuracy bands may be ignored for commissioning purposes. Consideration should also be given to increased measurement errors at low operating levels when comparing the plant performance with models.

Accuracy of the model at unit terminals should not be a hold point acceptance criterion for multi-unit plants that use an aggregate model<sup>36</sup>.

For low impact plant, the NSP and AEMO may agree that comparison of test results with pre-test simulations (explained in Section 5.2) could be an acceptable alternative to model overlays, noting that the alignment between pre-test simulation and test results may be reduced.

If the NSP and AEMO reasonably consider that the model's inaccuracy may prevent reliable prediction of the plant's impact on power system security, the matter must be resolved before proceeding beyond the current hold point<sup>37, 38</sup>. Otherwise, the NSP and AEMO may agree, on a case-by-case basis, that inability to demonstrate model accuracy requirements should not prevent the plant from proceeding to the next operating level.

Minor simulation and measurement alignment differences in model overlays<sup>39</sup> and minor exceedance of accuracy tolerance should not prevent progress to the next operating level. The NSP and AEMO may, at their discretion, require model inaccuracy to be investigated and resolved before release to full operation.

## 3.4. Flexible tests

### 3.4.1. Description and purpose

Tests that are not power system security-related, do not need to be performed at a specific operating level and are not time critical, are categorised as 'flexible tests' (that is, they are not required as part of checkpoint or hold point testing). See Appendix A Table 4 for examples of flexible tests.

---

<sup>36</sup> Aggregate models simulate an 'average' unit-level response, but usually the nearest and furthest units in a distributed GS are monitored. Unit-level model accuracy cannot be relied on, especially for plant with large collector systems and significant impedance between units. Instantaneous differences in ambient conditions between units also affect unit-level model-measurement alignment.

<sup>37</sup> Consistent with NER 5.8.5(e) and NER 5.7.3(f).

<sup>38</sup> CSF also apply.

<sup>39</sup> For example, minor differences in initial condition alignment in time or magnitude.

Flexible arrangements can be made for when these tests are undertaken, which can contribute to a more efficient commissioning process. Flexible testing arrangements reduce the overall commissioning duration by enabling the following:

- Completion of flexible tests at or below the same operating level and number of units in service, during periods of hold point report preparation and review, provided the CSF have been satisfied.
- For VRE plant, periods of low energy source availability can be utilised more effectively. For example, if the wind level was insufficient for a wind farm to progress to a higher checkpoint or hold point level after successful completion of the previous checkpoint or hold point, flexible tests at or below the same output level and number of units in service could be completed, while waiting for wind conditions to improve.

### 3.4.2. Application and process for flexible tests

These flexible tests may be conducted at any time and in any order, at, or below, the operating level and number of units in service for which the CSF have been satisfied through checkpoint or hold point testing, unless restricted by the NSP or AEMO. The flexible tests may be conducted in conjunction with hold point tests, where convenient. Testing requirements may also specify the test to be conducted:

- At a particular operating level.
- Within a range of operating levels.
- With a minimum, maximum or particular number of units in service, or
- With conditions on the order of tests.

Commissioning programs should avoid unnecessary restrictions on flexible testing arrangements.

Note that the CSF equally apply for these tests. If instability or poor damping is detected, the process described in Section 5.9 for managing instability or poor damping must be followed.

### 3.4.3. Reporting requirements for flexible tests

Reporting for compliance assessment of the flexible tests is similar to that required for hold point reports. Model-measurement overlays are not required.

Unless otherwise required by the NSP or AEMO, reporting is required to be submitted as part of the final commissioning report.

## 4. Developing a commissioning program

### 4.1. Contents of a commissioning program

The commissioning program should include the following:

- Key plant details.
- Overview of tests including:
  - The structure of the commissioning program.

- A summary of the tests in each category and operating level (or range).
- Which tests require pre-test simulations, model overlays and/or for which measurements are required for R2 model validation.
- CSFs for checkpoints (if there are checkpoints).
- Agreed reporting requirements for checkpoints, hold points and flexible tests as well as the final commissioning report, including:
  - Model overlay requirements (in hold points) including associated software and accuracy requirements.
  - Pre-test simulations requirements and modelling software, and
- Explanation of the format used for test data file names (refer to the Commissioning Toolkit's Commissioning program template for an example).
- Descriptions of tests in each testing phase, including:
  - Test identifier, name and purpose.
  - Test pre-conditions, including flexibility around production units in service and test levels.
  - Risk assessment and risk controls (in accordance with the risk matrix) (see Appendix B for an example).
  - Test instructions.
  - Signals to be measured and plotted.
  - Measurement data file identifier.
  - Test acceptance criteria.
- Measuring equipment details, including a measurement point layout diagram (see Appendix C).
- Quantities to be recorded by measuring equipment.
- Reactive power capability curve.
- Risk matrix (see Appendix B for an example).
- Proponent's contractual dependencies (for example, SIPS contracts, System Strength Agreement (SSA) or Power Purchase Agreement (PPA)).

A Commissioning program template is available in the Commissioning Toolkit. The Commissioning program template applies to all technologies.

A Commissioning test library is available in the Commissioning Toolkit<sup>40</sup>, containing sample tests which may be used to populate the commissioning program once the program structure has been agreed. The test descriptions may need to be adapted to accommodate the specific design of the plant or the connection.

---

<sup>40</sup> At <https://www.aemo.com.au/energy-systems/electricity/national-electricity-market-nem/participate-in-the-market/network-connections/transmission-and-distribution-in-the-nem/completion>.

## 4.2. Commissioning test structure

The commissioning test structure (that is, the number and sequence of checkpoints [CP] and hold points [HP]) will depend on factors such as the plant's assessed impact and number of units available. This section provides examples of test structures for high and low impact plant, and for a staged commissioning program (for example, where a reduced number of units are in service due to construction delays).

### 4.2.1. High impact plant example

The following example is for a high impact plant, which requires hold points and checkpoints to confirm stability and security impact of the plant.

#### **Example test structure – for a high impact 450 MW plant**

For a 450 MW solar farm employing new technology, the NSP assessed that a 3% voltage change would occur at the connection point if the plant, operating at 200 MW and maximum reactive power supply, trips. This indicates a high-impact threshold of 200 MW. The example hold point and checkpoint levels are:

- Preliminary tests – up to 5 MW.
- 50 MW – HP1 setting confirmation and model alignment check (small subset of tests).
- 100 MW – CP1 (added for new technology).
- 200 MW – HP2 level at which threshold is exceeded.
- 400 MW – CP2 added since above the impact threshold level and new technology.
- 450 MW – HP3 final hold point.
- Flexible tests can be undertaken at outputs below the relevant HP or CP, where CSF have been satisfied.

This example includes:

- Three hold points: HP1 at low output level to confirm plant settings, HP2 at 200 MW where the plant is assessed to exceed the 3% voltage impact threshold described in Section 2.2.1, and HP3 at full output.
- HP1 and CP1 are conducted below the high impact threshold, reflecting a cautious approach for new technology. If the technology were well established, HP1 and CP1 could be combined at 100 MW into a single hold point, for setting verification.

### 4.2.2. Low impact plant example

The following example is for a plant that is low impact<sup>41</sup>, so hold points and checkpoints at lower operating levels are not required.

---

<sup>41</sup> It does not exceed the impact thresholds described in the previous section.

#### Example test structure – for a low impact 50 MW plant

A 50 MW plant connected at the same location as the example in Section 4.2.1 does not exceed the thresholds for requiring a hold point at a lower output. A single hold point capping export at full output level is appropriate in this case:

- Preliminary tests – up to 5 MW.
- 50 MW – HP1 for setting confirmation and as the final hold point.
- Flexible tests may be undertaken at any output. CSF must be satisfied.

The final commissioning report incorporates the HP1 report and results and compliance assessment from the flexible tests. There is no need for a separate hold point report for HP1.

In this example, some of the tests have requirements for lower output. All tests, other than the preliminary tests, are conducted with all units in service. Since the output cap is full output, the order of tests can be adjusted to accommodate the solar irradiance conditions during the commissioning period.

The Proponent may choose to check the overlay of their plant's response against the R1 model early in the testing. If they encounter poor alignment, it would be in the Proponent's interest to discuss this with the NSP and AEMO before submission of their final commissioning report.

#### 4.2.3. Staged commissioning example – reduced number of units in service

For projects involving staged construction, such as wind farms, a commissioning program can be developed to align and accommodate the Proponent's construction schedule. This approach will ensure that the commissioning process is efficient and coordinated with on-site activities facilitating the earliest possible release of plant capacity.

Checkpoints or hold points with fewer units in service may also be appropriate if the maximum voltage change exceeds the hold point voltage impact threshold. Performance standard compliance tests for which outcomes are insensitive to the number of units are well suited to hold points with reduced units, allowing compliance to be assessed with less potential impact on the power system<sup>42</sup>.

Since a subset of hold point and checkpoint test measurements is also used for R2 model validation, consideration should be given as to whether the quality of measurements from tests undertaken with reduced units in service is sufficient to validate a fit-for-purpose R2 model.

The following example incorporates staged commissioning into the test structure. While the staged process adds complexity, it can assist the Proponent to maximise yield from the plant while construction is in progress.

#### Example test structure – for a high impact 450 MW plant with staged commissioning

For a 450 MW wind farm, using 5 MW units, the construction program suits the commissioning of the plant in 100 MW increments plus one final 50 MW increment. The NSP assessed that a 3% voltage change would occur at the connection point if the plant, operating at 200 MW with 40

<sup>42</sup> For example, testing an emergency trip scheme required for a performance standard under S5.2.5.12.

units in service and maximum reactive power supply, trips. This means a threshold of 200 MW is required. The example hold point and checkpoint levels are:

- Preliminary tests – up to 5 MW (single turbine).
- 100 MW, from 20 units (construction stage 1) – HP1 setting confirmation and model alignment check and maximises yield before Stage 2 completion.
- 200 MW from 40 units (construction stage 2) – HP2 level at which voltage impact threshold is exceeded.
- 300 MW from 60 units (construction stage 3) – CP1 addition of units, above threshold level.
- 400 MW from 80 units (construction stage 4) – HP3 is two times the voltage impact threshold level and also maximises yield potential for this construction stage.
- 450 MW from 90 units (construction stage 5) – HP4, final hold point.
- Flexible tests – may be undertaken at any output below the relevant HP or CP level, but additional tests with all units in service may be required for model validation.

In this example:

- HP1 checks stability, model alignment, and basic functions such as ability to follow dispatch instructions. It also enables the plant to utilise all available units up to their maximum output in Stage 1 of the construction program, before construction stage 2 is completed.
- HP2 is required because the voltage threshold is exceeded.
- CP1 enables an increase in output in line with the construction program, with stability confirmation required because the plant size exceeds the voltage threshold.
- HP 3 accommodates construction stage 4 of the construction program and is a multiple of the voltage threshold level.
- The final hold point, HP4, is the first time this high-impact plant has all units in service, so this hold point would incorporate some tests at lower levels to confirm operation in the final plant configuration for various aspects of the performance standards and to obtain some additional measurement data for the R2 model validation.

Flexible tests are required in addition to those within the checkpoints and hold points. These tests would be agreed and documented in the commissioning program. This would include tests to be undertaken with reduced units in service (and reduced output) and tests that require all units to be in service. This planning may assist to reduce the overall duration of commissioning depending on the actual weather conditions during commissioning.

### 4.3. Hybrid systems

Commissioning hybrid systems that employ more than one technology can add complexity to the commissioning program. Within the broader requirement to achieve a fit-for-purpose commissioning program, the following principles apply:

- The commissioning program should test separate operation of each component for the range of operation permitted under the performance standards (considering the extent that the component technologies (components) can be operated independently).
- Where one component relies on the other being in service (for example, a grid-following and grid-forming component or a steam turbine and gas turbine in a combined cycle plant), the commissioning program should consider them in service together, but also consider the required response when one component is disconnected<sup>43</sup> if the associated performance is captured in the plant's performance standards.
- The commissioning program should also consider tests for the operating level of the systems together, with a permissible combination of operation (for example, charging of a battery in conjunction with generation from a solar farm).

## 4.4. Plant alterations and testing settings changes

When developing a commissioning program for alterations to GS or IRS, AEMO recommends that Proponents familiarise themselves with the NER 5.3.9 Process Guideline<sup>44</sup> which includes guidance on information that must be provided, and assessments and approvals that must occur before commissioning of altered plant that is subject to the NER 5.3.9 process.

When developing a commissioning program for a plant alteration, the scope of testing should focus on the changes to the GS or IRS. The commissioning program should seek to confirm the performance of the plant in those areas for which changes were intended but also consider the risk of unintended changes. The same approach applies to scoping tests for settings changes under NER S5.2.2.

The use of checkpoints to confirm stability is recommended for rapid identification of unintended changes or consequences.

Hold point levels should be selected based on the impact of the whole system, not just the changes, but the scope of tests within the hold points and checkpoints should reflect the changes. In many cases, a reduced set of tests will be suitable for an alteration, rather than a full suite.

## 5. Undertaking commissioning

### 5.1. Pre-requisites for undertaking commissioning

#### 5.1.1. General

The following general items are required before the commissioning process can begin:

- Applicable registration and classification of the plant has been approved, and

---

<sup>43</sup> For example, there might be a runback or trip scheme for a partial trip of the grid-forming plant if the system strength mitigation relies on the operation of the grid-forming component.

<sup>44</sup> At <https://aemo.com.au/energy-systems/electricity/national-electricity-market-nem/participate-in-the-market/network-connections/transmission-and-distribution-in-the-nem/altering-a-generating-system-or-integrated-resource-system-ner-5-3-9-process>.

- The NSP has notified the Proponent that it agrees with the proposed commissioning times<sup>45</sup>.

Note that limited pre-commissioning test activities are permitted before registration, with a notifiable exemption<sup>46</sup>.

### 5.1.2. Documentation

Unless otherwise agreed in writing with the NSP and AEMO, the following documentation is required before the commissioning process can begin:

- Up-to-date R1 models and documentation<sup>47</sup>.
- The agreed commissioning program as required by NER 5.8.4.
- Trip, runback scheme and other control system reports (if applicable).
- Communication failsafe mechanism document (for GS and IRS controls that are operated through communication networks).
- Physical setting downloads of the PPC(s) and production unit controllers.
- Setting summary table comparing physical settings downloaded from plant controller(s) and production unit controllers on site with the R1 PSS®E and PSCAD™/EMTDC™ model settings.
- Valid calibration certificates of measurement equipment.
- Commissioning communications and test schedule (described in Section 5.4)
- If plant energisation is intended before registration, approval for auxiliary load.
- Pre-test simulation studies, as per the commissioning program (see next section).

## 5.2. Pre-test simulations

Pre-test simulations provide information on expected voltage impact at the connection point and the dynamic response of the plant. Documentation of impacts on nearby network and plant may also be required. Pre-test simulations are performed with the RMS R1 model of the plant for the anticipated network conditions at the time of commissioning, unless otherwise agreed with the NSP and AEMO. They should be provided ahead of testing (preferably at least two weeks ahead) to allow sufficient time for the NSP and AEMO to review.

The commissioning program should document the software package to be used, and which tests require pre-test simulations, focusing on those with dynamic responses and expected higher impact.

---

<sup>45</sup> NER 5.8.5(b)(2).

<sup>46</sup> Any testing with the plant connected to the power system, before registration, must be pre-approved under AEMO's notifiable exemption process. See Guide to Registration Exemptions and Production Unit Classification, at <https://aemo.com.au/consultations/current-and-closed-consultations/guide-to-generator-exemption-and-classification-of-generating-units-consultation>.

<sup>47</sup> R1 models (registered data pre-commissioning, as described in NER S5.5.2) and associated documentation including Releasable User Guide (RUG) and EMT model user guide, source code and block diagrams should be provided and approved before registration. If more up-to-date information is available, updates must be provided ahead of commissioning (in accordance with NER S5.2.4(d)).

### 5.3. Measurement equipment

Measuring equipment is installed to obtain data for the purposes of compliance and model validation during the commissioning process and for ongoing compliance validation. Where required by the performance standards, installation will be permanent.

Measuring equipment may use continuous monitoring, event triggering, manual triggering or other methods. The following requirements apply:

- Measurement ranges and trigger levels (if applicable) should be set appropriately for the expected range of tests and/or disturbances imposed on the GS or IRS.
- The sampling rate and time window should be adequate for the tests and/or expected range of disturbances imposed on the GS or IRS.
- For inverter-based technologies, high speed measurement equipment (typical sampling rate greater than 10 kilohertz (kHz)) is required to capture the dynamic response adequately.
- The data must be either in comma separated values (CSV) or COMTRADE format (C37.111-2013 ASCII format DAT preferred), or able to be reformatted into one of these formats, for transfer to the NSP and AEMO. Other data formats may be agreed between the NSP, AEMO and the Proponent.
- Measurements must be timestamped and where multiple recorders are used, measurement results must be synchronised (for example, to a global positioning system clock).
- For measurements taken during the commissioning process, measurement equipment and monitored plant must be in-service for all tests unless otherwise specified in the commissioning program.
- Measured voltages and currents must measure and record at least three-phase RMS and per-phase RMS values. It is recommended that measurement equipment with the capability to record three-phase instantaneous quantities is used to facilitate fault finding.
- Measurement equipment power should be supplied via an uninterruptable power supply (UPS) to ensure continuous recording during network disturbances.

### 5.4. Commissioning communication and test details schedule

The Commissioning communication and test details schedule is used to coordinate test activities between parties during the commissioning process. It is a live document updated during the commissioning process and includes:

- A communications matrix.
- A communications protocol.
- A commissioning timeline.
- A commissioning test schedule with corresponding plant operating profile (active power and reactive power).

The Commissioning Toolkit contains an editable Commissioning communication and test details schedule template<sup>48</sup>.

Commissioning test schedules and corresponding plant operating profile should be submitted to the NSP and AEMO commissioning support engineers, as per the agreed communications protocol, at least three business days (excluding day of submission and day of testing) before the planned testing<sup>49</sup>. All tests specified in the commissioning test schedule are to be accurately represented in the daily plant operating profiles and updated promptly when changes occur.

Note that test schedules must not be sent directly to AEMO operational control rooms.

The NSP may require additional data, such as expected voltage profiles.

#### 5.4.1. Dispatch, congestion and coordination considerations

The current system conditions and network outages that may affect commissioning should be considered when preparing the commissioning test schedule.

##### Current system congestion

AEMO publishes congestion information on its website<sup>50</sup>. Proponents should check with the NSP for advice on transmission and distribution limits and familiarise themselves with the area where their project is located and the likely impacts of commissioning activities on the surrounding network.

##### Network outage impacts

Network outages may limit the maximum permitted operating level of the plant during commissioning. Review of planned network outages during commissioning planning will help identify windows in a particular region where network outages are likely to affect commissioning. Planned outages are coordinated by the NSP. The latest information for the transmission network is stored in the Network Outage Schedule (NOS)<sup>51</sup>.

##### Dispatch

Dispatch of production units in the NEM during commissioning occurs in line with the NEM dispatch procedures<sup>52</sup>.

AEMO has also released a NEM Operational Forecasting and Dispatch Handbook for Wind and Solar Generators<sup>53</sup> which explains how semi-scheduled generators and non-scheduled intermittent generators with semi-scheduled obligations communicate current conditions and availability applicable to their plant.

---

<sup>48</sup> At <https://www.aemo.com.au/energy-systems/electricity/national-electricity-market-nem/participate-in-the-market/network-connections/transmission-and-distribution-in-the-nem/completion>.

<sup>49</sup> Some NSPs may have additional advanced notice requirements.

<sup>50</sup> At <https://aemo.com.au/energy-systems/electricity/national-electricity-market-nem/system-operations/congestion-information-resource>.

<sup>51</sup> At <https://aemo.com.au/energy-systems/electricity/national-electricity-market-nem/data-nem/network-data/network-outage-schedule>.

<sup>52</sup> At <https://aemo.com.au/energy-systems/electricity/national-electricity-market-nem/market-operations/dispatch-information>.

<sup>53</sup> At <https://aemo.com.au/energy-systems/electricity/national-electricity-market-nem/nem-forecasting-and-planning/operational-forecasting/solar-and-wind-energy-forecasting>.

The NSP, AEMO, and the Proponent must coordinate commissioning so as not to adversely affect other Registered Participants, power system security or quality of supply<sup>54</sup>. Where one or multiple simultaneous commissioning tests in an electrical area could have these impacts for certain power system conditions, the NSP, in consultation with AEMO, may reduce the amount of commissioning activity to the level necessary to avoid those impacts.

### **Inflexible bids during commissioning**

Where constraints are likely to bind, the use of inflexible bidding may be helpful depending on the nature of the test.

The AER has published a guideline on bidding<sup>55</sup> which explains the circumstances under which inflexible bidding is permissible. If the dispatch outcomes result in a constraint violation, the AEMO control room can cancel the test and request the participant to remove the inflexible bid or apply a system security constraint. Inflexible bidding for commissioning should only be used once all other options have been exhausted. AEMO recommends that the Proponent discuss with the AEMO Commissioning team before using inflexible bids. The AEMO Operations Planning team may or may not approve inflexible bidding depending on their assessment.

### **Coordinating testing with market systems and power system operations**

Before testing:

- The Proponent must submit bids and update limits and availability in the AEMO Market Management System (MMS), reflecting the test requirements.
- Unless otherwise agreed with AEMO and the NSP, before proceeding with each commissioning test, the Proponent must seek approval from the NSP control room and AEMO control room directly. Alternatively, where AEMO and the NSP agree, approval for the full day's testing may be sought from the NSP and AEMO control rooms before commencement of those tests.
- AEMO will invoke and revoke constraint equations based on the hold point or checkpoint level and NSP advice on commissioning testing.

Note that, despite any prior approval, tests may be cancelled without notice, if power system conditions at the time are unsuitable for testing.

## **5.5. Witnessing of tests**

Witnessing of tests, whether on-site or by remote monitoring, may assist to achieve a rapid turnaround of response for checkpoints, and resolution of issues as they arise. Remote witnessing is considered as effective as on-site witnessing, while optimising the cost and efficiency of NSP and AEMO commissioning resources. The Proponent should check with the NSP and AEMO whether they wish to witness any tests, noting they have a right to do so<sup>56</sup>. The NSP and/or AEMO will advise the Proponent if they plan to witness specific tests, before the day the tests are scheduled to occur.

---

<sup>54</sup> NER S5.8.2.

<sup>55</sup> At <https://www.aer.gov.au/industry/registers/resources/guidelines/rebidding-and-technical-parameters-guidelines>.

<sup>56</sup> Under NER 5.8.5(a).

## 5.6. Test day reporting requirements

The NSP and AEMO must be kept informed of the progress of commissioning<sup>57</sup>. At the end of each day of scheduled testing the following is required:

- The NSP and AEMO control rooms are notified as per their requirements.
- For checkpoints and hold points, reporting required to assess the CSF.
- A progress email should be sent to the NSP and AEMO commissioning representatives and include the following information:
  - The commissioning test log describing which tests were completed, the plant operating conditions and the timestamp of key aspects of the test, including application of controller setpoint changes or switching of plant (as applicable), and any operational restrictions at the time of testing. An example test log template is provided in the Commissioning Toolkit<sup>58</sup>.
  - Any deviations from the agreed commissioning schedule.
  - Any unexpected results, stability issues or potential non-compliance with performance standards.

## 5.7. Additional reporting requirements to finalise commissioning

### 5.7.1. Final commissioning report

All commissioning program test results and compliance assessments and agreed model overlays should be combined in one final commissioning report. Submission of the final hold point report may also be combined with the final commissioning report.

The reporting may be collated at the completion of testing. Alternatively, the parties may agree that all test results, assessment and model overlays can be compiled into a single live document, with version control, updated and reviewed progressively during the commissioning period.

Where changes have occurred during commissioning – for example, to controller settings or firmware – a short summary should be included in the report, specifying changes and how they relate to the test results.

A compliance summary should be included at the front of the report. The compliance for all tests must be reported, and any outstanding non-compliances must be documented and managed.

---

<sup>57</sup> Including promptly advising AEMO at the time that the Proponent becomes aware, of any circumstance which could be expected to adversely affect the secure operation of the power system or any equipment owned or under the control of the Proponent or the NSP, as required under NER 4.8.1 and 4.8.2.

<sup>58</sup> At <https://www.aemo.com.au/energy-systems/electricity/national-electricity-market-nem/participate-in-the-market/network-connections/transmission-and-distribution-in-the-nem/completion>.

### 5.7.2. System event analysis and reporting

For any relevant system event(s) during the commissioning period, the final commissioning report should include measurement plots, including model overlays if specified in the commissioning program, and analysis of the plant's performance standards compliance<sup>59</sup>.

For model overlay purposes, 'playback' of measurements to emulate the grid voltage and/or frequency in a simulation may be used. Examples of relevant system events include nearby network faults and large generation or load trips.

## 5.8. Managing changes during commissioning

Changes may need to be made to the commissioning program during commissioning for reasons such as construction program delays, inadequate energy source availability or setting changes due to misalignment between performance and model simulations. The Proponent should advise the NSP and AEMO of proposed changes as soon as practicable, so that the commissioning program and test schedule can be amended, and resourcing impacts managed efficiently.

Small changes (for example, adjustments in MW output, units in service or other pre-test conditions) may be approved by the NSP and AEMO via email to minimise delays. For more significant changes the Proponent may need to submit an amended commissioning program and test schedule for approval.

### 5.8.1. Delays to completion of testing

If the completion of testing is delayed by more than a few weeks<sup>60</sup>, the commissioning program should be revised to finalise testing at the maximum level achievable at that stage. To remain operating at this level, the Proponent will be required to:

- Complete hold point tests that were originally programmed for a higher operating level (where feasible).
- Complete and submit test reporting.
- Address (or otherwise manage) any outstanding non-compliances, and
- Submit R2 model validation within three months of completion.

Ahead of resumption of commissioning, the Proponent should discuss with the NSP and AEMO the remaining work to complete the commissioning program, with a view to achieving outcomes that are fit-for-purpose, considering the impact of the plant on the power system and any additional testing conducted at the interim maximum operating level.

### 5.8.2. Inadequate energy source or unit unavailability

Plant operating levels may be impacted by test conditions during commissioning including, but not limited to:

---

<sup>59</sup> The absence of a relevant system event during the period does not prevent the plant from being released to full operation. Ongoing compliance should be assessed when relevant system events occur over the life of the plant.

<sup>60</sup> For example, due to construction or equipment supply delays.

- Energy source availability (for example, solar irradiance over winter), and
- Unit availability (for example, wind turbines or inverters out of service for maintenance).

By default, the pre-test conditions defined in the commissioning program should be met. However, the parties may agree to undertake testing at a lower output or reduced number of units on a case-by-case basis to reduce commissioning delays. Factors to consider include:

- Sensitivity to operating level – if the test outcome is insensitive to operating level, it can be completed at a lower level. If final hold point tests are impacted by energy source availability, parties may agree to proceed at the lower level and release the plant to full output following this testing. However, there is an expectation that additional testing at full output will be undertaken when the energy source is available. Also, if the commissioning is impacted at any CP or HP (other than final HP) due to energy source availability, parties may agree to adjust CP or HP output level based on the available energy source forecasts.
- Sensitivity to unit availability – if the test outcome is insensitive to number of units, it can be completed with fewer units online. Parties may then agree to proceed to a higher output with fewer units online. If the outcome is sensitive to the number of units, additional testing may be required when the units are returned to service.
- Difference between proposed test conditions and available test conditions – small differences are easier to accommodate as the outcome difference is less likely to be material.
- Plant impact – reduced operating levels or unit availability can be more readily accommodated for low impact plant.

### 5.8.3. Setting changes

Control system setting or firmware updates may be required during commissioning to address:

- Incorrect application of settings, leading to a model-measurement mismatch, or
- Unforeseen performance issues, particularly anything causing the plant to operate unstably or with poor damping.

The Proponent may only apply setting changes that have been approved in writing by the NSP and AEMO<sup>61</sup>. Changes to firmware or settings which impact performance are managed through the NER 5.3.9 process<sup>62</sup> as outlined in Section 4.4 (for alterations) or NER S5.2.2 (for settings changes). In either case, the change process should be efficient and proportionate to the scope of the change.

## 5.9. Managing adverse security impacts and non-compliances during commissioning

Plant should be monitored constantly and, as per NER 4.8.1 and 4.8.2, the Proponent must immediately report to the AEMO control room on observing any abnormal behaviour that could be expected to affect the secure operation of the power system or the Proponent's or NSP's equipment, as well as any

---

<sup>61</sup> NER S5.2.2.

<sup>62</sup> NER 5.3.9.

defects or unavailability of applicable protection or control systems. Note that this obligation continues to apply when the plant moves from commissioning into full operation.

Commissioning tests may reveal that the GS or IRS performance does not meet the agreed performance standards. The NSP and AEMO should be notified immediately when a non-compliance is observed in testing. Non-compliances must be resolved or managed before release to full operation<sup>63</sup>. For management of an unresolved non-compliance, a notice of non-compliance<sup>64</sup> must be lodged with AEMO, including the management plan agreed with the NSP and AEMO.

Management of non-compliances must avoid or minimise potential adverse impacts on power system security, achievement of system standards and quality of supply to other users. If a non-compliance does not have an adverse impact<sup>65</sup>, the parties may agree to negotiate an amendment to the relevant performance standard<sup>66</sup>. The NSP and AEMO may consider any practical challenges raised by the Proponent when considering the appropriate assessment and remediation of a non-compliance.

### **Instability or poor damping**

Where instability or inadequate damping is detected, the plant's operating level must immediately be reduced to a stable level and the NSP and AEMO should be promptly notified<sup>67</sup>. All high-speed data and SCADA pertaining to the incident must also be downloaded and provided to the NSP and AEMO as soon as possible to facilitate investigation<sup>68</sup>.

As rectification of unstable/poorly damped operation is likely to result in the need for control system changes (for example, settings or firmware), this type of performance issue must be investigated and rectified before conducting further testing.

Under some circumstances, the NSP, in consultation with AEMO, may permit operation in an alternative operating mode (for example, power factor control) while the non-compliance is being resolved, provided the plant has been tested and is stable in this mode of operation.

### **Other non-compliances**

In the case of other security-related non-compliances<sup>69</sup> within hold points, where feasible, the Proponent should resolve the matter before proceeding to a higher operating level or additional units.

More generally, depending on the nature of the non-compliance, and the impact of the plant on the power system, the NSP, in consultation with AEMO, may permit the plant to resume testing after lodgement of a non-compliance notice with an agreed management plan to rectify the non-compliance.

If AEMO assesses the non-compliance has or could have an adverse impact on power system security, or the NSP assesses it has or could have an adverse impact on quality of supply to other network users,

---

<sup>63</sup> Or release to reduced operation if applicable.

<sup>64</sup> See <https://aemo.com.au/energy-systems/electricity/national-electricity-market-nem/system-operations/generator-performance-standards>.

<sup>65</sup> Materiality should be considered when determining whether a non-compliance has an adverse impact.

<sup>66</sup> The performance standard must satisfy the requirements of a negotiated access standard under NER 5.3.4A(b).

<sup>67</sup> As per NER 4.8.1 and 4.8.2.

<sup>68</sup> Some data sources, such as high-resolution SCADA data or inverter-level internal data, may be lost if not downloaded promptly.

<sup>69</sup> For example, incorrect operation of a run-back or inter-trip scheme.

it may be necessary to impose operational restrictions on the plant to mitigate the impact, until the performance is rectified.

## Appendix A. Examples of default test categorisation

The following tables provide tests that are categorised by default as preliminary tests, hold point tests, checkpoint tests and flexible tests.

A test's category may be varied from the default category. These tables may not cover all tests required in a commissioning program. The inclusion of a test in this appendix does not imply it must be included in a commissioning program. Parties should consider the category descriptions in this Guideline when deciding whether to assign a test to one of these categories. See Section 3 for more information on the categories and how they apply.

**Table 1 Preliminary tests**

Test	Description	Purpose
<b>Tests for synchronous machines</b>		
<b>Synchronous machine offline step response test</b>	Voltage control setpoint steps with machine offline.	Confirm stability and compliance for NER S5.2.5.13 for offline performance (which also affects stability once plant is online). To confirm machine and excitation system modelling parameters.
<b>Synchronous machine open circuit characteristic tests</b>	Machine runs offline at rated speed with automatic voltage regulator (AVR) in manual operation. Terminal voltage is varied in small increments over a wide range.	Verify machine saturation characteristics (affects NER S5.2.5.13 compliance).
<b>Synchronous machine speed response test</b>	With machine running offline at rated speed, apply positive and negative steps to governor speed reference set point.	Confirm stable operation, ability to follow speed reference signal correctly to verify turbine-governor model parameters.
<b>Synchronous machine valve response tests</b>	With synchronous machine at standstill with valve/gate positioning enabled, apply step to valve/gate position reference.	Confirm valve follows setpoint command and response is adequately damped (NER S5.2.5.14). To validate governor model parameters.
<b>Volts (V)/Hz limiter</b>	With the machine offline, at rated speed. Speed is gradually reduced or voltage reference increased until V/Hz limiter operates.	Confirm V/Hz limiter operation (NER S5.2.5.3 compliance) and control operation is adequately damped for these conditions (part of NER S5.2.5.13 compliance). To confirm limiter operation against model.
<b>Off-line frequency sweep (transfer function tests)</b>	With the synchronous unit not running and excitation system offline, frequency response of the excitation system is assessed over a frequency bandwidth of at least 0.01-10.0 Hz by injecting sinusoidal signals with the specific bandwidth into the control blocks.	Validate the transfer function block diagram of the AVR and Power System Stabiliser.
<b>Tests for IBR technologies</b>		
<b>End to End communications delay tests</b>	Measure signal delays between central controller and production units, reactive power ancillary devices.	Confirm communication signals and feedback and validate communication delays.

Test	Description	Purpose
		Communication delays can impact stability of control systems (NER S5.2.5.13 and S5.2.5.14). Confirm communications delays are consistent with dynamic modelling.
<b>Unit signal injection tests</b>	Signal injections to confirm protection settings (voltage and frequency) are correctly applied.	Confirm voltage and frequency protection settings (NER S5.2.5.8). To confirm unit protection settings are consistent with dynamic models.
<b>Instability monitoring</b>	Secondary injection test.	Confirm the operation of the stability monitoring with correct thresholds triggering corresponding actions (part of NER S5.2.5.10).
<b>Tests common to synchronous machines and IBR technologies</b>		
<b>Auxiliary dynamic reactive plant control system test</b>	Step primary operating mode reactive power setpoint control into limits and not into limits.	Confirm the reactive power control stability and capability of dynamic / static reactive devices within a GS or IRS.
<b>Background power quality measurements<sup>A</sup></b>	Measurement of background harmonic levels at the connection point before energisation of the GS or IRS.	Used in conjunction with online measurements to calculate harmonic emissions (NER S5.2.5.2).
<b>Functionality testing between central controller and single production unit</b>	Limited operation of one production unit from central controller (plant with small units, typically < 5 MW).	Testing of the SCADA to central controller interface. (NER S5.2.6.1).
<b>SCADA point to point testing<sup>B</sup></b>	Confirmation of SCADA signals between the GS/IRS, NSP and AEMO.	Confirm remote monitoring and control functions (NER S5.2.6.2) which are also required for NER S5.2.5.14 and NER S5.2.5.13 (for market dispatch and VAR Dispatch Scheduler respectively). Remote monitoring signals may also be required for NER S5.2.5.10.
<b>Runback scheme tests</b>	Communications tests.	Confirm that communications between stations are functioning.
<b>Unit reactive power test (small units typically &lt; 5 MW)</b>	Gradually increase reactive power injection and absorption to confirm unit capability limits (plant with small units, typically < 5 MW).	Confirm unit reactive power capability against expected (R1 model) capability.

A. Note that background power quality and power quality tests are generally required for non-synchronous plant. Power quality tests might be required for synchronous plant might be required in some circumstances, for example, intermittent generation that exhibits rapid or frequent output changes.

B. AEMO requires verification of SCADA to be carried out before registration unless otherwise agreed.

Table 2 Checkpoint tests

Test	Description (abridged)	Purpose <sup>A</sup>
<b>Test for IBR technologies</b>		
<b>Active power step test (local control)</b>	Step active power reference down and up.	Confirm the stability of the active power loop.
<b>Reactive power reference step test<sup>B</sup></b>	At agreed level of active power step reference setpoint in both directions (not into a limiter).	Confirm stability of the reactive power loop.
<b>Tests common to synchronous machines and IBR technologies</b>		
<b>Primary mode reference step test (not into a limiter)</b>	Test to be completed for primary operating mode (voltage control, power factor, or reactive power). At agreed level of active power step reference setpoint in both directions (not into a limiter). Typically, 3% or 5% voltage reference steps, or steps that result in equivalent reactive power step.	Confirm stability of plant response for reference step.
<b>Primary mode reference step tests (into a limiter) (also, over excitation limiter [OEL] and under excitation limiter [UEL] tests for synchronous machines)</b>	Test to be for primary operating mode (as above). At agreed level of active power, step reference setpoint in both directions into a limiter. Typically step away from the limit by a small step, then into the limiter with a larger step.	Confirm stability of plant response for reference step, into limit.

A. When these test are used in hold points, they are used to check compliance with relevant performance standards as well as stability.

B. Stability of the reactive power can alternatively be tested with a voltage reference step test (listed under 'Primary mode reference test not into a limiter').

Note: Default hold point tests include those listed in Table 2 above, as well as Table 3 below.

Table 3 Hold point tests

Test	Description (abridged)	Purpose
<b>Tests for synchronous machines</b>		
<b>Field voltage ceiling</b>	With machine at rated output and rated power factor, apply a voltage impulse to the voltage reference setpoint sufficiently large to reach excitation ceiling voltage.	Confirm compliance with NER S5.2.5.13 for ceiling voltage.
<b>Stator current limiter (SCL) test</b>	With machine just operating at SCL step voltage reference away from limit by 2.5% then into limit by 5%.	Confirm stability of plant response for settling time into a limit. Confirm compliance with NER S5.3.5.13.

Test	Description (abridged)	Purpose
<b>Partial load rejection</b>	Manually trip the unit by opening the machine circuit breaker. Monitor the plant response. The machine must be returned to a stable off-line operating condition after the load rejection.	Confirm compliance with NER S5.2.5.7. Confirm synchronous machine excitation and governor model parameters for model validation.
<b>Tests for IBR technologies</b>		
<b>Communications failure test</b>	For systems with a plant controller, check fail-safe shutdown process for loss of signal between plant controller and units.	Confirm fail safe operation (communications failure can lead to unstable operation in some circumstances, and failure to follow dispatch). The test may also be required to confirm compliance with one aspect of NER S5.2.5.10.
<b>Wind free<sup>70</sup> operation/night-time solar operation – reference steps into limiter (all units in service)<sup>A</sup></b>	Where a wind farm or solar farm provides voltage control (or other reactive power control) below the energy source level for minimum active power output, conduct reference steps into reactive power limiters.	Confirm stable operation in accordance with NER S5.2.5.13 requirements, for the arrangements agreed in NER S5.2.5.1.
<b>Wind free operation/ night-time solar operation reference steps not into limiter (all units in service)<sup>A</sup></b>	Where a wind farm or solar farm provides voltage control (or other reactive power control) below the energy level for minimum active power output, conduct reference steps, not into a limiter.	Confirm stable operation in accordance with NER S5.2.5.13 and performance standards compliance requirements for the arrangements agreed in NER S5.2.5.1.
<b>Tests common to synchronous machines and IBR technologies</b>		
<b>Active power dispatch test (through NEM dispatch)</b>	From agreed active power level, through dispatch system apply steps to dispatch level in both directions.	Confirm ability of plant to follow dispatch instructions correctly (ramping linearly to dispatch target over dispatch interval) (NER S5.2.5.14).
<b>Auxiliary plant switching test – static reactive plant – dynamic reactive plant</b>	Switch a static reactive element (such as a filter bank) or trip a dynamic reactive plant (e.g. SC, static synchronous compensator) within the GS/IRS. Monitor the response of the remaining plant.	Confirm switching controls and reactive capability. Confirm compliance with NER S5.2.5.13 for adequately damped response. Confirm compliance with any required trip or run-back arrangement (NER S5.2.5.8 or NER S5.2.5.12).
<b>External reactive plant switching test</b>	System operator switches out and switches in a reactive plant element (such as a reactor or capacitor) or steps a static VAR compensator (SVC). Monitor response of the GS/IRS.	Confirm stable response to external disturbance, consistent with NERS5.3.5.13. Confirm compliance against NER S5.2.5.4 for continuous uninterrupted operation. Confirm response against dynamic model.
<b>Line switching test</b>	System operator switches a line external to the GS/IRS. Monitor the response of the GS/IRS.  This test may also incorporate a reference step test with the line out of service to test a lower system strength condition.	Confirm stable response to external disturbance, consistent with NER S5.3.5.13. Confirm compliance against NER S5.2.5.4 for continuous uninterrupted operation.

<sup>70</sup> Operation of a wind turbine for wind level below its minimum operating level for active power production.

Test	Description (abridged)	Purpose
		Confirm response against dynamic model. Partially confirm compliance against NER S5.2.5.15.
<b>Trip or runback scheme test</b>	Trigger conditions for run-back via actual conditions or secondary injection. Monitor response of the plant.	Confirm compliance with NER S5.2.5.8/12 conditions.

A. This test could be in the flexible test category for low impact plant.

**Table 4 Flexible tests**

Test	Description (abridged)	Purpose
<b>Tests for IBR technologies</b>		
<b>Feeder trip test</b>	For plant with multiple internal feeders in the collector system, trip one feeder.	Confirm that the plant controller correctly adjusts the output of remaining units. Partial test of compliance with NER S5.2.5.13.
<b>Internal reactive plant switching (algorithm check)</b>	Test the reactive plant within the GS/IRS switches as expected.	Confirm operation of the reactive plant switching for NER S5.2.5.1 and NER S5.2.5.2 compliance.
<b>Voltage/reactive power with reduced units in service<sup>A</sup> at night (solar farms)</b> – reference step test not into a limiter – reference step test into a limiter	Where a solar farm provides voltage control (or other reactive power control) below the energy level for minimum active power, conduct agreed operating mode reference steps in both directions. Test steps not into a limiter and into and from a limiter.	Confirm compliance with NER S5.2.5.1 for system when units are not otherwise in service.
<b>Tests common to synchronous machines and IBR technologies</b>		
<b>Automatic generation control (AGC) test</b>	Test response to AGC signals for dispatch.	Confirm compliance with NER S5.2.5.14 for dispatch using AGC.
<b>Power quality test<sup>B</sup></b>	Continuous measurement of power quality (harmonics, flicker and unbalance) at the connection point over a specified period (typically 1-2 weeks) as agreed with NSP.	Confirm compliance with NER S5.2.5.2 for harmonics, flicker and unbalance. Partial check compliance against NER S5.2.5.6.
<b>Reactive power capability</b>	Gradually adjust reactive power level to establish steady state reactive power limits for conditions specified in NER S5.2.5.1.	Confirm reactive power capability at a specified level of active power for compliance with NER S5.2.5.1.
<b>Secondary operating mode reference step test</b>	At agreed level of active power step reference setpoint in both directions (not into a limiter), for reactive power step specified in the NER S5.2.5.13, or other agreed amount.	Confirm compliance with NER S5.2.5.13 for secondary operating mode, settling time and regulation accuracy.
<b>Secondary operating mode reference step into a limiter<sup>C</sup></b>	At agreed level of active power step reference setpoint in both directions into a limiter, for reactive power step specified in the NER S5.2.5.13 or other agreed amount.	Confirm compliance with NER S5.2.5.13 for secondary operating mode settling time, for operation into a limiter.

Test	Description (abridged)	Purpose
<b>Temperature dependent active power local limit test</b>	Apply a bias to the temperature signal at the park controller (or unit, as applicable) to synthesise an increase in temperature that will derate the plant.	To assess accuracy of temperature dependent local limit calculation to meet NER S5.2.5.1 and NER S5.2.5.4.
<b>VAr dispatch scheduling system (VDS) test</b>	Apply a reactive power change through AEMO VDS and measure response of plant.	Confirm compliance with NER S5.2.5.13 requirement for remote control of the system.
<b>Primary frequency response (PFR) tests</b> <b>Frequency control ancillary services (FCAS) tests<sup>C, D</sup></b>	Frequency response step tests use signal injection to simulate frequency excursions. Monitor the plant response.  PFR tests also examine frequency responsiveness in conjunction with dispatch ramping using simulated and actual system frequency, and coordination with local limits.	Confirm compliance with NER S5.2.5.11 frequency responsiveness and NER S5.2.5.8 emergency over-frequency response, and confirm primary frequency response (PFR).  Confirm continuous uninterrupted operation for NER S5.2.5.3.  Confirm capability to participate in FCAS markets for NER S5.2.5.11.

- A. That is, the plant compensates the steady state reactive power from cables and other equipment within the connection when it is not generating active power, by keeping a small number of units in service to provide reactive power. The relevant operating mode is specified in the connection agreement, typically as either reactive power control or voltage control.
- B. Note that background power quality and power quality tests are generally required for non-synchronous plant. Power quality tests might be required for synchronous plant might be required in some circumstances, for example, intermittent generation that exhibits rapid or frequent output changes.
- C. The plant must not operate for an extended period in reactive power mode without first confirming the operation into limiters.
- D. For FCAS market participation, additional testing may be required to confirm integration with dispatch.

## Appendix B. Example risk assessment

A commissioning program must identify potential risks arising from carrying out each test and describe the applied risk mitigation controls. It is recommended that the Proponent’s test lead/manager sign-off on a completed risk matrix and the effectiveness of each risk control before each test commences.

The tables below provide an example of a risk matrix assessment framework and some sample risk assessments for selected tests. These are illustrative only. Proponents will need to identify and assess the key risks in the manner that is most appropriate to each commissioning test for their plant, given its specific circumstances and conditions.

**Table 5 Risk matrix example**

Probability of occurrence <sup>A</sup>	Severity of consequence <sup>B</sup>			
	Insignificant	Minor	Moderate	Major
Most likely	Medium	High	Extreme	Extreme
Likely	Medium	Medium	High	Extreme
Unlikely	Low	Medium	Medium	High
Most unlikely	Low	Low	Medium	Medium

- A. You may define the probability of occurrence, for example, most likely (more than 80% chance of occurrence).
- B. You may define the severity of consequence, for example, insignificant (commissioning program delay less than one week, cost overrun up to 10%, minimum rework to address the issue).

**Table 6 Risk assessment example – voltage reference step test**

Risk event	Likelihood	Consequence	Risk score
Non-compliance with work health and safety requirements	Unlikely	Major	High
Voltage outside the equipment withstand level	Unlikely	Moderate	Medium
Connection point voltage outside the normal operating level	Likely	Insignificant	Medium
Unexpected protection trip due to incorrect setting or malfunction	Unlikely	Insignificant	Low
Instability of the plant during the test	Unlikely	Major	High

**Table 7 Risk controls example – voltage reference step test**

Item no	Risk controls	Review
1	Commissioning lead/manager in attendance at all times	
2	Commissioning engineer in direct line of sight and communication at all times	
3	Confirm all plant quantities are within normal equipment withstand levels	
4	Confirm step size and reference change consistency with the commissioning program	
5	Communicate with the NSP and AEMO control room to configure network reactive plants, online tap changer and other voltage control equipment to allow tests to be conducted as required	

Item no	Risk controls	Review
6	Any deviation to the commissioning program pre-approved and appended to the commissioning program	

**Table 8 Risk assessment example – partial generating system trip test**

Risk event	Likelihood	Consequence	Risk score
Non-compliance to work health and safety requirements	Unlikely	Major	High
Voltage outside the equipment withstand level	Likely	Major	Extreme
Connection point voltage outside the normal operating level	Unlikely	Insignificant	Low
Instability of the plant during the test	Unlikely	Major	High

**Table 9 Risk controls example – partial generating system trip test**

Item no	Risk controls	Review
1	Commissioning lead/manager in attendance at all times	
2	Commissioning engineer in direct line of sight and communication at all times	
3	Confirm all plant quantities are within normal equipment withstand levels	
4	Ensure no personnel are located near production units, in case of explosive failure	
5	Any deviation to the commissioning program pre-approved and appended to the commissioning program	

## Appendix C. Example measurement point layout

As part of the commissioning program, the location of measurement equipment should be marked on a single line diagram, similar to the example shown in Figure 3.

**Figure 3 Measurement point layout example**

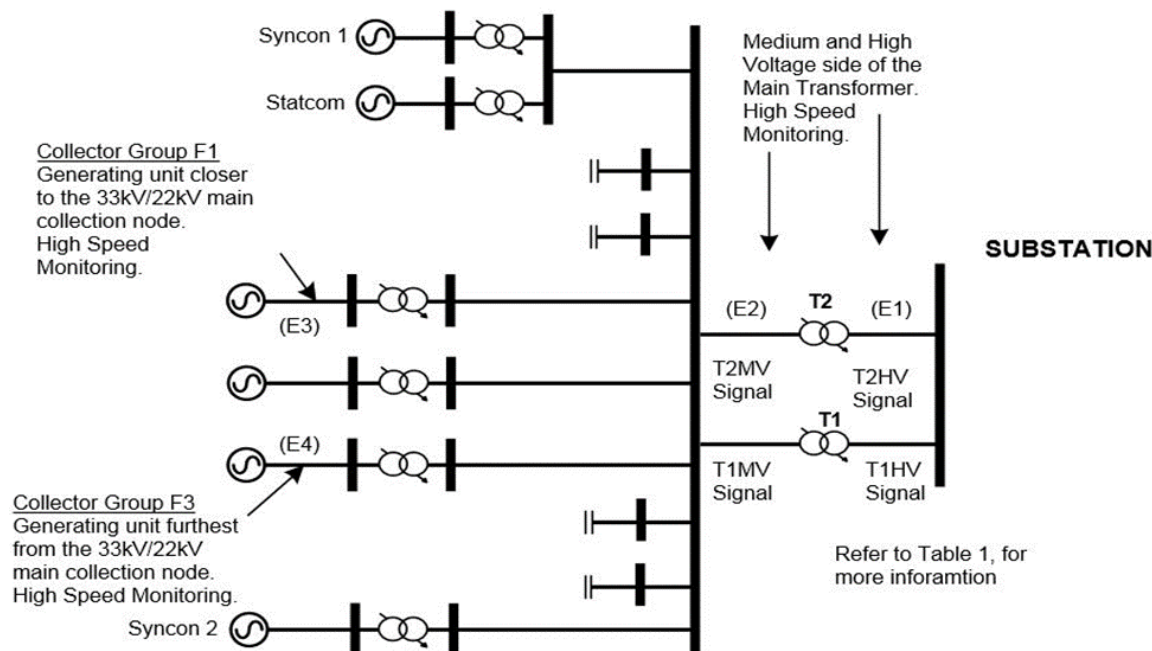

Typical monitor locations include:

- Connection point (essential).
  - If there are multiple connection points, a monitor will be needed at each connection point.
- Medium voltage (MV) collector bus to which the production units are connected (if applicable).
- Production units:
  - For distributed plant, at least one for each different type of PU and at both the electrically closest and furthest PUs with respect to the MV collector bus. As an example, a wind farm comprising 3 MW type 3 wind turbine generators (WTGs), 3 MW type 4 WTGs, and 2 MW type 4 WTGs would need to have at least one monitor for each of the 3 turbine types, covering closest and furthest turbines. A fourth monitor would be required if closest and furthest turbines were of the same type.
  - For plant with multiple units that can be operated independently (typical for synchronous generating systems), each unit should have a monitor recording its terminal quantities.
- Each type of dynamic reactive power device, such as STATCOMs and SCUs.