

# POWER SYSTEM OPERATING INCIDENT REPORT

## SIMULTANEOUS TRIP OF 97K COOMA – MUNYANG AND 97G GUTHEGA – MURRAY 132 KV LINES ON 5 JULY 2011

PREPARED BY: Electricity System Operations Planning and Performance

VERSION: 1.0

DATE: 8 December 2011

FINAL

## Disclaimer

### Purpose

This report has been prepared by the Australian Energy Market Operator Limited (**AEMO**) for the sole purpose of meeting obligations in accordance with clause 4.8.15 (c) of the National Electricity Rules.

### No reliance or warranty

This report contains data provided by third parties and might contain conclusions or forecasts and the like that rely on that data. This data might not be free from errors or omissions. While AEMO has used due care and skill, AEMO does not warrant or represent that the data, conclusions, forecasts or other information in this report are accurate, reliable, complete or current or that they are suitable for particular purposes. You should verify and check the accuracy, completeness, reliability and suitability of this report for any use to which you intend to put it, and seek independent expert advice before using it, or any information contained in it.

### Limitation of liability

To the extent permitted by law, AEMO and its advisers, consultants and other contributors to this report (or their respective associated companies, businesses, partners, directors, officers or employees) shall not be liable for any errors, omissions, defects or misrepresentations in the information contained in this report, or for any loss or damage suffered by persons who use or rely on such information (including by reason of negligence, negligent misstatement or otherwise). If any law prohibits the exclusion of such liability, AEMO's liability is limited, at AEMO's option, to the re-supply of the information, provided that this limitation is permitted by law and is fair and reasonable.

## Abbreviations and Symbols

Abbreviation	Term
AEMO	Australian Energy Market Operator Ltd
CB	Circuit Breaker
EST	Eastern Standard Time
kV	kilovolt
MW	megawatt
MWh	megawatt hour
NEM	National Electricity Market
NER	National Electricity Rules

© 2011 Australian Energy Market Operator Ltd. All rights reserved

# 1 Introduction

On 5 July 2011 a multiple contingency event occurred in New South Wales. At 1027 hrs on this day the 97K Cooma – Munyang 132 kV transmission line tripped, auto-reclosed, tripped and locked out at both ends. At the same time the 97G Guthega – Murray 132 kV transmission line tripped at the Murray end only. Approximately 18 MW of Perisher load supplied from the Munyang 132 kV substation was interrupted. Severe wind conditions were reported in the vicinity at the time.

This report has been prepared under clause 4.8.15 of the National Electricity Rules (NER) to assess the adequacy of the provision and response of facilities and services and the appropriateness of actions taken to restore or maintain power system security.

This report is largely based upon information provided by TransGrid. Data from AEMO’s Energy Management System have also been used in analysing the incident.

All references to time in this report are National Electricity Market time (Eastern Standard Time).

# 2 Pre-Contingent System Conditions

The status of the power system prior to the incident is shown in Figure 1. For clarity only equipment relevant to this incident has been included in the diagram.

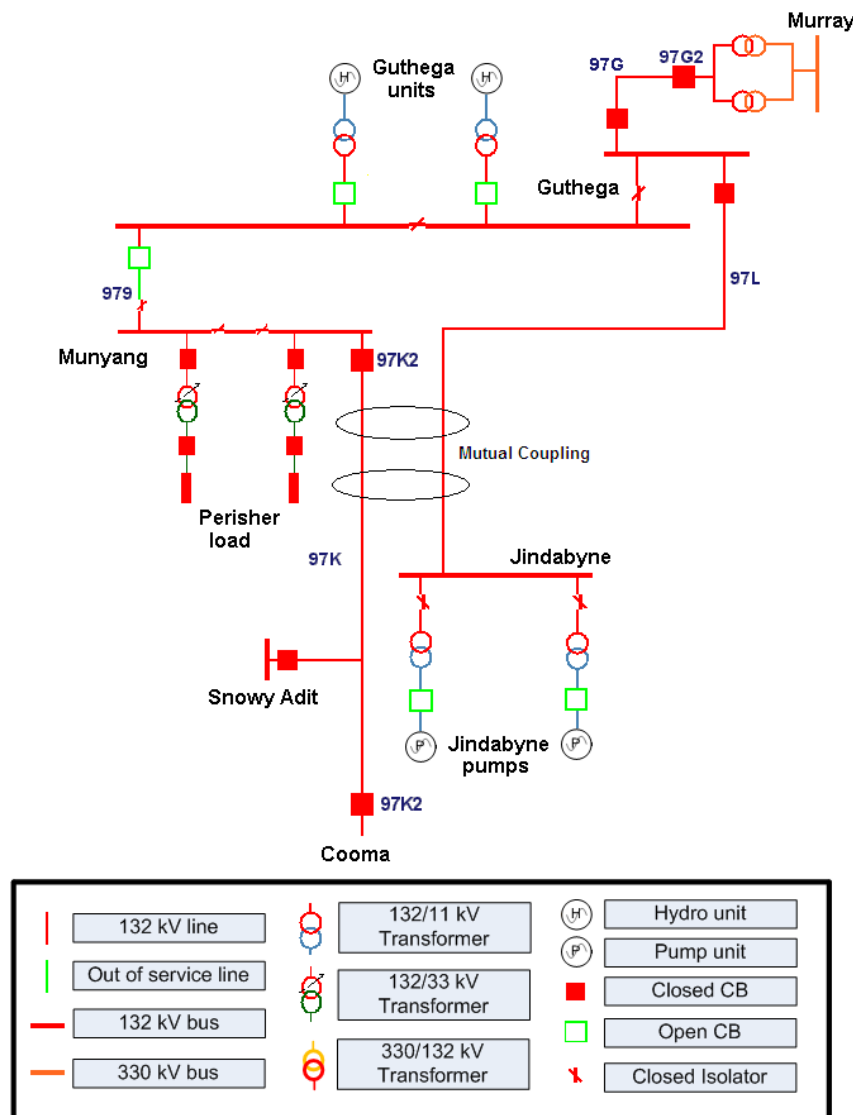

Figure 1 – Status of the power system prior to the incident

Note that the two Guthega generating units and two Jindabyne pumps were not in service at the time. As per TransGrid’s normal operating practice, the 979 Guthega – Munyang 132 kV line was open at the Guthega end.

### 3 Summary of Events

At 1027 hrs on 5 July 2011 the 97K Cooma – Munyang 132 kV line tripped, auto-reclosed, tripped and locked out at both ends. This resulted in the interruption of approximately 18 MW of Perisher load supplied from the Munyang substation. At the same time the 97G Guthega – Murray 132 kV line tripped at the Murray end only, de-energising the 132 kV lines to the Guthega generating units and Jindabyne pumps which were not in service.

The status of the power system immediately after the incident is shown in Figure 2.

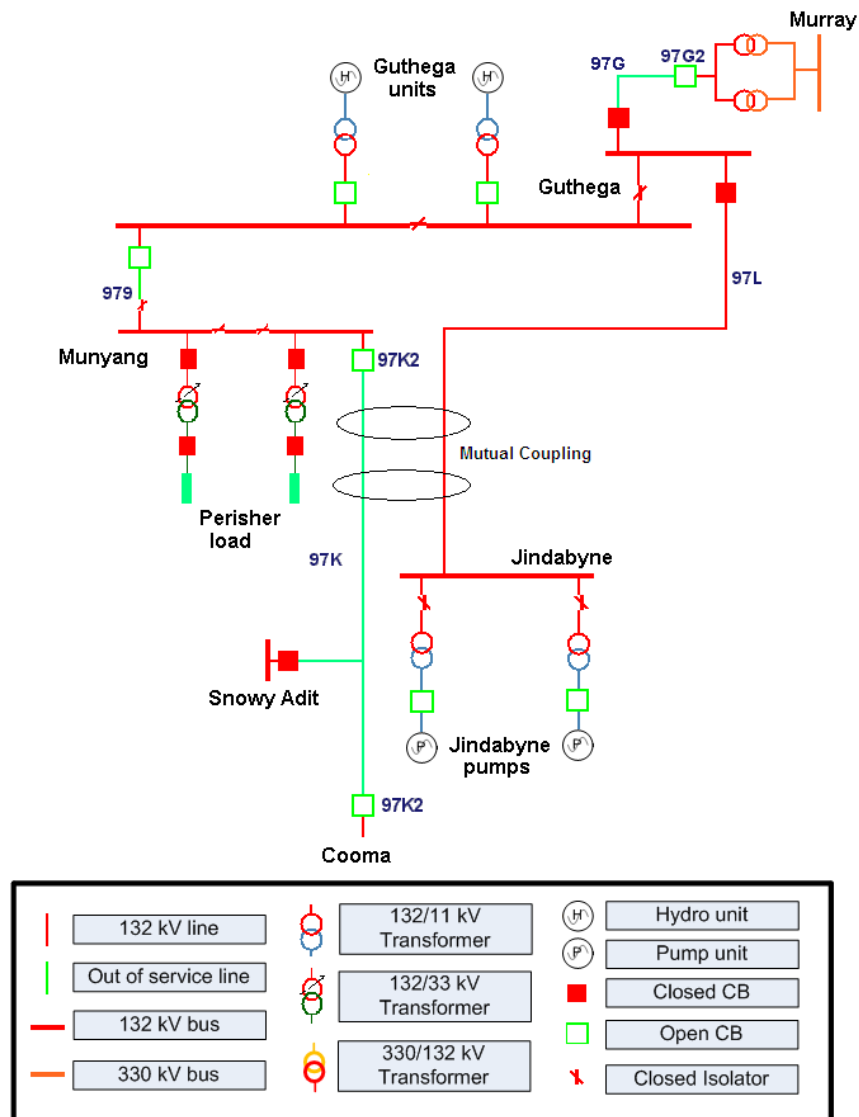

Figure 2 - Status of the power system immediately after the incident

### 4 Immediate Actions Taken

TransGrid investigated the trip of the 97K Cooma – Munyang 132 kV line and found that both distance protection systems at the Cooma 132 kV substation operated on detection of a zone 2 fault. The No. 1 protection at Cooma indicated a distance of 69 km to the fault, which was indicative of a fault in the vicinity of the Snowy Adit to Munyang section of the line. TransGrid

undertook a line patrol but this was limited to the first ten spans from Snowy Adit towards Munyang due to severe weather conditions. No evidence of a fault was found during that patrol.

TransGrid also found that the 97G Guthega – Murray 132 kV line tripped at Murray end on operation of the No. 2 directional earth fault (DEF) protection system at the Murray substation. The auto-reclose function is not available on this line. TransGrid assessed the cause of trip of 97G line and determined that the line could be returned to service. At 1038 hrs the line was returned to service.

TransGrid then closed the 979 Guthega – Munyang 132 kV line to supply the Perisher load from the Murray 132 kV substation and the load restoration was completed at 1049 hrs.

At 1621 hrs the 97K Cooma – Munyang 132 kV line was returned to service after the partial line patrol did not find evidence of a fault, as the most practical approach to restoring the power system. At the same time, the 979 Guthega – Munyang 132 kV line was re-opened at the Guthega end.

## 5 Follow-up Actions

TransGrid investigated the incident further, and found that the mutual coupling between the 97K Cooma – Munyang and 97L Guthega – Jindabyne 132 kV lines on the Snowy Adit to Munyang line section resulted in an induced earth fault current on 97L line during an earth fault on the 97K line. The induced earth fault current on 97L line continued via the 97G Guthega – Murray 132 kV line and the neutral earth points of the Jindabyne 132/33 kV and Murray 330/132 kV transformers.

The level of earth fault current on the 97G line was above the trigger setting of the DEF protection relay at Murray substation. Further, the time delay setting of the DEF protection relay was less than the distance protection zone 2 clearance time of the 97K line.

At 1625 hrs on 6 July 2011 AEMO issued Electricity Market Notice No. 35565 declaring the simultaneous trip of the 97K Cooma – Munyang and 97G Guthega – Murray 132 kV lines as a credible contingency event, pending further advice from TransGrid.

TransGrid has since reviewed and revised the settings for the 97G line protection systems at Murray substation, by increasing the time delay of the DEF protection relay to grade over the distance protection zone 2 clearance time of the 97K line.

At 1023 hrs on 10 August 2011 AEMO issued Electricity Market Notice No. 35816 cancelling its reclassification of the trip of the 97K and 97G lines as a credible contingency event, following advice from TransGrid of the revised protection settings.

On 26 September 2011 TransGrid completed its aerial patrol of the 97K line. No evidence of a fault was found.

## 6 Power System Security Assessment

The power system remained in a secure operating state throughout the incident and voltages and frequencies remained within their normal operating bands.

## 7 Conclusions

The incident was caused by protection operations to clear an earth fault on the 97K Cooma – Munyang 132 kV line and an induced earth fault on the adjacent 97L Guthega – Jindabyne 132 kV line at a time of severe wind conditions in the area.

The 97K line protection systems operated correctly, but TransGrid identified and subsequently rectified grading issues with the 97G line protection systems.

AEMO is satisfied that TransGrid carried out the necessary checks before returning the affected equipment to service. All affected equipment were returned to service promptly after the incident.

TransGrid has confirmed to AEMO that there are no other lines within its network that are likely to trip due to induced earth fault currents.

AEMO is satisfied that TransGrid has carried out the appropriate work to mitigate the risk of a similar incident occurring in the future.

AEMO correctly applied the criteria published in section 11 of its Power System Security Guidelines<sup>1</sup> in assessing that the circumstances of this incident warranted reclassifying similar incidents as a credible contingency event. AEMO cancelled this reclassification after advice from TransGrid that the cause of the incident was rectified.

## **8 Recommendations**

There is no recommendation arising from this incident.

---

<sup>1</sup> The AEMO operating procedure SO\_OP 3715 Power System Security Guidelines is available at:  
<http://www.aemo.com.au/electricityops/3715.html>