

LED ROADWAY LIGHTING

Inspire Series T20A

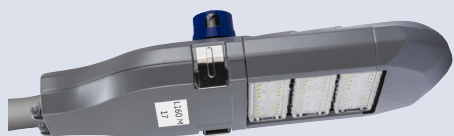

The Inspire series LED Roadway Luminaire is optimised for customers requiring a LED solution to replace traditional 100W HPS fixtures. GE's unique excellent optics are designed to optimise application efficiency and minimize glare. The modern design incorporates the heat sink directly into the unit for heat transfer to prolong LED life. This reliable unit has a 100,000 hours design life, significantly reducing maintenance needs and expense over the life of the fixture. This efficient solution lowers energy consumption compared to traditional HID/HPS fixtures for additional operating cost savings.



Applications

- Designed to meet recommended luminance and illuminance requirements for minor and major roadway/street classification

Electrical

- System wattage 50W (other wattages upon request)
- IP65 control gear chamber
- Input voltage 120-277 VAC
- System power factor is >90%
- Surge Protection 10kV, 5kA

Controls

- 7-pin NEMA socket prewired for dimming and digital & analogue sensor inputs to ANSI C13641(feature enabled for smart city applications)
- 0-10V or DALI dimmable

LED & Optical Assembly

- Flexible combinations of LED modules, light engine designed to optimise application efficiency and minimise glare
- Optical Chamber independently sealed to IP68
- CCT 4000K standard – 3000K and custom optics available upon request
- Upward Light Output Ratio (ULOR) = 0

Housing

- Modular design, air convection effect, advanced thermal management systems
- Die cast and extruded aluminum housing

Finish

- Corrosion resistant polyester powder coated,
- Standard colour is Silver Grey, with Black and special RAL colours available on request

Mounting

- Horizontal mounting position with 42mm-60mm spigot side entry
- Slip fitter with +/- 5 degree of adjustment for leveling

Standards & Environment

- EMC compliant to AS/NZS CISPR
- Complies with technical specification SA/SNZ TS 11586:2015 – luminaire performance
- Meets 3G vibration per ANSI C13631-2010
- Compliant with RoHS – Restriction of Hazardous Substances Directive (EU) 2017/2102
- Ambient operating temperature -40 to 50 Degrees Celsius

LED ROADWAY LIGHTING

Inspire Series T20A

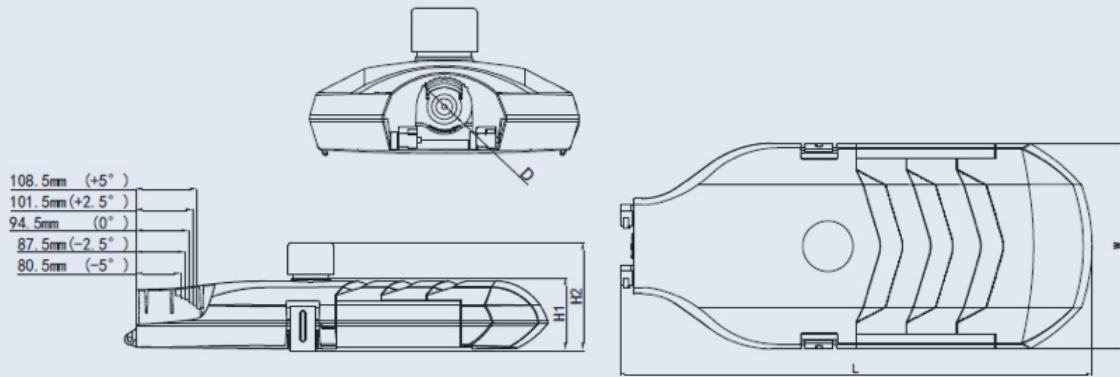

	1 Module
L	670mm
W	325mm
H1	120mm
H2	180mm
D	Ø42-Ø60mm

Model	Net Weight (Kg)	Effective Project Area (m ²)
IRT20A-1Module	8.0	0.218

SKU	Model Number	LED Module Qty	Lumens	System Power	Optical distribution	CCT	Dimming	Housing color
S12846R	IRT20A150M2V340VGR	1	6049	50	M2V3	4000	V	GR

*SKU details for additional product variably can be supplied on request