

OPERATION OF WEST COAST POWER SYSTEM IN TASMANIA ON 13/JUNE/2009

PREPARED BY: ESOPP

FINAL

Table of Contents

1.	INTRODUCTION	3
2.	SUMMARY OF EVENTS	3
3.	NON-MARKET ANCILLARY SERVICES TOOL (NMAS)	4
4.	ANALYSIS OF THE INCIDENT	4
5.	IMMEDIATE ACTIONS	12
6.	POWER SYSTEM SECURITY ASSESSMENT	12
7.	FOLLOW-UP ACTIONS	12
8.	CONCLUSION	13
9.	RECOMMENDATIONS	13
10.	APPENDIX 1	14

1. INTRODUCTION

At 08:08 hours on 13 June 2009, during switching preparation for a planned outage of Farrell to Sheffield No.1 220kV line, the line voltage at Farrell switchyard began a rapid decline. Switching was performed to restore the voltage within the limits. Shortly after the voltage returned within the limits, Bastyan generating unit tripped with a loss of 38 MW of generation.

This report has been prepared under clause 4.8.15 of the Rules to assess the adequacy of the provision and response of facilities & services and the appropriateness of actions taken to restore or maintain power system security.

Information for this report has been supplied to AEMO by Transend and Hydro Tasmania. Data from AEMO's Energy Management System has also been used in analysing the event.

All references to time in this report refer to Market time (Australian Eastern Standard Time).

2. SUMMARY OF EVENTS

This event took place on 13 June 2009 when Transend operators were preparing for the planned outage of Farrell to Sheffield No.1 220kV line.

Switching was required to split and rearrange the network configuration at Farrell 220kV switchyard by opening the 220kV bus coupler circuit breaker A752B before removing the Farrell to Sheffield No.1 220kV line from service.

On the operation of coupler circuit breaker it was observed that voltage on Farrell 220kV B busbar and 110kV busbars deteriorated. Transend operators reclosed the coupler circuit breaker A752B to arrest this fall. This resulted in an increase in voltage on the Farrell 220kV B bus, which was detected by the Automatic Voltage Regulator (AVR) of Bastyan generating unit. The voltage regulator reduced the output of reactive power from the unit.

This resulted in Bastyan generating unit operating in an under-excited state and the unit under-excitation protection system operated to trip the generating unit.

3. NON-MARKET ANCILLARY SERVICES TOOL (NMAS)

Hydro Tasmania uses a reactive power distribution scheme called Non-Market Ancillary Services (NMAS) tool. The NMAS tool distributes the required reactive power support across a number of selected machines within a group based on the actual reactive power output of the group of machines. Before this scheme was introduced the generation controller had to individually set the MVAR output on each machine.

The NMAS tool is designed to operate when the Tasmanian power system is intact and is not capable of managing reactive power requirements when special system rearrangements are in place.

The NMAS system requires the generation controller to enter the value of change in reactive power output required for a group of machines. This change is equally distributed across a number of generating units enabled within a group subject to reactive power limits of individual machines. The generation controller can enable or disable generating units from NMAS scheme at any time. The NMAS scheme does not refer back to any system voltage reference points and is thus not a voltage control scheme.

4. ANALYSIS OF THE INCIDENT

The transmission network configuration including the status of circuit breakers prior to the event is shown in figure 1.

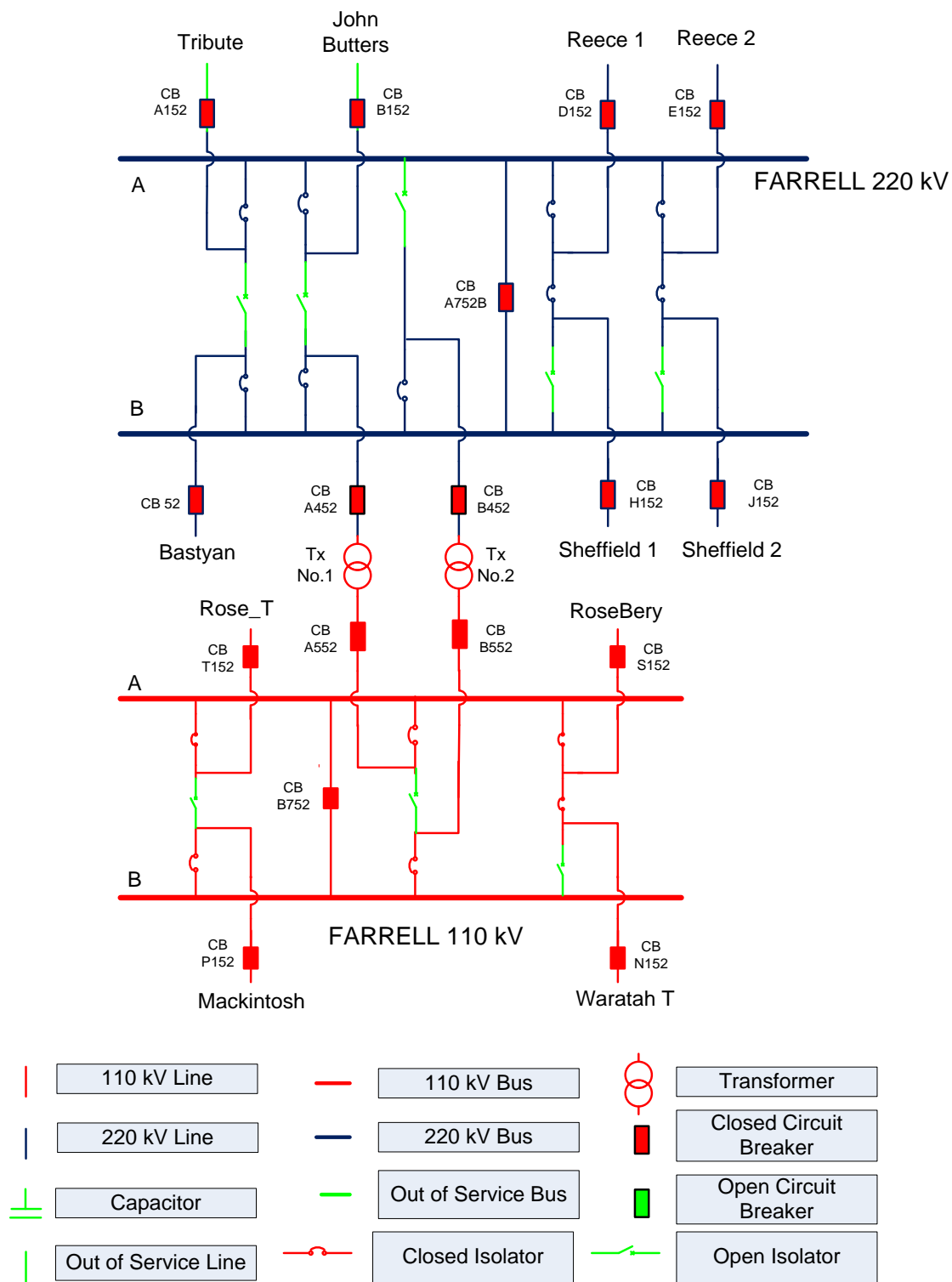

Figure 1 – Single line diagram and status of circuit breakers prior to the event.

In preparation for the planned outage of Farrell to Sheffield No.1 220kV line, switching was performed at Farrell 220kV switchyard to configure the network as follows:

- Farrell to Bastyan 220kV transmission line, 220/110kV Transformer No. 1 and No. 2 were connected to 220 kV 'B' Bus. The 110kV network at Farrell was connected to Burnie via the Hampshire link¹. This arrangement resulted in Bastyan and Mackintosh power stations supplying the West coast load.
- Farrell to Tribute², Farrell to John Butters², Farrell to Reece 1, Farrell to Reece 2 and Sheffield to Farrell No. 1 & 2 220kV lines were connected to 220 kV 'A' Bus. This resulted in Tribute², John Butters², Reece 1 and Reece 2 power stations supplying the Sheffield to Farrell No. 1 & 2 lines.
- At 08:02 hours circuit breaker A752B was opened. This split the 220kV 'A' and 'B' Buses.

Prior to the opening of circuit breaker A752B West coast machines including Bastyan, Mackintosh, Reece 1 and Reece 2 power stations were absorbing reactive power from the system, to prevent high voltage at Farrell switchyard.

The transmission network configuration including the status of circuit breakers after the switching was performed at Farrell 220kV switchyard is shown in figure 2.

¹ Please refer Appendix 1 for the single line diagram showing connections between the Farrell and Burnie switchyards.

² Farrell to Tribute and Farrell to John Butters 220kV transmission lines were open at both ends as Tribute and John Butters units were not online.

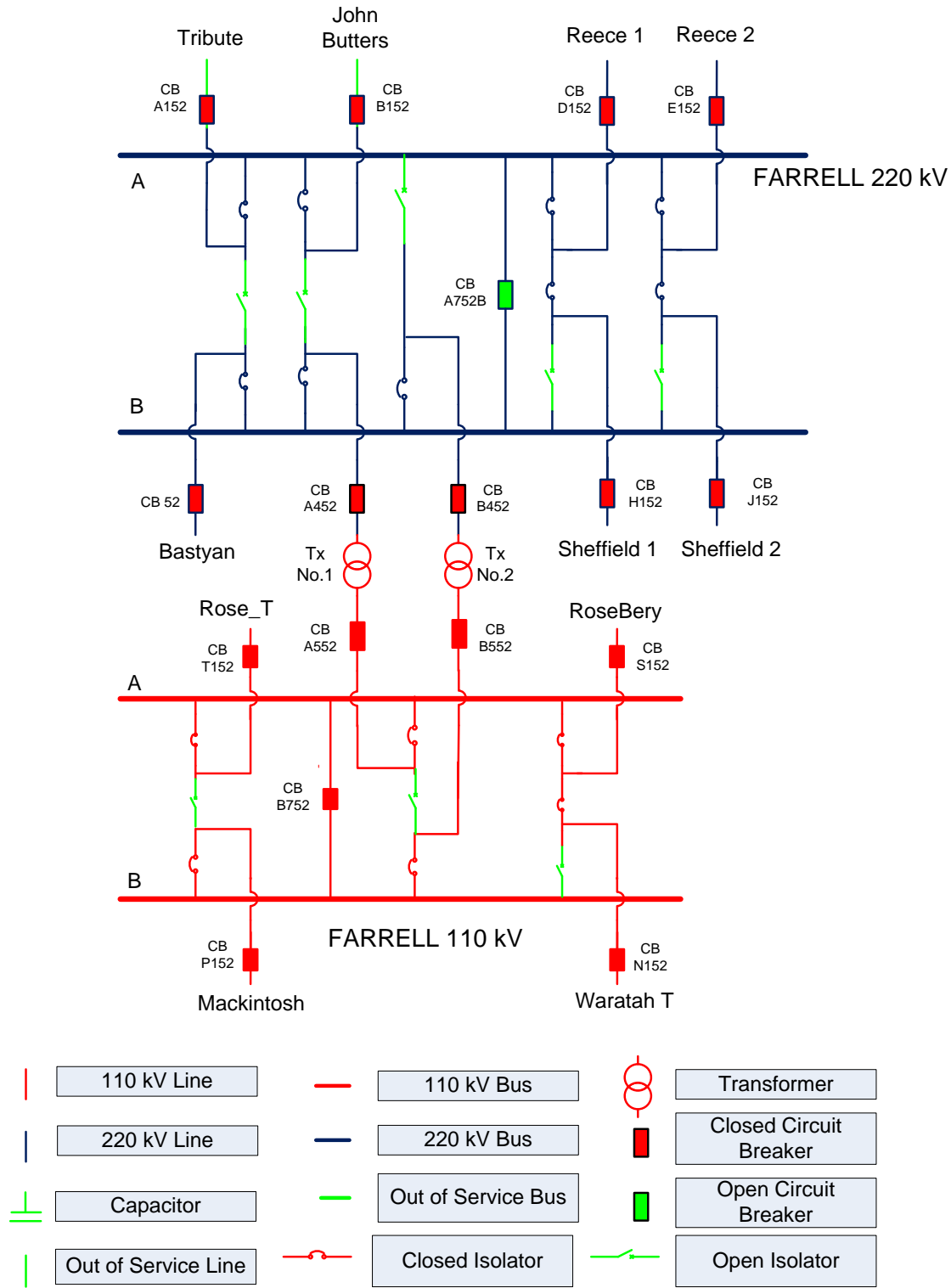

Figure 2 – Single line diagram and status of circuit breakers after the switching.

On the operation of coupler circuit breaker A752B, 220kV 'B' busbar voltage at Farrell switchyard deteriorated to 210kV. Hydro Tasmania and Transend took immediate action to arrest this fall of voltage at Farrell switchyard. The Automatic Voltage Regulator (AVR) of Bastyan and Mackintosh units increased their reactive power outputs in an attempt to maintain the 220kV B bus and 110kV voltages at Farrell switchyard within nominal ratings.

At the time of this incident, Bastyan, Mackintosh, Reece 1 and Reece 2 power stations were operating under reactive power distribution scheme i.e. NMAS tool.

While the AVRs of Bastyan and Mackintosh units increased their reactive power outputs the generation controller further increased the reactive power using the NMAS tool in an attempt to support the voltage at Farrell 220kV 'B' bus.

At 08:06 hours the mode of operation of Mackintosh power station was changed to synchronous condenser by Hydro Tasmania's generation controller. This change in mode was performed to provide contingent voltage support while Bastyan power station supplies the entire West coast load.

Hydro Tasmania's NMAS scheme detected this change and as per its design re-distributed the reactive power output of machines within the group. When a change in mode of operation occurs from generation to synchronous condenser or vice versa the NMAS scheme initiates two control cycles: first re-distribution occurs when the unit comes out of generation mode and the other re-distribution occurs when the unit enters a synchronous condenser mode. This resulted in decreasing the amount of reactive power being absorbed by Reece 1 and Reece 2 power stations and decreasing the amount of reactive power being generated by Bastyan and Mackintosh power stations as these machines were enabled in the same group. This decrease in reactive power output by Bastyan and Mackintosh power stations caused the voltage at Farrell 220kV 'B' Bus to fall.

As the voltages at Farrell 220 kV 'B' Bus and 110kV switchyard fell to 187 kV and 104 kV respectively by 08:08 hours, the coupler circuit breaker A752B was re-closed. The minimum voltage for a satisfactory operation at Farrell switchyard is 198 kV and 99 kV on 220 kV and 110 kV network respectively. Prior to the closure of coupler circuit breaker the west coast power system was in an unsatisfactory state for 60 seconds.

At 08:09 hours the voltages were restored at Farrell 220 kV 'B' Bus and 110kV switchyard to 224kV and 119kV respectively.

Immediately prior to closure of the coupler circuit breaker the voltage at 220kV 'A' bus was 40kV higher than the 220kV 'B' bus. As the Bastyan unit was connected to 220kV 'B' bus, Bastyan AVR detected an increase in voltage thus reducing the reactive power output from the unit. This low excitation was picked up by the under excitation protection system and tripped the Bastyan unit at 08:09 hours.

The 220kV and 110kV voltage profile at Farrell switchyard and the reactive power output of Bastyan and Mackintosh units were as shown in figure 3 and figure 4 respectively.

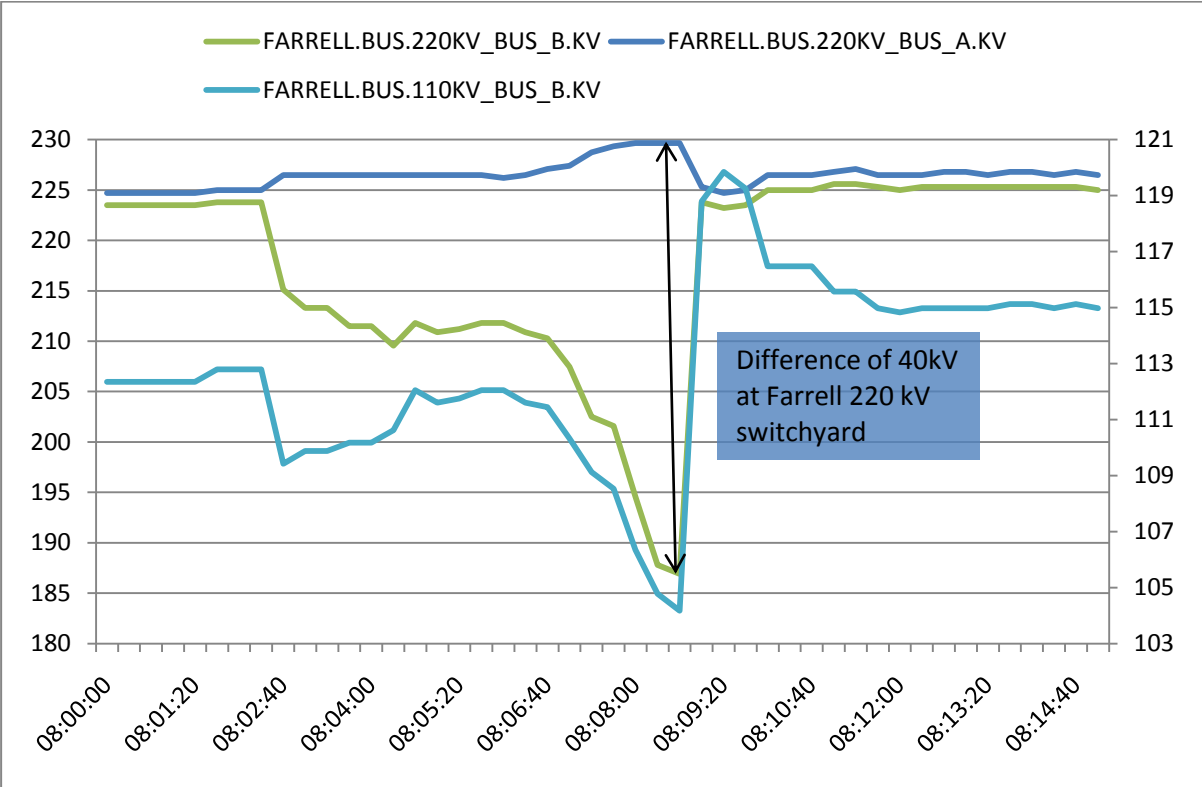

Figure 3 – Voltage profile at Farrell switchyard.

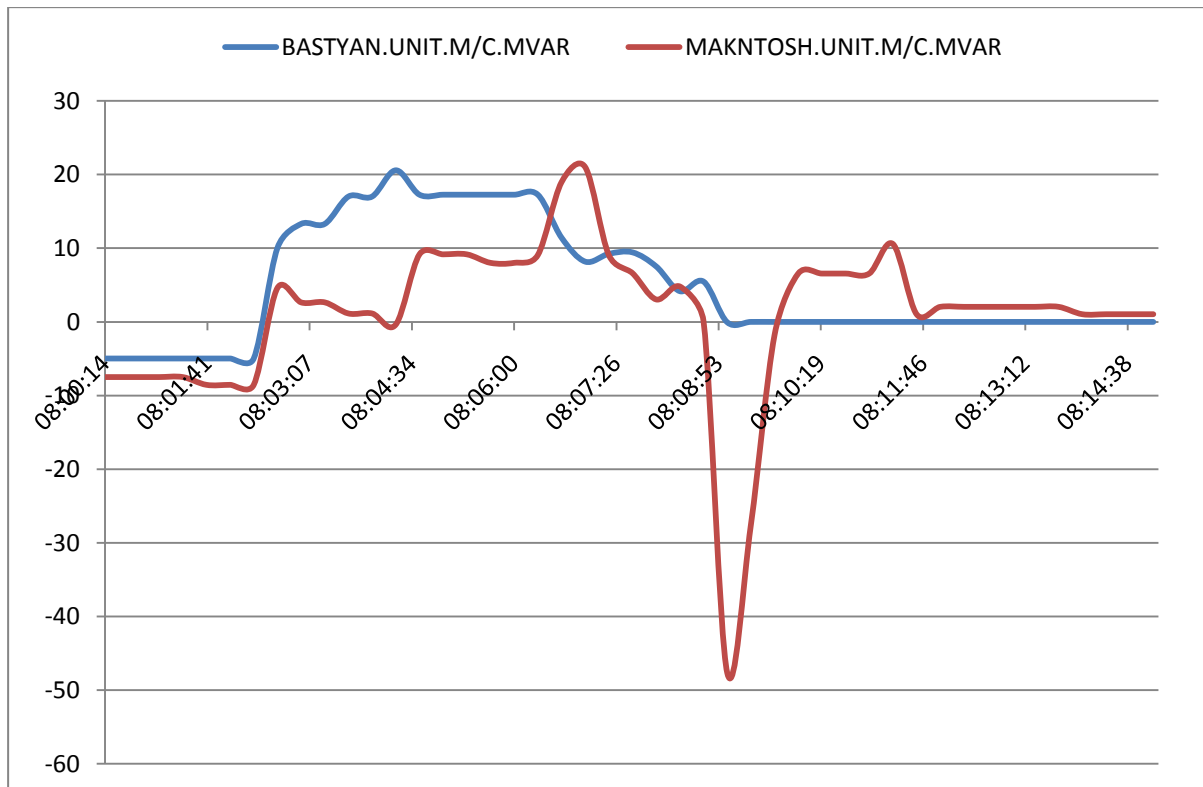

Figure 4 – Reactive power output of Bastyan and Mackintosh units³.

To avoid rapid voltage decline similar to the one experienced on this day in west coast of Tasmania, AEMO recommends that prior to the opening of coupler circuit breaker A752B it is made a normal practice at Farrell switchyard to change the operating mode of one of the west coast units (preferably Mackintosh unit, to provide contingent voltage support for the west coast load) to synchronous condenser.

This provision would require co-ordination between Transend, Hydro Tasmania and AEMO to maintain power system security within the technical envelope.

The transmission network configuration including the status of circuit breakers after the event is shown in figure 5.

³ As the resolution of data used in figure 4 is 4 seconds, the reactive power absorption by Bastyan generating unit at the time of trip was not captured in the graph.

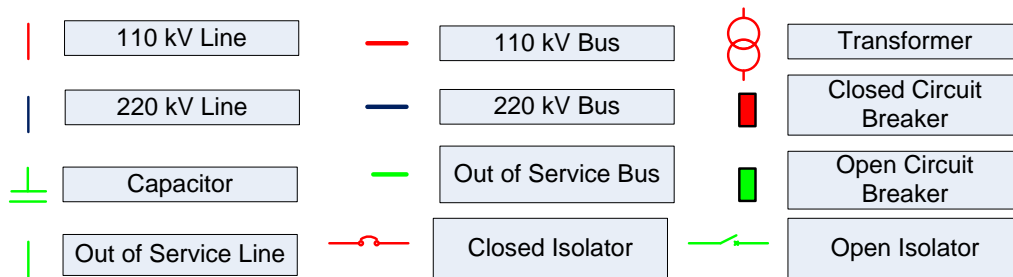
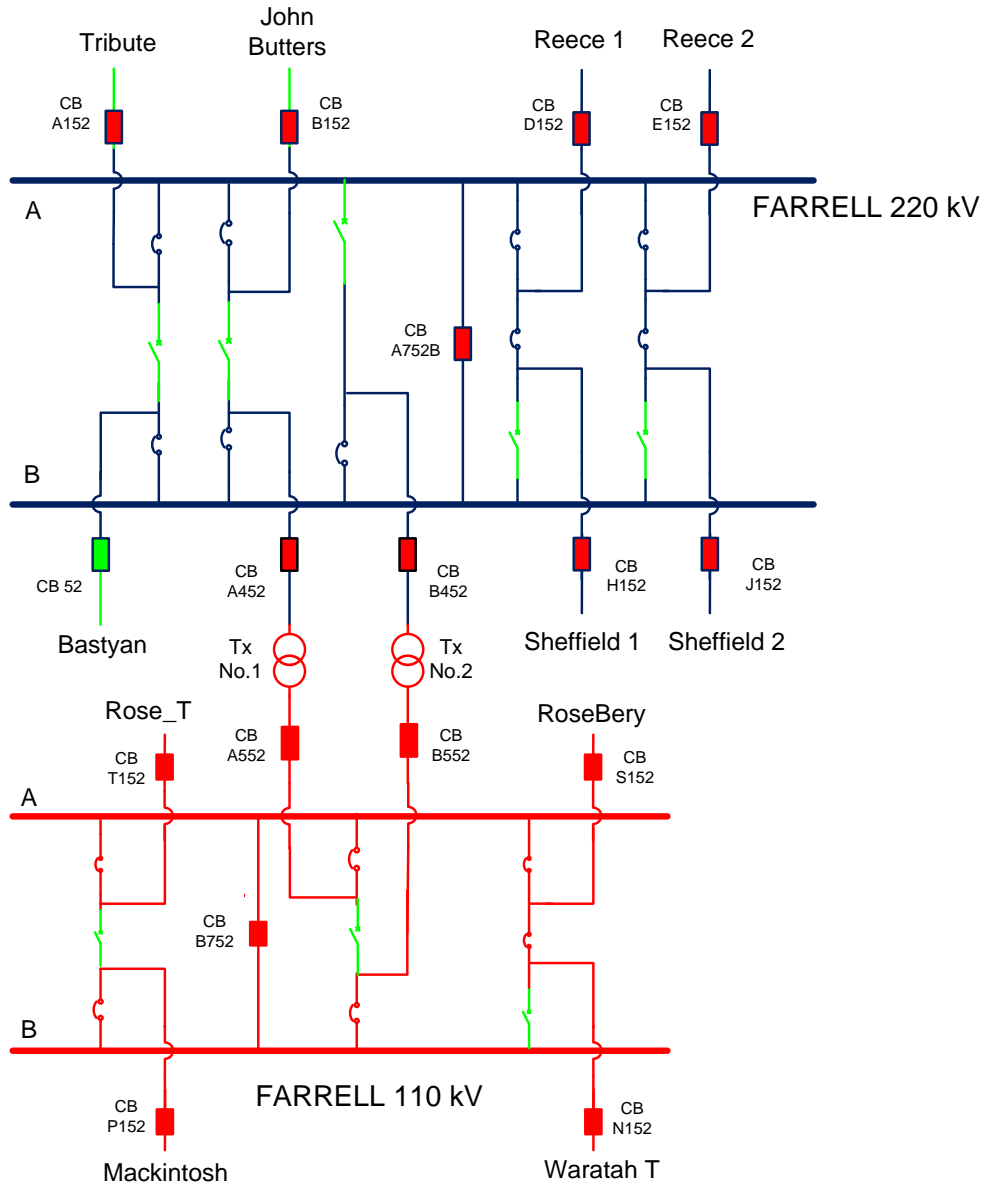

Figure 5 – Single line diagram and status of circuit breakers after the event.

5. IMMEDIATE ACTIONS

Immediately following the trip of Bastyan unit:

- The planned outage of the Farrell to Sheffield No.1 220kV Line was re-scheduled to commence at 09:35 hrs, with Bastyan and Mackintosh generating units disabled from the reactive power distribution scheme – NMAS tool.
- The AEMO control room revoked constraint sets T-FASH_1_2_C & F-T-FASH_1_2_C at 08:35 hours.

6. POWER SYSTEM SECURITY ASSESSMENT

During this incident, the system frequency remained within the frequency operating standard. The voltage at Farrell 220 kV 'B' bus was lower than the acceptable limit which resulted in an unsatisfactory state.

Transmission line, interconnector flows and voltages at Farrell 110 kV switchyard remained within limits during and after the event. Further investigation shows that there were no binding or violating constraints associated with the outages that took place during this incident.

7. FOLLOW-UP ACTIONS

Hydro Tasmania provided a detailed design on the NMAS tool to AEMO and Transend in August 2009.

Hydro Tasmania and Transend have agreed on an operational practice whereby Hydro Tasmania will remove generators from the NMAS scheme upon request when a potential impact on power system security has been identified during the assessment of a network outage.

Hydro Tasmania has modified the NMAS program to avoid triggering a reactive power re-distribution in case of a change in mode of operation of a machine from generation to synchronous condenser or vice versa.

Transend has reminded their power system co-ordinators to keep AEMO informed of changes in the network so that Tasmanian voltages can be maintained within an acceptable range during such events.

Hydro Tasmania have investigated the performance of Bastyan Power Station and concluded that it was compliant with its generator performance standard obligations.

8. CONCLUSION

The decline in voltage at Farrell switchyard was a result of change in operating mode of Mackintosh power station initiated by Hydro Tasmania operations.

The operation of Bastyan generating unit was consistent with the agreed generator performance standards.

Hydro Tasmania staff have agreed that in future for any network outages that may cause a group of generating units to be split, the generating units affected will be removed from their NMAS scheme.

9. RECOMMENDATIONS

Transend update their outage management procedure by end of November 2009 to take into account the potential impacts of the operation of the NMAS tool on power system security due to network outages.

10. APPENDIX 1

The single line diagram of the transmission network connecting Farrell switchyard to Burnie switchyard via the Hampshire – Burnie 110 kV transmission line is shown in figure 5.

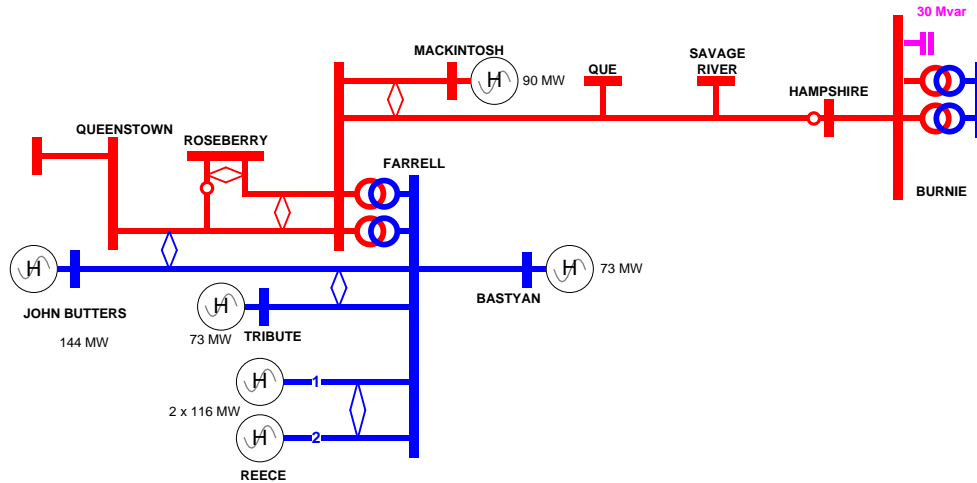

Figure 5 – Single line diagram of the transmission network along the Western corridor of Tasmania.