

TRIP OF LOWER TUMUT - UPPER TUMUT 64 330 KV LINE AND CANBERRA - LOWER TUMUT 7 330 KV LINE ON 11 JULY 2015

AN AEMO POWER SYSTEM OPERATING INCIDENT REPORT
FOR THE NATIONAL ELECTRICITY MARKET

Published: **September 2015**





VERSION RELEASE HISTORY

VERSION	DATE	BY	CHANGES	CHECKED BY	AUTHORISED BY
1	4 Aug 2015	M Ting	Final	J Lu	P Biddle

INCIDENT CLASSIFICATIONS

Time and date of incident	1719 hrs Saturday 11 July 2015
Region of incident	NSW
Affected regions	NSW
Event type	TT – Loss of Multiple Transmission Elements
Generation Impact	No generator was disconnected or limited as a result of this incident
Customer Load Impact	No customer load was disconnected as a result of this incident
Associated reports	Nil

ABBREVIATIONS

Abbreviation	Term
AEMO	Australian Energy Market Operator
CB	Circuit Breaker
kV	Kilovolt
MW	Megawatt
NER	National Electricity Rules



IMPORTANT NOTICE

Purpose

AEMO has prepared this document to provide information about this particular Power System Operating Incident.

Disclaimer

This document or the information in it may be subsequently updated or amended. This document does not constitute legal or business advice, and should not be relied on as a substitute for obtaining detailed advice about the National Electricity Law, the National Electricity Rules, or any other applicable laws, procedures or policies. AEMO has made every effort to ensure the quality of the information in this document but cannot guarantee its accuracy or completeness.

Accordingly, to the maximum extent permitted by law, AEMO and its officers, employees and consultants involved in the preparation of this document:

- make no representation or warranty, express or implied, as to the currency, accuracy, reliability or completeness of the information in this document; and
- are not liable (whether by reason of negligence or otherwise) for any statements or representations in this document, or any omissions from it, or for any use or reliance on the information in it.

Copyright 2014. Australian Energy Market Operator Limited. The material in this publication may be used in accordance with the copyright permissions on AEMO's website.



1. OVERVIEW

This report reviews a power system operating incident on 11 July 2015 in New South Wales. This incident involved the simultaneous trip of two 330 kV transmission lines and was initiated by lightning. No customer load was disconnected as a result of this incident.

The power system is operated such that it will remain in a satisfactory¹ operating state for the loss of single elements in the transmission network. Such events are defined as credible contingency² events. AEMO considers the occurrence of these events to be reasonably possible and will ensure contingency plans are in place to minimise the impact on the power system following a credible contingency event. A non-credible contingency event is a contingency event other than a credible contingency event.

AEMO is required to assess power system security over the course of this incident as the incident is classified as a non-credible contingency under the National Electricity Rules (NER)³. Specifically, AEMO is required to assess the adequacy of the provision and response of facilities and services and the appropriateness of actions taken to restore or maintain power system security⁴.

AEMO concluded that:

1. Lower Tumut-Upper Tumut 330 kV line (Line 64) tripped due to lightning strikes.
2. Canberra-Lower Tumut 330 kV line (Line 07) tripped due to incorrect protection operation.
3. Power system security was maintained over the course of the incident.

This report is based on information provided by TransGrid⁵ and AEMO. National Electricity Market time (Australian Eastern Standard Time) is used in this report.

2. THE INCIDENT

On Monday 11 July 2015 at 1719 hrs, during a lightning storm, Line 64 tripped. Circuit breaker (CB) 642B at Lower Tumut, and, CB 642 at Upper Tumut auto reclosed successfully to restore Line 64 to service. Simultaneously, Line 07 tripped at the Canberra end and remained out of service. Line 64 correctly tripped due to a line fault caused by lightning. Line 07 incorrectly tripped due to the incorrect operation of line protection.

No load or generation was lost as a result of this incident. See Appendix A for a power system diagram illustrating the incident and Appendix B for a chronological log of the incident.

The reason for investigating this incident is that Line 07 incorrectly tripped due to a fault on Line 64. Generally transmission lines should remain in service when there are faults on other transmission lines. The simultaneous tripping of two transmission lines is an unexpected event and is considered as a non-credible contingency.

¹ Refer to NER 4.2.2

² Refer to NER 4.2.3

³ Clause 4.8.15(a)(1)(i) and AEMC Reliability Panel Guidelines for Identifying Reviewable Operating Incidents

⁴ NER Clause 4.8.15 (b)

⁵ TransGrid is the Transmission Network Service Provider in the NSW region



3. TRANSGRID INVESTIGATION

TransGrid investigated this incident and found Line 07 incorrectly tripped on zone 3 line protection at the Canberra end. This was due to an incorrect timer setting causing zone 3 line protection to operate instantaneously. TransGrid corrected the timer issue approximately three hours after the incident.

4. POWER SYSTEM SECURITY

At 1724 hrs, five minutes after the trip, TransGrid closed circuit breakers 072A and 072B at Canberra to return Line 07 to service. The constraints to manage power system security while Line 07 out of service were not invoked as the line was returned to service within five minutes. The power system was in a secure operating state⁶.

At this time, TransGrid advised AEMO that the reason line 07 tripped at Canberra had not been identified.

At 1748 hrs, AEMO issued a Market Notice about 30 minutes after the incident to notify the market of a non-credible contingency event⁷.

AEMO assessed whether or not to reclassify the event as a credible contingency⁸. AEMO was not satisfied that the cause had been identified and considered the incident may reoccur. AEMO thereby reclassified the incident as a credible contingency and issued Market Notice 49292 at 1812 hrs to notify the market.

At 2029 hrs, TransGrid advised AEMO that the reason for line 07 tripping at Canberra had been identified and resolved. AEMO cancelled the reclassification and issued Market Notice 49294 at 2054 hrs to notify the market.

For this incident AEMO correctly assessed the incident and reclassified the incident as a credible contingency, and appropriate notifications were issued.

5. CONCLUSIONS

AEMO concluded that:

1. Line 07 tripped at the Canberra end due to an incorrect protection setting. TransGrid has rectified this protection issue.
2. The provision and response of facilities and services were appropriate and power system security was maintained over the course of the incident.
3. There are no outstanding issues to resolve as a result of this incident.

⁶ AEMO is required to return the power system to a secure state within thirty minutes following a contingency event - NER Clause 4.2.6 (b)

⁷ AEMO is required to notify the Market of a non-credible contingency event within two hours of the event - AEMO, *Power System Security Guidelines*, Section 10.3

⁸ AEMO is required to assess whether or not to reclassify a non credible contingency event as a credible contingency - NER Clause 4.2.3A (c) - and to report how re-classification criteria were applied - NER Clause 4.8.15 (ca). AEMO has to determine if the condition that caused the non-credible contingency event has been resolved.

APPENDIX A. – POWER SYSTEM DIAGRAM

The power system during the incident – circuit breakers on Line 64 opened, and circuit breakers on Line 07 opened at Canberra end only.

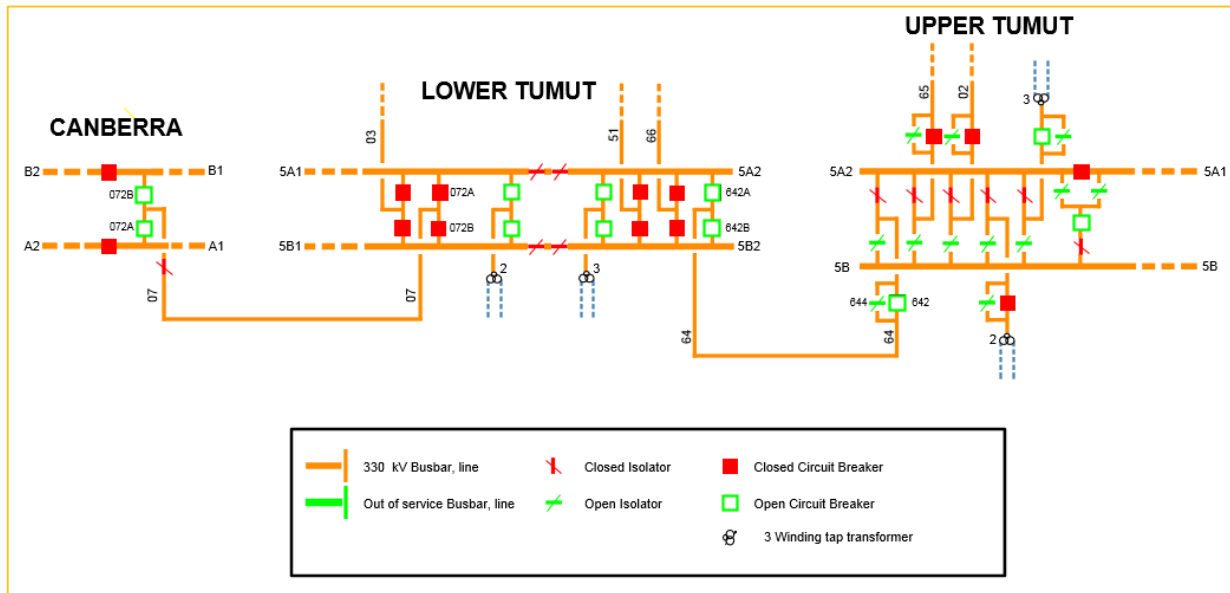

APPENDIX B. – INCIDENT EVENT LOG

Table 1 Incident Log

Time and Date	Event
1719 hrs 11 July 2015	Lower Tumut-Upper Tumut 64 330 kV line tripped and auto reclosed via CBs: <ul style="list-style-type: none"> 642B at Lower Tumut 642 at Upper Tumut
1719 hrs 11 July 2015	Canberra-Lower Tumut 07 330 kV line opened at Canberra end only
1720 hrs 11 July 2015	TransGrid returned CB 642A at Upper Tumut back to service
1724 hrs 11 July 2015	TransGrid returned Canberra-Lower Tumut 07 330 kV line back to service
1748 hrs 11 July 2015	AEMO issued Market Notice 49291 to notify the market of the non-credible contingency event
1812 hrs 11 July 2015	AEMO issued Market Notice 49292 to notify the reclassification of non-credible contingency event to a credible contingency event
1909 hrs 11 July 2015	TransGrid advised the following: <ul style="list-style-type: none"> All 3 phases tripped on Lower Tumut-Upper Tumut 64 330 kV line The protection relay at Canberra operated incorrectly and the cause could not be identified
2029 hrs 11 July 2015	TransGrid advised that the protection relay at Canberra had been resolved and the incident was unlikely to occur again
2054 hrs 11 July 2015	AEMO issued Market Notice 49294 to cancel the reclassification