Total Transmission Cost Estimate for the Maximum Reserve Capacity Price for 2018/19

Date: 19 October 2015

Prepared by: Regulation and Investment Management



Contents

1. Introduction	2
1.1 Revised Total Transmission Cost Estimate	2
2. Methodology	3
2.1 Western Power’s Contributions Policy and NFIT	3
3. Shallow Connection Costs	5
3.1.1 Substation	5
3.1.2 Overhead Line to Power Station	6
3.1.3 Easement for Overhead Line	6
3.1.4 Total Shallow Connection Cost	6
4. Results	7
4.1 Total Transmission Costs	7
4.2 Escalation Factor for Network Infrastructure	7
Appendix A. Auditor’s Report	8

1. Introduction

This document provides the calculation of the Transmission Connection Costs in accordance with section 2.4 of the Independent Market Operator's Market Procedure: Maximum Reserve Capacity Price, Version 6.

Section 2.4.1 of the market procedure requires Western Power to use capital contributions from relevant users to calculate an estimate of Transmission Connection Costs. It should be noted that Western Power is obligated under relevant legislation to treat commercially sensitive customer information on a confidential basis. Individual customer capital contributions which are now required to be used to calculate the Transmission Connection Costs can't be publically disclosed by Western Power. The market procedure recognises this, and consequently requires that Western Power appoint a suitable auditor to review the application of the process in step 2.4.1 on a confidential and independent basis. The Auditor's Report is included as Appendix A.

Section 2.4.2 of the market procedure requires Western Power to estimate shallow connection costs to be included in the Transmission Connection Costs where relevant capital contribution data is not available and also to calculate an average percentage escalation for electricity infrastructure assets for use by the IMO elsewhere in the market procedure.

The IMO has requested Western Power to use a spreadsheet which they have provided and has been verified by the IMOs' auditor to implement the requirements of the market procedure. Western Power has collated customer capital contributions and shallow connection costs and included them in the spreadsheet provided by the IMO. The results are presented in this report.

1.1 Revised Total Transmission Cost Estimate

Following completion and auditing of a previous version of this report, the IMO advised Western Power of an error in the calculation for easement costs used in the Transmission Cost estimate. This error changed the outcome of the Transmission Cost estimate. This version of the report replaces the original report dated 25 September 2015.

The following amendments have been processed and incorporated into this revised report:

Original easement cost estimate for overhead line: \$5,093,757

Revised easement cost estimate for overhead line: \$5,112,812

These changes have led to the following changes in the Total Transmission Cost:

Original Total Transmission Cost: \$160,161

Revised Total Transmission Cost: \$160,280

2. Methodology

In accordance with the IMO market procedure, Western Power must provide an estimate of the Transmission Connection Costs using the methodology specified.

In summary, the estimated Transmission Connection Cost is based on a weighted average over 5 years of the capital contributions (either paid historically or expected to be paid to Western Power under Access Offers and Western Power's Contribution Policy as approved by the ERA) only for generators that are capable of being gas or liquid fuelled.

The calculation must exclude any facility where:

- the significant driver for the location of the facility is the access to source energy (fuel or renewable) or the need to embed the generation with a load (electrical or heat); or
- the facility is connected on a shared distribution feeder; or
- the capital contribution does not relate to a significant increase in the Declared Sent Out Capacity associated with the facility.

Where no capital contributions have been paid in a particular year an estimate of shallow transmission connection costs only for the works required to connect a relevant generator to the shared transmission is used.

Western Power must estimate the shallow transmission connection costs for the works required to connect a relevant generator to the shared transmission network in accordance with section 2.4.2 of the procedure.

The estimate of shallow connection costs is also used to determine the basis of escalation of network infrastructure costs where relevant, and it is calculated as an average change over 5 years in the estimates calculated consistent with section 2.4.2.

For more details of methodology, please see the market procedure on the IMO web site:

http://imowa.com.au/docs/default-source/rules/imo-wem-procedures-and-other-documents/pc_2012__08_final_amended_market_procedure__clean_.pdf

2.1 Western Power's Contributions Policy and NFIT

Actual transmission connection costs are governed by the Access Code 2004, the New Facilities Investment Test (NFIT), and Western Powers' Access Arrangement including the Contributions Policy approved by the ERA.

In accordance with section 5.2 of Western Powers' contributions policy, a contribution payable by a customer for any works is calculated by:

- determining the appropriate portion of any of the *forecast costs* of the *works* which do not meet the *new facilities investment test*,
- adding any applicable costs related to ensuring *technical rules* compliance for the network,
- adding the full *costs* of any *works* to provide *connection assets*, and the full amount of any *non-capital costs* that Western Power incurs acting efficiently in accordance with *good electricity industry practice*,
- acting as a *reasonable and prudent person*, Western Power may determine that the costs be allocated to the applicant and other users based on the relative use of the *works* (in accordance with section 5.4),

- deducting the amount likely to be recovered in the form of *new revenue* gained from providing *covered services* to the *applicant*, as calculated over the reasonable time, at the *contributions rate of return*.

Future capital contributions which may be required from users do not relate to the transmission component of the MRCP. Capital contributions required from new users will be assessed individually and depend on the amount of network investment that may or may not pass NFIT which may ultimately be determined by the ERA.

3. Shallow Connection Costs

For the purposes outlined in step 2.4.1 of the Market Procedure, Western Power must estimate the shallow transmission connection costs for the works required to connect a relevant generator to the shared transmission network.

In summary, estimates in accordance with section 2.4.2 of the procedure are required for the costs for the following:

- a substation,
- 2 km of overhead line to the power station, and
- an overhead line easement.

Each of these cost components are discussed below.

3.1.1 Substation

In accordance with the Market Procedure the Transmission Connection Cost Estimate should include the cost of a generic three breaker mesh substation configured in a breaker and a half arrangement. The connection of the substation into the transmission line should be turn-in, turn-out and will be based on the most economical (i.e. least cost) solution. The typical three-switch mesh 330 kV substation configuration which has been used recently in the SWIS has been assumed as shown in the single line diagram in Figure 1.

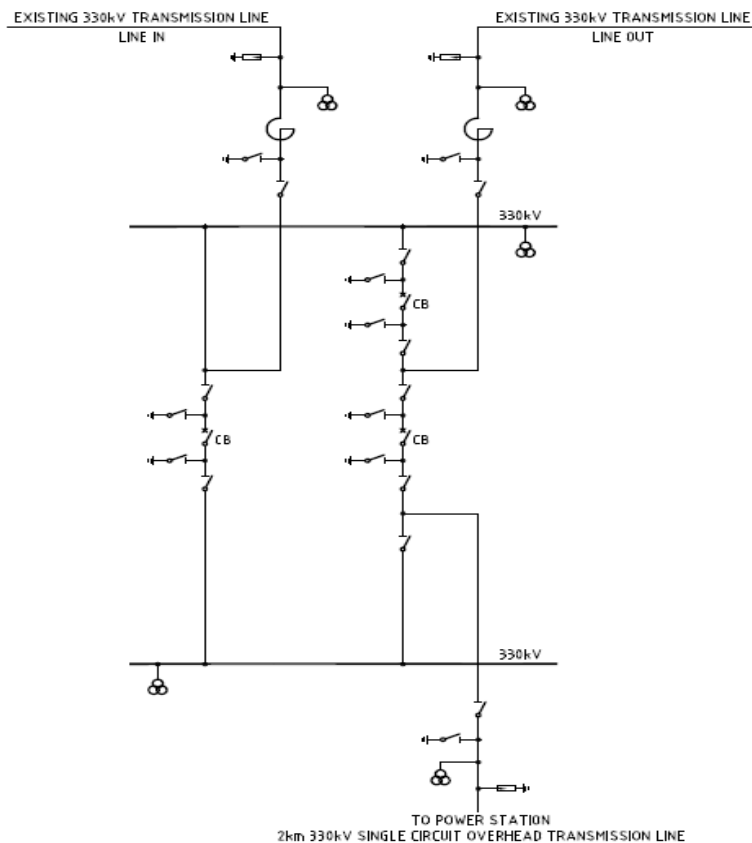

Figure 1

Table 1 lists the estimated costs of a typical new substation. It should be noted that the estimate does not include the cost of the land nor does it take into account any site specific details.

Table 1- Total Substation Cost

Description	Cost
330kV Breaker & Half, 3xCircuit Breakers, 3xGantry, 2xCircuits	\$4,268,000
Site Works - Terminal Station 1 Yard (3 Bays)	\$2,807,000
Terminal Relay Room	\$2,740,000
TOTAL	\$9,815,000

3.1.2 Overhead Line to Power Station

In accordance with the MRCP Procedure the Transmission Connection Cost Estimate should include the cost for 2 km of 330 kV overhead single circuit line to the power station that will have one road crossing. It shall be assumed that the transmission connection to the Power Station will be located on 50% flat - 50% undulating land, 50% rural - 50% urban location and there will be no unforeseen environmental or civil costs associated with the development.

Table 2 shows the estimated costs of the 2km transmission line connection.

Table 2 - Connection Transmission Line Costs

Description	Cost
Connection Assets (Two kilometres of single circuit steel towers to connect the generator)	\$8,056,014

3.1.3 Easement for Overhead Line

In accordance with the MRCP Procedure, the cost of an easement for the 2km overhead line has been provided by the IMO in accordance with section 2.4.2(h) of the procedure and is \$5,112,812.

3.1.4 Total Shallow Connection Cost

The Total Shallow connection costs calculated in accordance with section 2.4.2 of the procedure is shown in Table 3.

Table 3 - Total Transmission Connection Cost Estimate

Description	Cost
Substation	\$9,815,000
Transmission line	\$8,056,014
Line easement	\$5,112,812
TOTAL	\$22,983,826

4. Results

Western Power is required to provide an estimate of the Total Transmission Costs in accordance with section 2.4 of the IMO Market Procedure: Maximum Reserve Capacity Price. In accordance with the procedure, Western Power has sought agreement with the IMO regarding which generators should be included in the calculation of the Transmission Connection Costs, and has collated all relevant information including confidential capital contribution data and estimates of shallow connection costs for the current and previous years. The Transmission Connection Cost has been calculated in accordance with the specified methodology which is summarised in section 2.1 of this report.

4.1 Total Transmission Costs

The Total Transmission Costs calculated in 2015 for the MRCP for 2018/19 in accordance the Market Procedure is \$160,280 / MW. This is a decrease of 0.6% when compared to the previous year's price.

4.2 Escalation Factor for Network Infrastructure

The escalation factor for network infrastructure calculated in accordance with section 2.4.1(d) of the Market Procedure is -2.20%.

Appendix A. Auditor's Report



Ernst & Young
11 Mounts Bay Road
Perth WA 6000 Australia
GPO Box M939 Perth WA 6843

Tel: +61 8 9429 2222
Fax: +61 8 9429 2436
ey.com/au

Independent Assurance Practitioner's Review Report to the Directors of Electricity Networks Corporation

Report on the Total Transmission Cost Estimate for the Maximum Reserve Capacity Price for 2018/19

We have reviewed the process adopted by Electricity Networks Corporation ("Western Power") to estimate the Total Transmission Cost for the Maximum Reserve Capacity Price for 2018/19 as required by the Independent Market Operator's Market Procedure: Maximum Reserve Capacity Price Version 6.

Respective Responsibilities

Management of Western Power are responsible for the preparation of the Total Transmission Cost Estimate for the Maximum Reserve Capacity Price for 2018/19 in accordance with the requirements of the Independent Market Operator's Market Procedure: Maximum Reserve Capacity Price Version 6.

Our responsibility is to express a conclusion on the process adopted by Western Power in determining the Total Transmission Cost for the Maximum Reserve Capacity Price for 2018/19 as required by the Independent Market Operator's Market Procedure: Maximum Reserve Capacity Price Version 6. Our review has been conducted in accordance with Auditing Standard ASAE 3000 *Assurance Engagements other than Audits or Reviews of Historical Financial Information*, to provide limited assurance that Western Power has followed the process to determine the Total Transmission Cost Estimate for the Maximum Reserve Capacity Price for 2018/19 as required by the Independent Market Operator's Market Procedure: Maximum Reserve Capacity Price Version 6. Our procedures consisted of making enquiries of persons responsible for the preparation of the Total Transmission Cost Estimate for the Maximum Reserve Capacity Price for 2018/19 and applying analytical and other review procedures. These procedures have been undertaken to form a conclusion that nothing has come to our attention that causes us to believe that Western Power has not, in all material respects, undertaken a process to determine the Total Transmission Cost Estimate for the Maximum Reserve Capacity Price for 2018/19 that is in accordance with the Independent Market Operator's Market Procedure: Maximum Reserve Capacity Price Version 6.

Use of Report

This review report was prepared for Western Power in accordance with the Independent Market Operator's Market Procedure: Maximum Reserve Capacity Price Version 6. We disclaim any assumption of responsibility for any reliance on this report to any persons or users other than Western Power, or for any purpose other than that for which it was prepared.

Inherent Limitations

Because of the inherent limitations of any process, it is possible that fraud, error or non compliance with a process may occur and not be detected. A review is not designed to detect all instances of non compliance with the requirements of the Independent Market Operator's Market Procedure: Maximum Reserve Capacity Price Version 6 as it generally comprises of making enquiries of persons responsible for the preparation of the Total Transmission Cost Estimate for the Maximum Reserve Capacity Price for 2018/19 and applying analytical and other review procedures. The review conclusion expressed in this report has been formed on the above basis.



Independence

In conducting our review, we have complied with the independence requirements of Australian professional accounting bodies.

Conclusion

Based on our review, which is not an audit, nothing has come to our attention that causes us to believe that Electricity Networks Corporation has not, in all material respects, adopted a process to estimate the Total Transmission Cost for the Maximum Reserve Capacity Price for 2018/19 that is in accordance with the Independent Market Operator's Market Procedure: Maximum Reserve Capacity Price Version 6.

Revision of Total Transmission Cost Estimate for the Maximum Reserve Capacity Price for 2018/19

Without qualification to the Conclusion expressed above, attention is drawn to Note 1.1 in the Report on the Total Transmission Cost Estimate for the Maximum Reserve Capacity Price for 2018/19. For the reasons fully described in that note, the previously issued Report on the Total Transmission Cost Estimate for the Maximum Reserve Capacity Price for 2018/19 has been revised. Accordingly, this review report replaces our review report dated 30 September 2015 in which we originally reported on the Total Transmission Cost Estimate for the Maximum Reserve Capacity Price for 2018/19.

A handwritten signature in black ink, appearing to read 'Ernst & Young', written over a horizontal line.

Ernst & Young

A handwritten signature in black ink, appearing to read 'Robert A Kirkby', written over a horizontal line.

Robert A Kirkby
Partner
Perth
19 October 2015