

# INDEPENDENT PLANNING REVIEW

AUSNET SERVICES ASSET REINVESTMENT PROJECTS

Published: **June 2016**

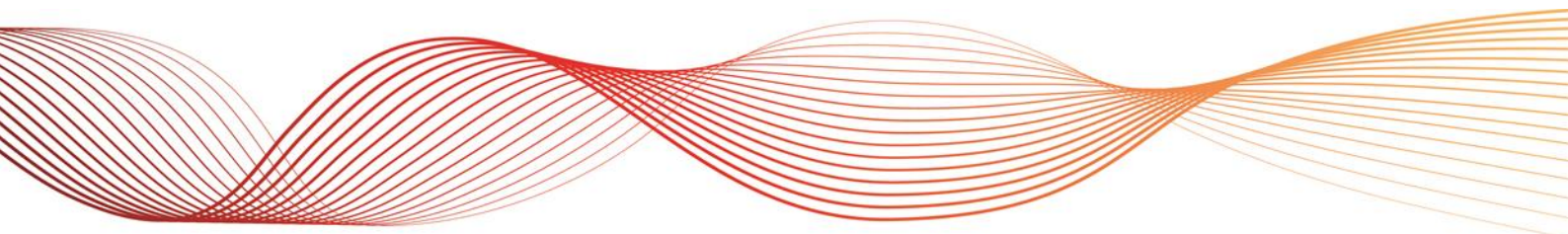



# IMPORTANT NOTICE

## Purpose

The purpose of this publication is to provide information in relation to future development needs for the Victorian transmission network.

AEMO publishes this report in its capacity as National Transmission Planner, exercising the functions set out in section 49(2) of the National Electricity Law. This publication is based on information available to AEMO as at 1 June 2016.

## Disclaimer

AEMO has made every effort to ensure the quality of the information in this publication but cannot guarantee that information, forecasts and assumptions are accurate, complete or appropriate for your circumstances. This publication does not include all of the information that an investor, participant or potential participant in the National Electricity Market might require, and does not amount to a recommendation of any investment.

Anyone proposing to use the information in this publication (including information and reports from third parties) should independently verify and check its accuracy, completeness and suitability for purpose, and obtain independent and specific advice from appropriate experts.

Accordingly, to the maximum extent permitted by law, AEMO and its officers, employees and consultants involved in the preparation of this publication:

- make no representation or warranty, express or implied, as to the currency, accuracy, reliability or completeness of the information in this publication; and
- are not liable (whether by reason of negligence or otherwise) for any statements, opinions, information or other matters contained in or derived from this publication, or any omissions from it, or in respect of a person's use of the information in this publication.

## Acknowledgement

AEMO acknowledges the co-operation and contribution of AusNet Services in providing data and information used in this publication.

## Version control

Version	Release date	Changes
1	9/6/2016	



## EXECUTIVE SUMMARY

This planning review provides an independent, technical assessment of emerging transmission network reinvestment requirements in Victoria over the next 10 years.

AEMO compared AusNet Services' 2015 and 2016 asset renewal plans, and this review focuses on station and line projects that were not included in AusNet Services' 2015 asset renewal plan.

The report is intended to provide input for:

- AusNet Services, Victorian Transmission Network Service Provider (TNSP), in its consideration of future asset investment proposals.
- Non-network service providers, in identifying potential opportunities for non-network development.

AEMO's independent review found that AusNet Services' renewal plan is largely aligned with transmission network needs over the 10-year horizon.

Of the 14 reinvestment projects reviewed by AEMO, AEMO found two possible opportunities to retire the plant without replacements, a possible opportunity for non-network services alternatives for transformer replacement, and a possible opportunity for non-network services to optimise capacity of replacement transformers:

- **Keilor 500/220 kV transformer replacement** – There is an opportunity to retire either the A2 or A3 500/220 kV transformer at Keilor terminal station, subject to a more detailed investigation. AusNet Services estimates that this option could reduce capital expenditure by approximately \$30 million. Following AEMO's review, AusNet Services reduced the number of planned transformer replacements at Keilor Terminal Station from three to two, and reduced the forecast capital expenditure by \$30 million. The final AusNet Service asset renewal plan published with the *2016 Victorian Annual Planning Report (VAPR)* incorporates this change.
- **Thomastown 220/66 kV B4 transformer replacement** – There is an opportunity to retire the 220/66 kV B4 transformer at Thomastown terminal station, based on AEMO's connection point demand forecasts. AEMO estimates that this option could reduce capital expenditure by approximately \$15 million. Ongoing need for this transformer is jointly determined by DNSPs (Jemena and AusNet Electricity Services). AEMO considers it is appropriate for the DNSPs to continuously monitor the demand at Thomastown and identify the most economic option.
- **Keilor 220/66 kV B4 transformer replacement** – Ongoing need exists for replacement of Keilor B4 transformer. There is an opportunity for non-network alternatives for B4 transformer replacement if cost-effective.
- **Kerang 220/66/22 kV 1&2 transformer replacement** – Ongoing need exists for replacement of Kerang 220/66/22 kV 1&2 transformers, and additional transformer capacity may even be required. There is a potential for optimising capacity of new transformers if a non-network solution is cost-effective.



# CONTENTS

<b>EXECUTIVE SUMMARY</b>	<b>3</b>
<b>1. INTRODUCTION</b>	<b>5</b>
<b>2. AEMO'S NATIONAL TRANSMISSION PLANNER ROLE</b>	<b>6</b>
<b>3. AEMO'S REVIEW SCOPE AND METHODOLOGY</b>	<b>7</b>
<b>4. AEMO'S REVIEW OF ASSET REINVESTMENT WORKS</b>	<b>9</b>
<b>5. FINDINGS OF AEMO'S REVIEW</b>	<b>10</b>
<b>APPENDIX A. REVIEW OF AUSNET SERVICES' REINVESTMENT PROJECTS</b>	<b>11</b>
A.1 Substations	11
A.2 Transmission Lines	25
<b>MEASURES AND ABBREVIATIONS</b>	<b>28</b>
Units of measure	28
Abbreviations	28
Victorian terminal and power stations	28
<b>GLOSSARY</b>	<b>31</b>



# 1. INTRODUCTION

This review provides an independent, technical assessment of the emerging transmission network reinvestment requirements in Victoria over the next 10 years identified by AusNet Services. Its purpose is to facilitate efficient, reliable and secure development of the transmission network in consumers' long-term interests.

The review assesses the extent to which proposed reinvestments by AusNet Services are required to address transmission network needs over the next 10 years, and considers whether alternative options could better address these needs.

In undertaking this review, AEMO has compared AusNet Services' 2015 and 2016 asset renewal plans and sought clarification on the changes to last year's plan. The review focuses on station and line projects that were not included in AusNet Services' 2015 asset renewal plan.

The report is intended to provide input for:

- AusNet Services, Victorian Transmission Network Service Provider (TNSP), in its consideration of future asset investment proposals.
- Non-network service providers, in identifying potential opportunities for non-network development.

AEMO engaged with AusNet Services throughout this review process to develop and apply an impartial, transparent, technically-consistent assessment methodology.

AusNet Services' completed asset renewal plan is published with AEMO's *2016 Victorian Annual Planning Report (VAPR)*.<sup>1</sup> The asset renewal plan includes options considered by AusNet Services, and material changes since the plan's previous publication with the 2015 VAPR.

---

<sup>1</sup> 2016 *Ausnet Services Asset Renewal Plan*. Available at: <http://www.aemo.com.au/Electricity/Planning/Victorian-Annual-Planning-Report/VAPR-Supporting-Information>

## 2. AEMO'S NATIONAL TRANSMISSION PLANNER ROLE

AEMO undertook this review as part of its National Transmission Planner (NTP) responsibilities under the National Electricity Law. As part of its NTP function, AEMO must:

- Keep the national transmission grid under review and provide advice on grid development or projects that could affect the grid.<sup>2</sup>
- Provide a national strategic perspective for transmission planning and coordination.<sup>3</sup>
- Have regard to the National Electricity Objective.<sup>4</sup>

AEMO's capacity as National Transmission Planner enables it to provide an independent review of the investment requirements consistently across National Electricity Market (NEM) regions.

This report is one part of an integrated package of AEMO activities that supports efficient transmission investment in the NEM. Other measures include:

- Developing long-term planning outlooks for current and potential national transmission flow paths<sup>5</sup>, published in the annual *National Transmission Network Development Plan* (NTNDP).<sup>6</sup>
- Developing the VAPR, in which AEMO considers the adequacy of the DSN to meet its reliability requirements over the next 10 years, and identifies a range of possible network and non-network investment opportunities to address emerging network constraints.<sup>7</sup>
- Reviewing projects proposed by TNSPs under the AER's network capability incentive scheme<sup>8</sup>, designed to improve use of existing network assets through low-cost projects. TNSPs must consult with AEMO before submitting their Network Capability Incentive Parameter Action Plans (NCIPAPs) to the AER.<sup>9</sup>
- Preparing and publishing independent, consistently-derived operational consumption and maximum demand forecasts for each NEM region in the *National Electricity Forecasting Report* (NEFR).<sup>10</sup>
- Preparing and publishing detailed, local maximum demand forecasts in *Transmission Connection Point Forecasting Reports* for each NEM region.<sup>11</sup>
- Developing and publishing a NEM-wide review of the value of customer reliability – the economic value different users place on a reliable supply of electricity – to help network planners, asset owners, and the AER align future network investment with how much customers are willing to pay for a secure and reliable electricity supply.<sup>12</sup>

<sup>2</sup> National Electricity Law, s49(2)(c).

<sup>3</sup> National Electricity Law, s49(2)(d).

<sup>4</sup> National Electricity Law, s49(3). The National Electricity Objective is set out in s7 of the National Electricity Law. It is "to promote efficient investment in, and efficient operation and use of, electricity services for the long term interests of consumers of electricity with respect to (a) price, quality, safety, reliability and security of supply of electricity; and (b) the reliability, safety and security of the national electricity system".

<sup>5</sup> National transmission flow paths are defined in the Rules as any portion of transmission networks used to transport significant amounts of electricity between generation centres and load centres.

<sup>6</sup> AEMO. *2015 National Transmission Network Development Plan*. Available: <http://www.aemo.com.au/Electricity/Planning/National-Transmission-Network-Development-Plan>.

<sup>7</sup> AEMO. *2016 Victorian Annual Planning Report*. Available: <http://www.aemo.com.au/Electricity/Planning/Victorian-Annual-Planning-Report>.

<sup>8</sup> The Network Capability Incentive Parameter Action Plan (NCIPAP) is designed to support improved usage of existing network assets through low-cost projects.

<sup>9</sup> AER. *Electricity Transmission Network Service Providers Service Target Performance Incentive Scheme*. Version 5. s 5.2(h), page 13. October 2015.

<sup>10</sup> AEMO. *National Electricity Forecasting Report*. Available: <http://www.aemo.com.au/Electricity/Planning/Forecasting/National-Electricity-Forecasting-Report>.

<sup>11</sup> AEMO. *Transmission Connection Point Forecasting*. Available: <http://www.aemo.com.au/Electricity/Planning/Forecasting/AEMO-Transmission-Connection-Point-Forecasting/Transmission-Connection-Point-Forecasting-Report-for-Victoria>.

<sup>12</sup> AEMO. *Value of Customer Reliability review*. Available at <http://www.aemo.com.au/Electricity/Planning/Value-of-Customer-Reliability-review>.

### 3. AEMO’S REVIEW SCOPE AND METHODOLOGY

AEMO has reviewed AusNet Services’ proposed asset renewal projects to assess the ongoing need for these assets, and suggests alternative options in some instances. This review is intended to be an input to any assessment of AusNet’s efficient replacement expenditure but it does not consider all issues relevant to an investment decision. In particular, we have not sought to assess the condition of AusNet’s assets.

This review was based on AEMO’s:

- Assessment methodology developed for consistent application across the NEM.
- Independent forecasts of maximum demand at the transmission connection point level for Victoria.

Figure 1 outlines the methodology that AEMO applies in assessing TNSPs’ asset renewal plans, and used in this review to assess reinvestment works proposed in AusNet Services’ asset renewal plan which AEMO had not previously reviewed.

AEMO’s assessment methodology can be summarised as follows:

1. **Network capability:** Determine the level of generation and/or demand the network could support if the asset was retired. This assessment considers the satisfactory and secure operating states<sup>13</sup> of the power system including efficient configuration of network assets.
2. **Network capability against forecast demand:** Apply the most recent connection point forecast to determine expected load at risk and/or market congestion over the next ten years if the asset was retired.
3. **The network need for the project:**
  - If no expected load at risk or market congestion is identified, conclude that the asset identified for replacement is no longer required.
  - Otherwise, identify potential reinvestment options which would be subject to further investigation and cost-benefit analysis.

**Figure 1 Assessment approach for condition driven investment**

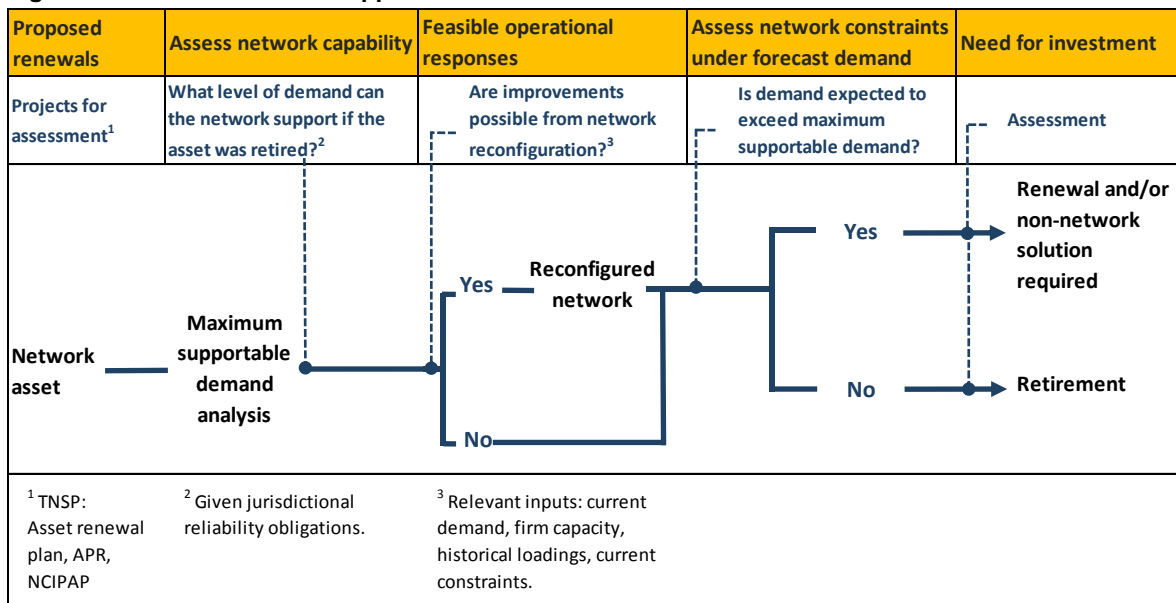

<sup>13</sup> A satisfactory operating state requires (among other requirements listed in Chapter 4 of the National Electricity Rules) all network elements to be loaded within their ratings (accounting for time dependency in the case of emergency ratings). A secure operating state requires the power system to be in a satisfactory operating state and be able to return to a satisfactory operating state within 30 minutes following the occurrence of any credible contingency event.



For projects associated with station primary plant other than transformers, replacement is considered to be required as long as there is still a network need for the associated transmission lines or transformers or the station as a whole.

This assessment does not:

- Provide a comprehensive review of renewal expenditure for the AER's purposes.
- Attempt to provide advice or comment on the condition of AusNet Services' assets.
- Provide an assessment of project costs.
- Cover detailed options analysis.
- Identify new strategic land and easements.
- Cover AusNet Services' operational expenditure.
- Cover other capital expenditure such as information technology, metering, security, and telecommunications.



## 4. AEMO'S REVIEW OF ASSET REINVESTMENT WORKS

AEMO's review focuses on station and line projects that were not included in AusNet Services' asset renewal plan published with the 2015 VAPR. Table 1 summarises AEMO's consideration of possible reinvestment works identified as 'new projects' in AusNet Services' asset renewal plan.

**Table 1 AEMO's consideration of AusNet Services' proposed asset reinvestment works**

Asset grouping	Year	AusNet Services' project	Options considered by AusNet Services	AEMO assessment
Substation	2025	Keilor terminal station (KTS) A2, and A4 500/220 kV transformer replacement and retire A3 transformer subject to further studies	Integrated replacement and staged replacement. Replace with larger transformers.	Justified ongoing need for two 500/220 kV transformers at KTS. Possibly no need for replacement of either A2 or A3 transformer at KTS subject to further joint planning <sup>14</sup> investigation.
Substation	2025	KTS B4 220/66 kV transformer replacement	Integrated replacement and staged replacement. Replace with larger transformers.	KTS B4 transformer network need is justified. Potential for non-network alternatives for transformer replacement if cost-effective.
Substation	2024	Thomastown terminal station (TTS) B4 transformer and 66 kV Circuit Breaker (CB) replacement	Integrated replacement and staged replacement.	Possibly no need for replacement of TTS B4 220/66 kV transformer subject to further joint planning investigations.
Substation	2024	Kerang terminal station (KGTS) No.2 and No.3 220/66/22 kV transformer replacement	Integrated replacement and staged replacement.	Justified network need. Additional capacity may be needed. Potential for optimising capacity of new transformers if a non-network solution is cost-effective.
Substation	2023	Moorabool Terminal Station 500 kV and 220 kV CB replacement	Integrated replacement and staged replacement.	Ongoing need exists. No alternatives identified. Continue to monitor the need.
Substation	2025	Loy Yang power station (LYPS) 500 kV CB replacement Stage 1	Integrated replacement and staged replacement.	Ongoing need exists. No alternatives identified. Continue to monitor the need.
Substation	2025	Brooklyn terminal station (BLTS) 220 kV, 66 kV and 22 kV CB replacement	Integrated replacement and staged replacement.	Ongoing need exists. No alternatives identified. Continue to monitor the need.
Substation	2025	Rowville terminal station (ROTS) 220 kV CB replacement	Integrated replacement and staged replacement.	Ongoing need exists. No alternatives identified. Continue to monitor the need.
Substation	2025	Jeeralang terminal station (JLTS) 220 kV CB replacement	Integrated replacement and staged replacement.	Ongoing need exists. No alternatives identified. Continue to monitor the need.
Line	2017	Transmission ground wire replacement	No alternative options have been identified.	Justified network need.
Line	2017	Transmission line insulator replacement	No alternative options have been identified.	Justified network need.
Line	2020	Transmission line insulator replacement	Defer the work.	Ongoing need exists. No alternatives identified. Continue to monitor the need.
Line	2022	Transmission ground wire replacement	Defer the work.	Ongoing need exists. No alternatives identified. Continue to monitor the need.
Line	2025	Transmission line structure, conductor, and insulator replacement	Integrated replacement and staged replacement.	Ongoing need exists. No alternatives identified. Continue to monitor the need.

<sup>14</sup> Joint planning refers to planning undertaken by AEMO and AusNet Services and any relevant DNSPs.



## 5. FINDINGS OF AEMO'S REVIEW

AEMO's independent review found that AusNet Services' renewal plan is largely aligned with transmission network needs over the 10-year horizon. Of the 14 reinvestment projects reviewed by AEMO, AEMO found two possible opportunities to retire the plant without replacements, a possible opportunity for non-network services alternatives for transformer replacement, and a possible opportunity for non-network services to optimise capacity of replacement transformers:

- **Keilor 500/220 kV transformer replacement** – There is an opportunity to retire either the A2 or A3 500/220 kV transformer at Keilor terminal station, subject to a more detailed investigation. AusNet Services estimates that this option could reduce capital expenditure by approximately \$30 million. Following AEMO's review, AusNet Services reduced the number of planned transformer replacements at Keilor Terminal Station from three to two, and reduced the forecast capital expenditure by \$30 million. The final asset renewal plan published with the 2016 VAPR incorporates this change.
- **Thomastown 220/66 kV B4 transformer replacement** – There is an opportunity to retire the 220/66 kV B4 transformer at Thomastown terminal station, based on AEMO's connection point forecasts. AEMO estimates that this option could reduce capital expenditure by approximately \$15 million. Ongoing need for this transformer is jointly determined by DNSPs (Jemena and AusNet Electricity Services). AEMO considers it is appropriate for the DNSPs to continuously monitor the demand at Thomastown and identify the most economic option.
- **Keilor 220/66 kV B4 transformer replacement** – Ongoing need exists for replacement of Keilor B4 transformer. There is an opportunity for non-network alternatives for B4 transformer replacement if cost-effective.
- **Kerang 220/66/22 kV 1&2 transformer replacement** – Ongoing need exists for replacement of Kerang 220/66/22 kV 1&2 transformers, and additional transformer capacity may even be required. There is a potential for optimising capacity of new transformers if a non-network solution is cost-effective.

AEMO's detailed assessments of these projects are provided in Appendix A.

# APPENDIX A. DETAILED REVIEW OF AUSNET SERVICES' REINVESTMENT PROJECTS

## A.1 Substations

This section outlines each of the individual 'new project' reinvestment works that AusNet Services proposes at terminal stations.

### A.1.1 Keilor terminal station A2 & A4 500/220 kV transformers replacement

<b>Project</b>	Keilor terminal station (KTS) A2 & A4 500/220 kV transformers replacement and possible retirement of A3 500/220 kV transformer
<b>Year</b>	2025
<b>Credible alternatives</b>	Possibly no need for replacement of either A2 or A3 500/220 kV transformer subject to further joint planning investigation.
<b>Assessment objective</b>	Assess the transformer loadings to see if KTS A2, A3 and A4 500/220 kV transformers need to be replaced once retired.

#### Background

Figure 2 shows that Western metropolitan Melbourne is supplied by:

- The 500/220 kV A2, A3 and A4 transformers at Keilor terminal station (KTS).
- The GTS 1-3 and TTS 1-2 lines which are connected to other Melbourne and Geelong 500 / 220 kV transformation.
- Generation at Newport and Laverton North (connecting to the 220 kV loop supplied from KTS via lines WMTS 1-2, ATS and BLTS).

**Figure 2 Keilor terminal station connection configuration**

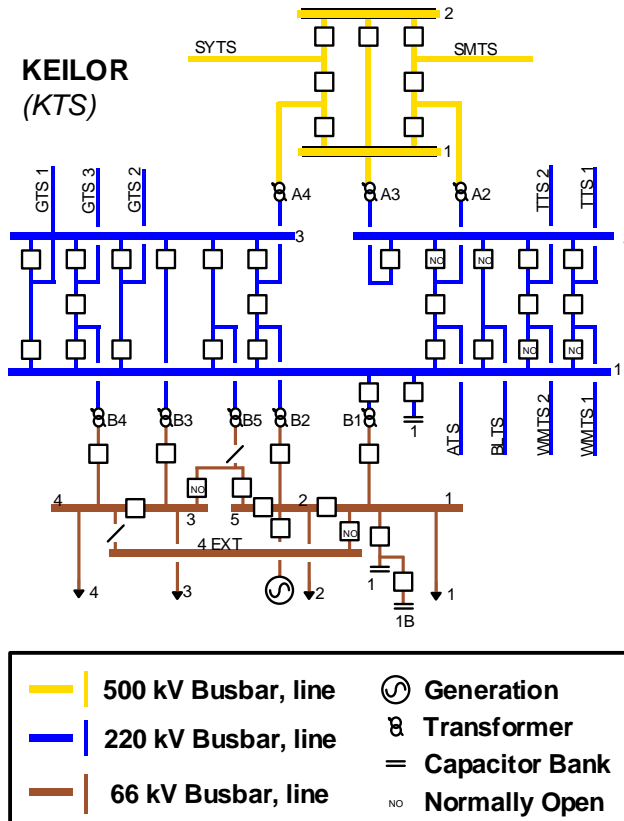

### AEMO connection point forecasts and projected transformer loadings

Figure 3 shows AEMO's 2015 summer and winter 10% POE and 50% POE coincident<sup>15</sup> maximum demand forecasts for western metropolitan Melbourne through to summer 2024–25.

**Figure 3 Western metro Melbourne coincident peak demand forecasts**

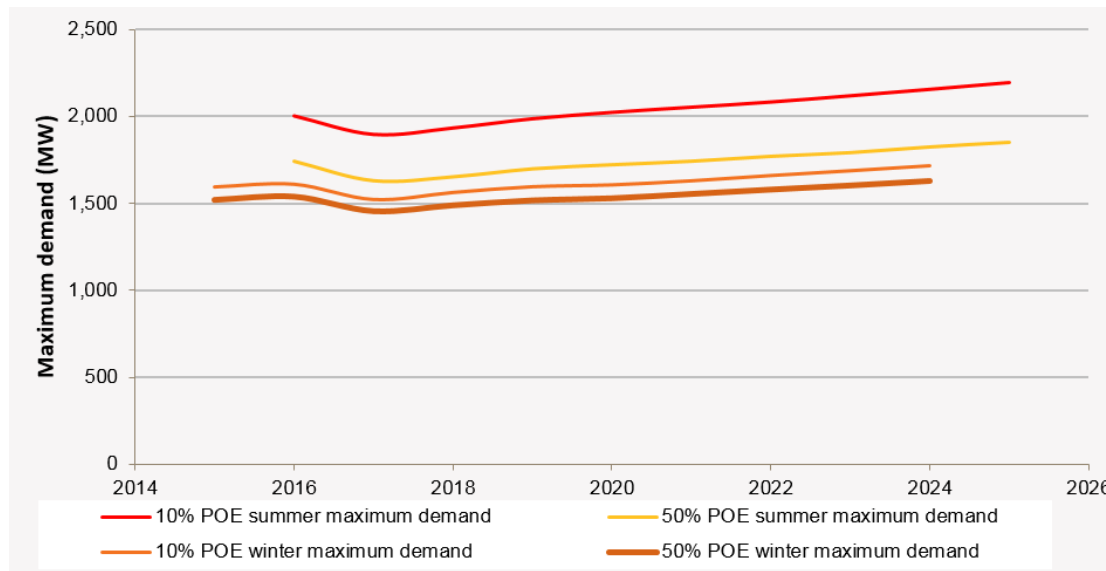

The forecast demand in Figure 3 will be supplied in part by the Keilor A2 and A4 transformers, as explained in the background section above. Assuming the Keilor A3 transformer is retired and not replaced, AEMO assessed projected peak loadings of the Keilor A2 and A4 transformers to meet these maximum demand projections. Three possible network configurations were considered:

- Configuration 1: Switch the Keilor–Thomastown 220 kV 1 & 2 circuits at KTS to bypass KTS A2 and A4 transformers and supply directly to West Melbourne terminal station (see Figure 4). This configuration reduces the loading on KTS A2 and A4 transformers.
- Configuration 2: Close the Keilor 220 kV bus ties, resulting in equal loading for the Keilor A2 and A4 transformers for the existing configuration. Minor works, such as to reduce station earth-grid impedances, may be required under this configuration.
- Configuration 3: Use the existing configuration, but without the A3 transformer.

Table 2 shows the projected peak loadings under the three network configurations assessed. The A3 transformer would only be required in future if the Keilor A2 and A4 transformer loadings under these configurations were in excess of the 750 MVA continuous and 1,000 MVA two hour rating of the transformers.<sup>16</sup>

<sup>15</sup> Coincident forecasts are the maximum demand forecasts of a connection point at the time system peak occurs. Non-coincident forecasts are the maximum demand forecasts of a connection point, regardless of when the system peak occurs.

<sup>16</sup> The ratings of the replaced transformers were assumed to be 750 MVA continuous and 1,000 MVA two hour.

**Figure 4 Keilor terminal station connection configuration – TTS-WMTS 1 & 2 switched to bypass KTS**

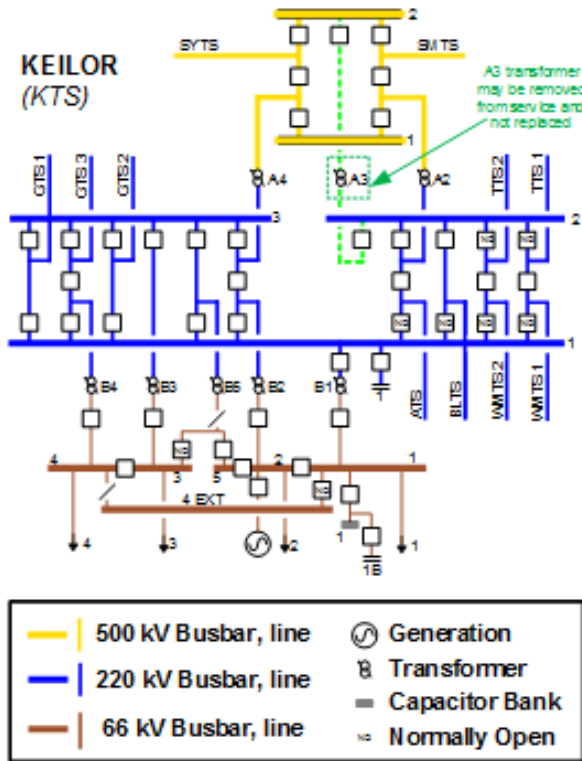

**AEMO’s assessment**

AEMO’s assessment showed that Keilor is expected to need only two 750 MVA transformers (A2 or A3, and A4) in 2025–26, based on loadings shown in Table 2. An alternative option could be to refurbish or rebuild some of the existing single phase transformers to extend their serviceable lives as two (A2 and A4) 750 MVA three phase banks, if feasible and economic.

**Table 2 Keilor A2 & A4 transformer loadings – 2024–25, Summer 10% POE<sup>a</sup>**

Configuration	N loading (MVA) <sup>b</sup>		N-1 loading (MVA) <sup>c</sup>	
	A2	A4	A2	A4
KTS A3 retired and not replaced. TTS-WMTS 1 & 2 circuits bypassing KTS formed by opening TTS 1 & 2 Number 2 bus CBs at KTS. ATS and BLTS circuits CBs to KTS No.2 bus side closed and KTS No.1 bus side CBs opened (see Figure 4). (Rating = 750 MVA each)	470	655	515	660
KTS A3 retired and not replaced. KTS 220 kV bus ties closed (Rating = 750 MVA each)	490	490	755	755
Existing configuration (except KTS A3 retired and not replaced) (Rating = 750 MVA each)	495	720	625	795

<sup>a</sup> Based on the 2016 VAPR analysis for the Gradual Evolution scenario.  
<sup>b</sup> Both transformers in service.  
<sup>c</sup> Only one transformer in service.

The loadings shown in Table 2 are for full generation output from Newport and Laverton North generation, considered appropriate for these peak demand conditions. If lower generation levels were to occur at peak demand, transformer requirements would need to be reassessed. Similarly, 2025

summer peak demand forecasts may vary in future years, affecting transformer loadings and requirements and necessitating reassessment.

After AEMO identified an opportunity to retire either the A2 or A3 500/220 kV transformer at Keilor, subject to a more detailed investigation, AusNet Services reduced the number of planned transformer replacements at Keilor from three to two. AusNet Services' final asset renewal plan (published with the 2016 VAPR) proposes to replace A2 and A4 transformers with two new 500/220 kV 750/1,000 MVA transformers and retire A3 transformer, subject to further studies.

AEMO and AusNet Services will jointly investigate the future need for 500/220kV transformers in the greater Melbourne and Geelong area as a whole to determine the most economic option. This investigation will involve sensitivity of KTS 500/220 kV transformer loadings to Newport and Laverton generation levels, peak demand forecasts, fault levels and fault ratings, and Greater Melbourne/Moorabool 500/220 kV transformer requirements.

**Conclusion**

AusNet Services' plan of only replacing two of the three 500/220kV transformers is considered reasonable.

More detailed joint planning studies may also be required to determine need for 500/220 kV transformation augmentation around 2025–26 in Melbourne's metropolitan area, and possibly at Moorabool. Findings from these studies may impact on the acceptability of retiring the KTS A3 transformer without replacement.

**A.1.2 Keilor terminal station 220/66 kV transformer replacement**

<b>Project</b>	<b>Keilor terminal station B4 220/66 kV transformer replacement</b>
<b>Year</b>	2025
<b>Credible alternatives</b>	Non-network alternatives for transformer replacement if cost-effective.
<b>Assessment objective</b>	Assess the transformer loadings to see if KTS B4 220/66 kV transformer needs to be replaced once retired.

**Background**

Keilor terminal station (KTS) has five 150 MVA 220/66 kV transformers that supply the north west of Greater Melbourne via Powercor's and Jemena's distribution networks. KTS 66 kV has two bus groups (East and West). At KTS, no more than three of the 220/66 kV transformers are connected to any one of the 66 kV bus groups due to fault level restrictions.

- The KTS B1, B2, and B5 transformers supply the KTS East 66 kV (125) bus group.
- The KTS B3 and B4 transformers supply the KTS West 66 kV (34) bus group (see Figure 2).

AusNet Services proposes to replace one of the existing five 220/66 kV transformers (B4) approaching the end of its serviceable life with a new 150 MVA transformer.

**AEMO connection point forecasts and projected transformer loadings**

This review considered whether KTS needs four, five, or six 150 MVA 220/66 kV transformers. The projected transformer loadings (based on 10% POE maximum demand forecasts) were compared with transformer thermal ratings.

Figures 5 and 6 show AEMO's 2015 10-year connection point forecasts for KTS East and KTS West 66 kV bus groups. The maximum demand forecasts project positive growth in summer peak demand at Keilor 66 kV from 2017–18.

These figures also show N and N-1 ratings of the transformers (with all transformers in service or one transformer out of service respectively) supplying these bus groups, under current arrangements:

- KTS East N transformer rating is for KTS B1, B2, and B5 transformers in service.
- KTS West N transformer rating is for KTS B3 and B4 transformers in service.

- For any one KTS 150 MVA transformer out of service, fault ratings and 66 kV switching allow reconfiguration, “replacing” the out of service transformer by operationally transferring a transformer between KTS East and KTS West 66 kV bus groups. However, under peak summer demand conditions:
  - Transferring a transformer from KTS West to KTS East, for outage of a transformer usually supplying KTS East, decreases total KTS demand supplied so is not implemented.
  - Transferring a transformer from KTS East to KTS West, for outage of a transformer usually supplying KTS West, increases total KTS demand supplied, so is implemented.

This practice results in the following N-1 transformer ratings:

- KTS East N-1 transformer rating is for two of KTS B1, B2, and B5 transformers in service and the other transformer out of service (Figure 5). As expected, this rating is approximately two-thirds of the KTS East N transformer rating.
- KTS West N-1 transformer rating is for either KTS B3 or KTS B4 transformer, and either KTS B1 or KTS B5 transformer, in service supplying the KTS West 66kV bus group (Figure 6). In other words, if one of the transformers supplying KTS West is out of service, supply is maintained by switching in one of the transformers normally supply KTS East. KTS West N and N-1 transformer ratings are therefore similar.

Figure 5 shows that AEMO’s 2015 10% POE summer demand connection point forecasts are about 50 MW lower than the KTS East transformation N summer rating at 42°C<sup>17</sup> in 2024–25 but higher than the corresponding N-1 transformation rating by about 115 MVA. This means that if a transformer is out of service during summer maximum demand periods, some load may not be supplied. The probability of a transformer outage is 0.217%<sup>18</sup> and the probability of this outage occurring during summer peak demand period is smaller still.

Figure 6 shows that AEMO’s 2015 10% POE summer demand connection point forecasts are about 60 MW lower than Keilor West transformation N and N-1 summer ratings at 42°C in summer 2024–25. Therefore, based on the current configuration and switching practices, KTS West summer maximum demand will be met even if one transformer is out of service.

If KTS B4 transformer was retired and not replaced, two configuration options were considered for the remaining four 150 MVA transformers, when all in service:

1. Three transformers supplying KTS East 66 kV buses, and one transformer supplying KTS West 66 kV buses.
2. Two transformers supplying KTS East 66 kV buses, and two transformers supplying KTS West 66 kV buses.

With all four transformers in service, Option 1 reflects the status quo for KTS East with N rating as shown in Figure 5. For KTS West, the N rating would reduce to about half the N rating in Figure 6, and so be lower than KTS West 50% and 10% POE summer maximum demands.

With all four transformers in service, Option 2 is the same as now exists for KTS West with N rating as shown in Figure 6. For KTS East, the N rating would reduce to the N-1 rating in Figure 5, and so be lower than KTS East 50% and 10% POE summer maximum demands from 2020.

With one of these four transformers out of service, three transformers would remain, allowing the 66 kV bus ties to close.<sup>19</sup> Figure 7 shows the resultant 50% and 10% POE summer maximum demands and N-1 (three transformer) rating. It also shows that, if the B4 transformer was removed and not replaced, AEMO’s 2015 overall 10% POE summer non-coincident connection point forecast at Keilor 66 kV is projected to exceed the N-1 summer rating by 210 MVA in summer 2024–25.

<sup>17</sup> This summer rating at 42°C is sourced from Victorian Electricity Distribution Business 2015 *Transmission Connection Planning Report*. <https://www.powercor.com.au/media/2248/transmission-connection-planning-report-2015.pdf>. Viewed 6 May 2016.

<sup>18</sup> Outage probability is sourced from Victorian Electricity Distribution Business 2015 *Transmission Connection Planning Report*. Refer note 20.

<sup>19</sup> KTS 66 kV fault ratings permit no more than three of the KTS 150 MVA transformers to be connected to KTS 66 kV buses directly connected to each other.

**Figure 5 Keilor terminal station East peak demand forecast**

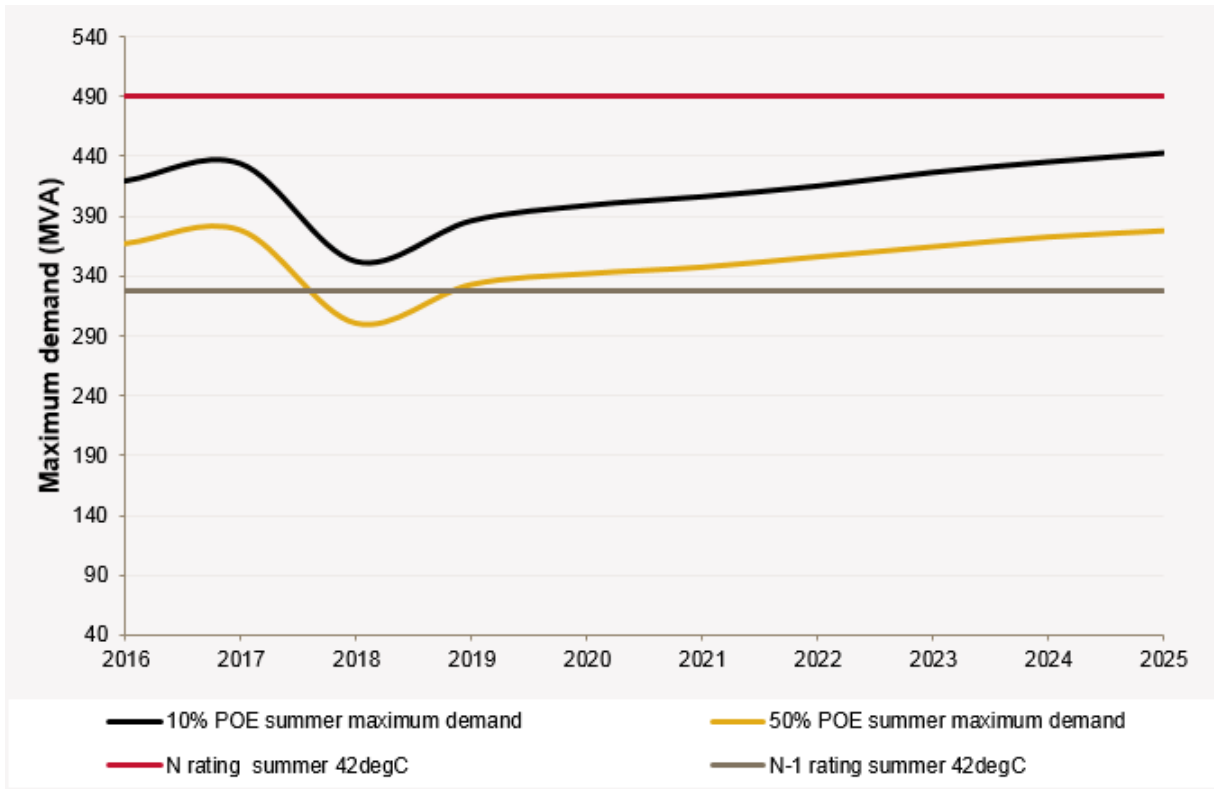

**Figure 6 Keilor terminal station West peak demand forecast**

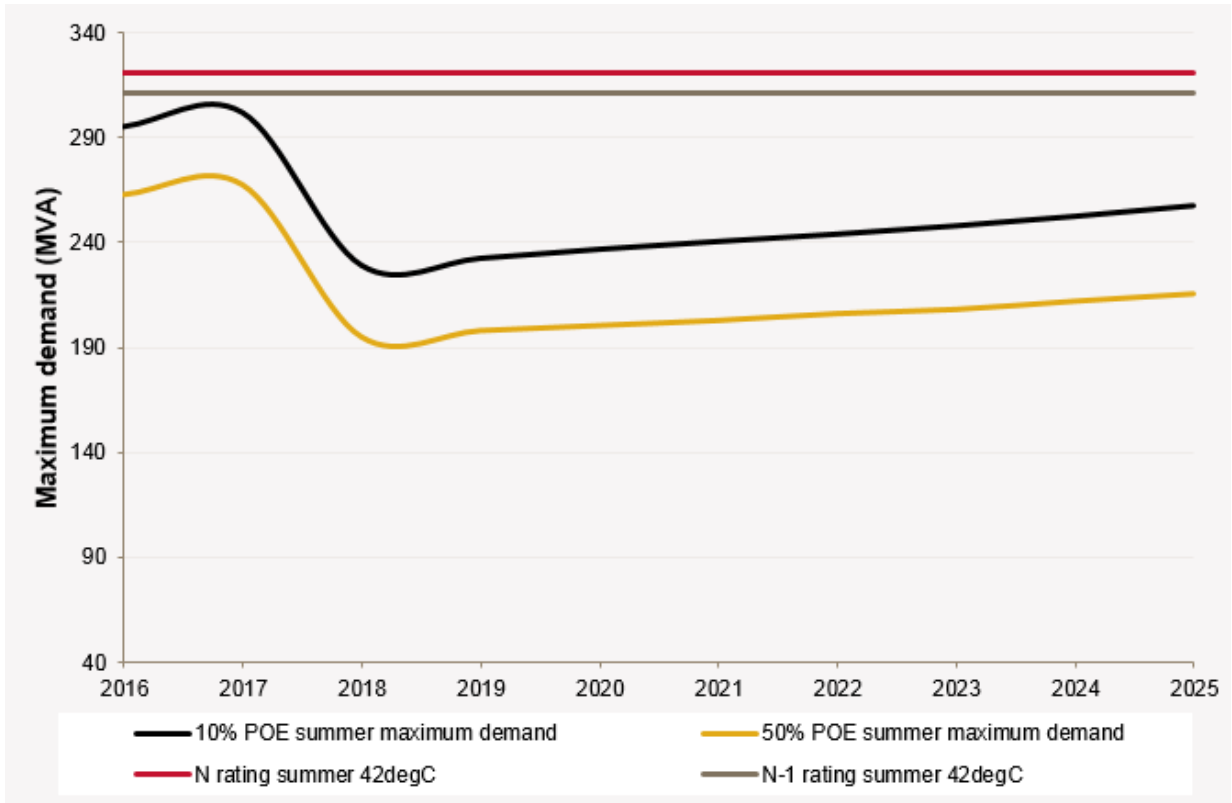

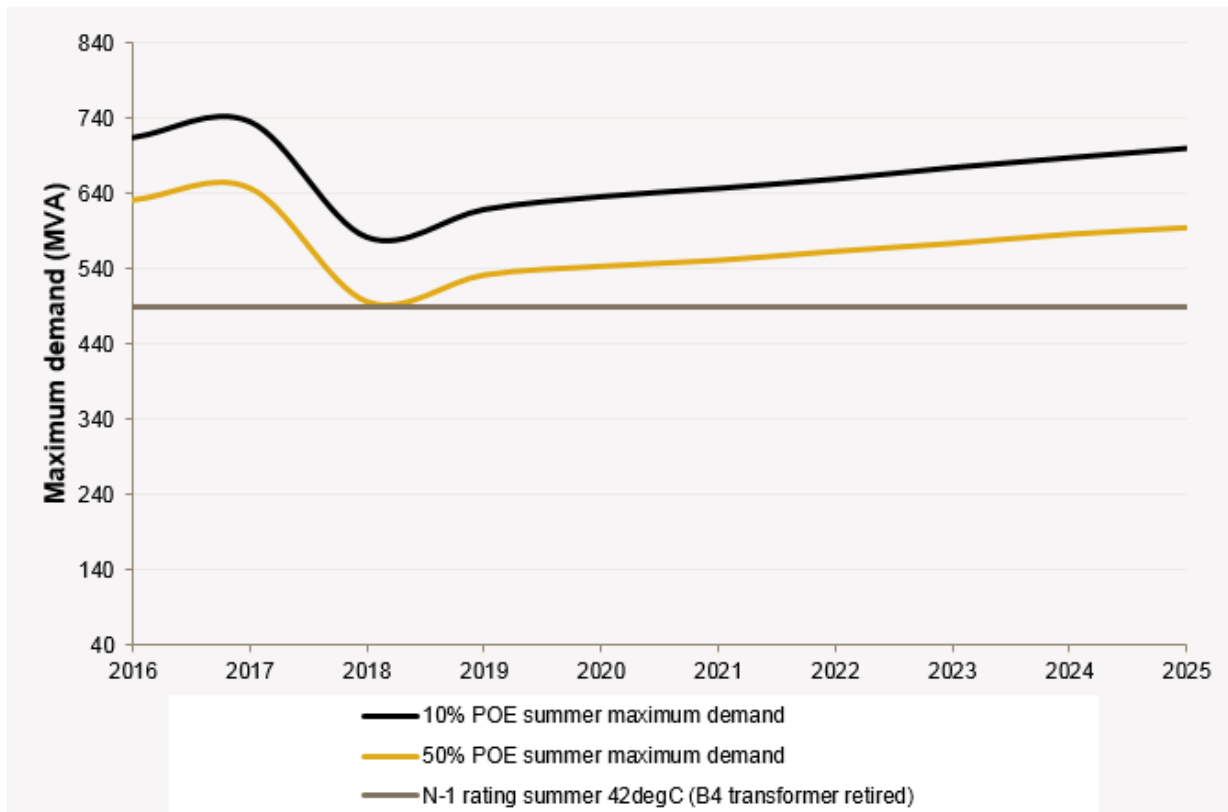

**Figure 7 Keilor terminal station peak demand forecast**

### AEMO's assessment

The existing five Keilor terminal station (KTS) 220/66 kV 150 MVA transformers cover the local supply for Powercor and Jemena customers supplied from KTS.

First, AEMO assessed whether five transformers are adequate, or six transformers may be justified. Based on the findings shown in Figures 5 and 6, AEMO concluded that the existing five 150 MVA KTS transformers are expected to be adequate to 2025, and that a sixth 150 MVA transformer at KTS is not expected to be justified then. In the event that one transformer is out of service at the time of KTS East summer maximum demand, there may be loss of load. However the cost of an additional transformer is not economically justified (based on comparable assessments by DNSPs) to cover this event due to its low probability of occurrence. Alternative network or non-network investments options (discussed below) may be more cost-effective.

Second, AEMO assessed whether four transformers (retiring B4 transformer without replacement) may be adequate, or five transformers (replacing B4 transformer) may be justified. AEMO's assessment is that four KTS transformers (retiring the B4 transformer without replacement) is not adequate, and five transformers (replacing the B4 transformer) are justified.

These assessments are sensitive to 2025 summer peak demand forecasts, which may vary in future years, affecting transformer loadings and requirements, necessitating reassessment.

AEMO did not identify any other transmission alternatives (such as reconfiguration of existing assets) for supplying local load, and therefore considers:

- There is an ongoing need for the asset.
- The existing configuration, voltage level, and transformer capacity is justified.

Replacement will result in an improved reliability at Keilor terminal station.



Future forecast maximum demand in excess of firm capacity at Keilor 66 kV terminal station may be addressed by operational or alternative strategies, such as:

- Load transfer schemes.
- Non-network solutions (for example, demand side management (DSM) initiatives, embedded generation, and/or battery storage).
- Reactive compensation for power factor improvement.
- Spare transformer to replace a failed unit.
- Operation of the Overload Shedding Scheme for Connection Assets (OSSCA).<sup>20</sup>

Possible replacement options in this case include:

- Like-for-like replacement with a new 150 MVA transformer.
- Refurbishing or rebuilding the existing transformers to extend their serviceable lives, if feasible and economic.
- Non-network solutions instead of replacement, if cost-effective.

**Conclusion**

AEMO’s assessment shows there is an ongoing need for the Keilor B4 transformer or for an equivalent non-network solution. This is based on 2025 summer peak demand forecasts, which may vary in future years, affecting transformer loadings and requirements, necessitating reassessment.

Possible options include like-for-like replacement, refurbishing or rebuilding the existing B4 transformer, or non-network solutions. AEMO considers it is appropriate for Powercor Australia, Jemena, and AusNet Services to carry out ongoing investigations into the network needs for the connection assets at Keilor before committing to this project.

**A.1.3 Thomastown terminal station B4 220/66 kV transformer replacement**

<b>Project</b>	<b>Thomastown terminal station (TTS) B4 220/66 kV transformer replacement</b>
<b>Year</b>	2024
<b>Credible alternatives</b>	Possibly no need for replacement of B4 220/66 kV transformer subject to further investigation.
<b>Assessment objective</b>	Assess the transformer loadings to see if TTS B4 220/66 kV transformer needs to be replaced once retired.

**Background**

Thomastown 66 kV terminal station (see Figure 8) provides supply to the north of Greater Melbourne. The Thomastown terminal station feeds the distribution networks of Jemena and AusNet Electricity Services via five 150 MVA 220/66 kV transformers.

AusNet Services proposes to replace one of the existing five 220/66 kV transformers (B4) approaching the end of its serviceable life with a new 150 MVA transformer.

<sup>20</sup> If the N-1 station rating is exceeded during an outage of single 220/66 kV transformer, the OSSCA will operate to protect the connection assets from overloading by reducing the loads in blocks to within safe operating limits.

**Figure 8 Thomastown terminal station (66 kV) connection configuration**

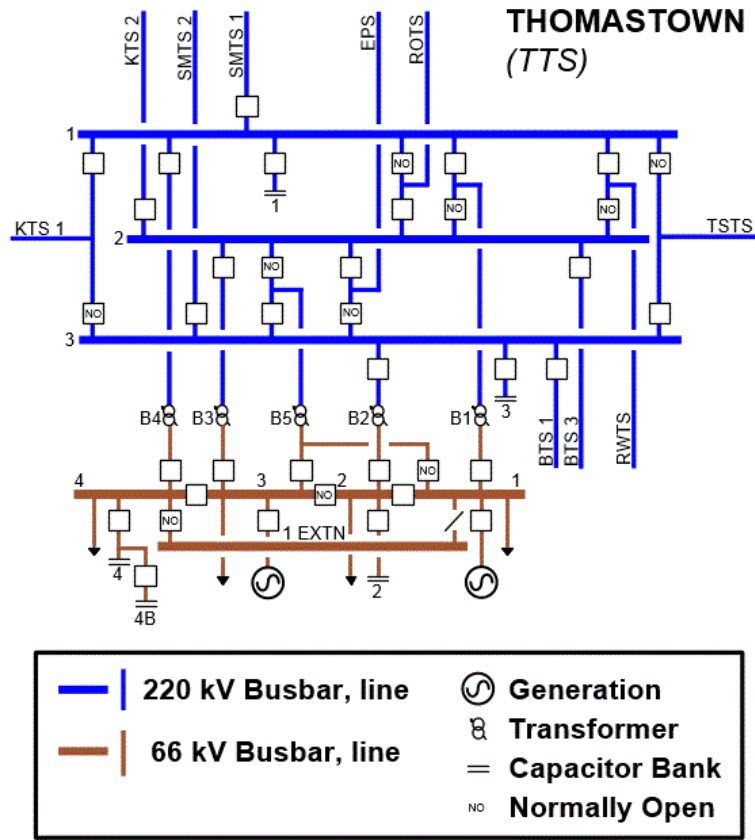

**AEMO connection point forecasts**

Figure 9 and Figure 10 below show AEMO’s 2015 10-year connection point forecasts for Thomastown 66 kV terminal station Bus 3&4 group, and for the entire Thomastown 66 kV terminal station, respectively.

Figure 10 shows that the forecast sum of non-coincident peak demand of the entire Thomastown 66 kV terminal station is projected to decline to 493 MVA (10% POE summer) and increase to 487 MVA (10% POE winter) by the end of the 10-year forecast period.

**Figure 9 Thomastown terminal station (66 kV) Bus34 group 10-year connection point forecast**

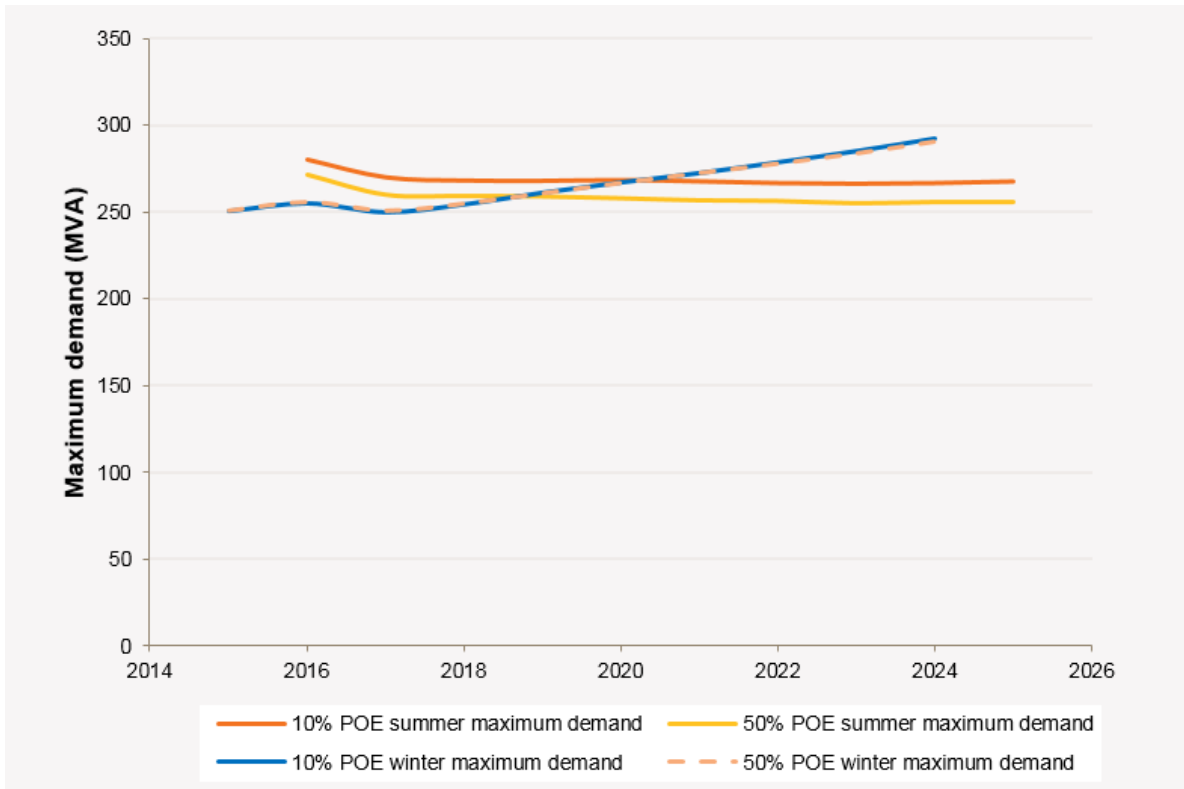

**Figure 10 Thomastown terminal station (66 kV) 10-year connection point forecast**

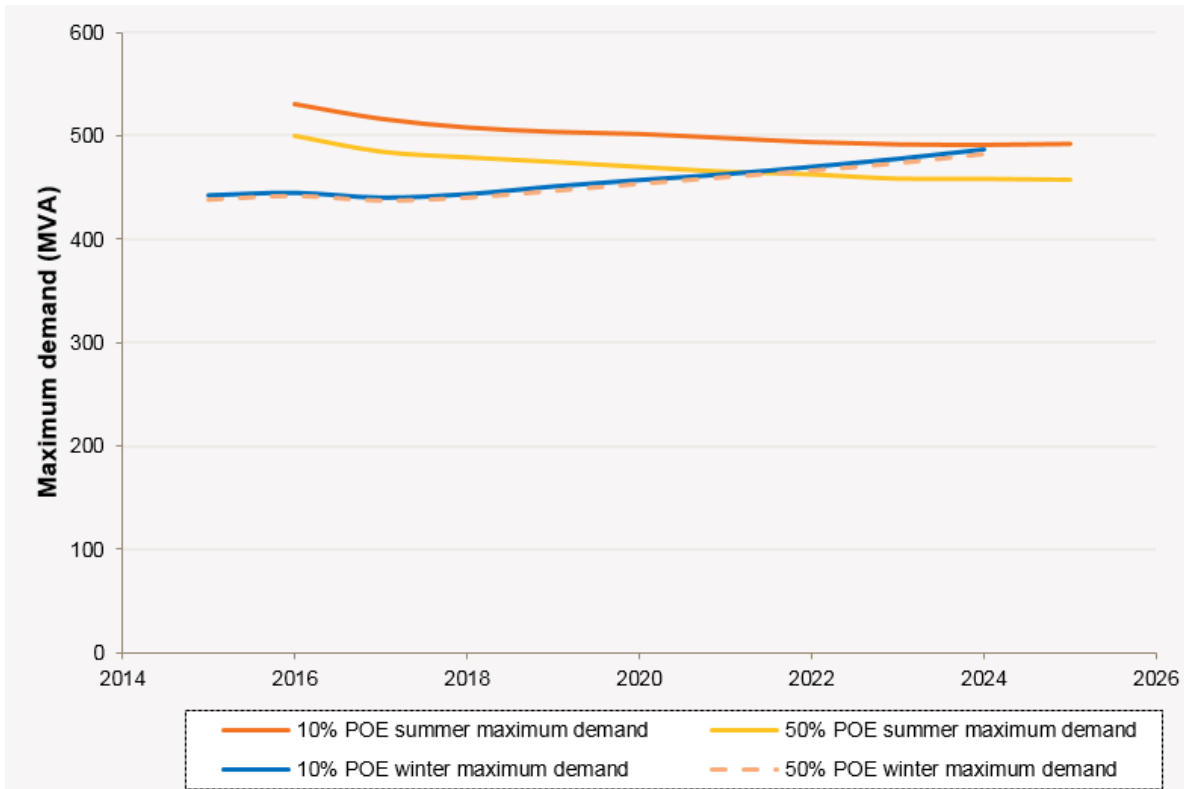

### AEMO's assessment

The existing five 220/66 kV 150 MVA transformers at Thomastown 66 kV terminal station (TTS) cover the local supply for Jemena's and AusNet Electricity Services' customers in the North Greater Melbourne region.

Currently, the five transformers are split into two separate groups (1&2 bus group, and 3&4 bus group), as shown in Figure 8, to limit the maximum prospective fault currents on the 66 kV buses within their respective switchgear ratings. An unplanned outage of any one of the five transformers at Thomastown will result in both the TTS 1&2 and TTS 3&4 bus groups comprising two transformers each.

The transformation requirement at Thomastown 66 kV is based on the following assumptions:

- B4 transformer is retired due to its asset condition.
- Four transformers will be in service during system normal with the split bus group in operation with two transformers in parallel at each bus group.
- The bus tie circuit breaker between Bus 2 and Bus 3 will be automatically closed following the contingency of losing one transformer.

For the above scenario, the summer firm capacity of Thomastown entire station is 495 MVA and winter firm capacity is 554 MVA. The N-1 loading of the TTS transformers is within summer and winter firm capacity, and the fault level at Thomastown 66 kV is within the fault level capability limit.

Based on AEMO's 2015 connection point forecasts, AEMO considers network need may not require the replacement of Thomastown B4 transformer and associated switchgears in the 10-year planning period, due to the forecast decline in summer maximum demand.

Under the DNSP's Terminal Station Demand Forecast (TSDF), which is significantly higher than AEMO's connection point forecasts, the replacement of Thomastown B4 transformer can be justified for the next 10 years. As the replacement of this transformer is proposed towards the end of 10-year outlook period, AEMO considers it is appropriate for the DNSPs (AusNet Electricity Services and Jemena) to continuously monitor the peak demand forecast at Thomastown and identify the most economic option.

Future forecast maximum demand in excess of firm capacity at Thomastown 66 kV terminal station may be addressed by operational or alternative strategies such as:

- Load transfer schemes.
- Non-network solutions (for example, DSM initiatives, embedded generation, and/or battery storage).
- Spare transformer to replace a failed unit.
- Operation of the Overload Shedding Scheme for Connection Assets (OSSCA).<sup>21</sup>

### Conclusion

Based on its 2015 connection point forecasts, AEMO considers that the replacement of Thomastown B4 transformer and associated switchgear may not be required in the next 10 years. AEMO considers it is appropriate for the DNSPs (AusNet Electricity Services and Jemena) and AusNet Services to carry out ongoing investigation on the need for the Thomastown B4 connection asset before committing to the replacement. As transformer need is sensitive to 2025 summer peak demand forecasts at Thomastown, which may vary in future years (affecting transformer loadings and requirements), the ongoing investigations should include reviews of these forecasts.

<sup>21</sup> If the N-1 station rating is exceeded during an outage of a single 220/66 kV transformer, the OSSCA will operate to protect the connection assets from overloading by reducing the loads in blocks to within safe operating limits.

### A.1.4 Kerang terminal station 220/66/22 kV transformer replacement

<b>Project</b>	<b>Kerang terminal station (KGTS) No.2 and No.3 220/66/22 kV transformers replacement</b>
<b>Year</b>	2024
<b>Credible alternatives</b>	Non-network alternatives for additional transformer capacity
<b>Assessment objective</b>	Assess the transformer loadings to see if KGTS No.2 and No.3 transformers need to be replaced once retired.

#### Background

Kerang 66 kV and 22 kV terminal station provides supply to Kerang and surrounding area. The Kerang terminal station feeds the distribution networks of Powercor, via three 35 MVA 235/66/22 kV transformers (see Figure 11).

AusNet Services proposes to replace two of the existing three 235/66/22 kV transformers (2 and 3) approaching the end of their serviceable lives with two new 35 MVA transformers.

**Figure 11 Kerang terminal station (66 kV & 22 kV) connection configuration**

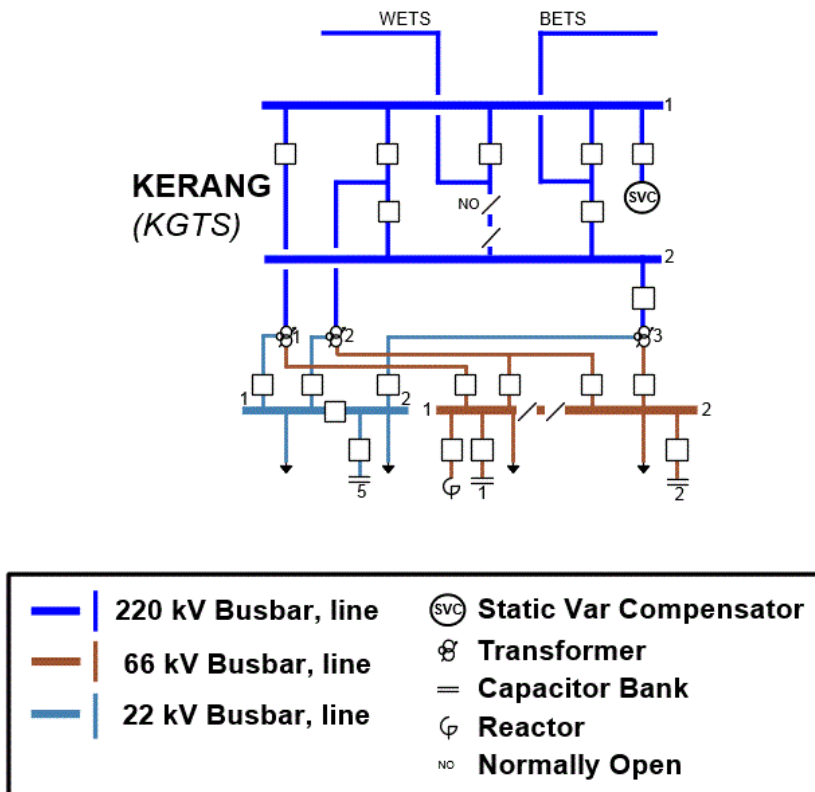

#### AEMO connection point forecasts

Figure 12 shows AEMO’s 2015 10-year connection point forecasts for Kerang 66 kV and 22 kV terminal station, which project high growth in summer peak demand at Kerang 66 kV over the forecast period. The sum of non-coincident summer peak demand at Kerang 66 kV and 22 kV is projected to reach 94 MVA (10% POE) by the end of the 10-year forecast period.

**Figure 12 Kerang terminal station 10-year connection point forecast**

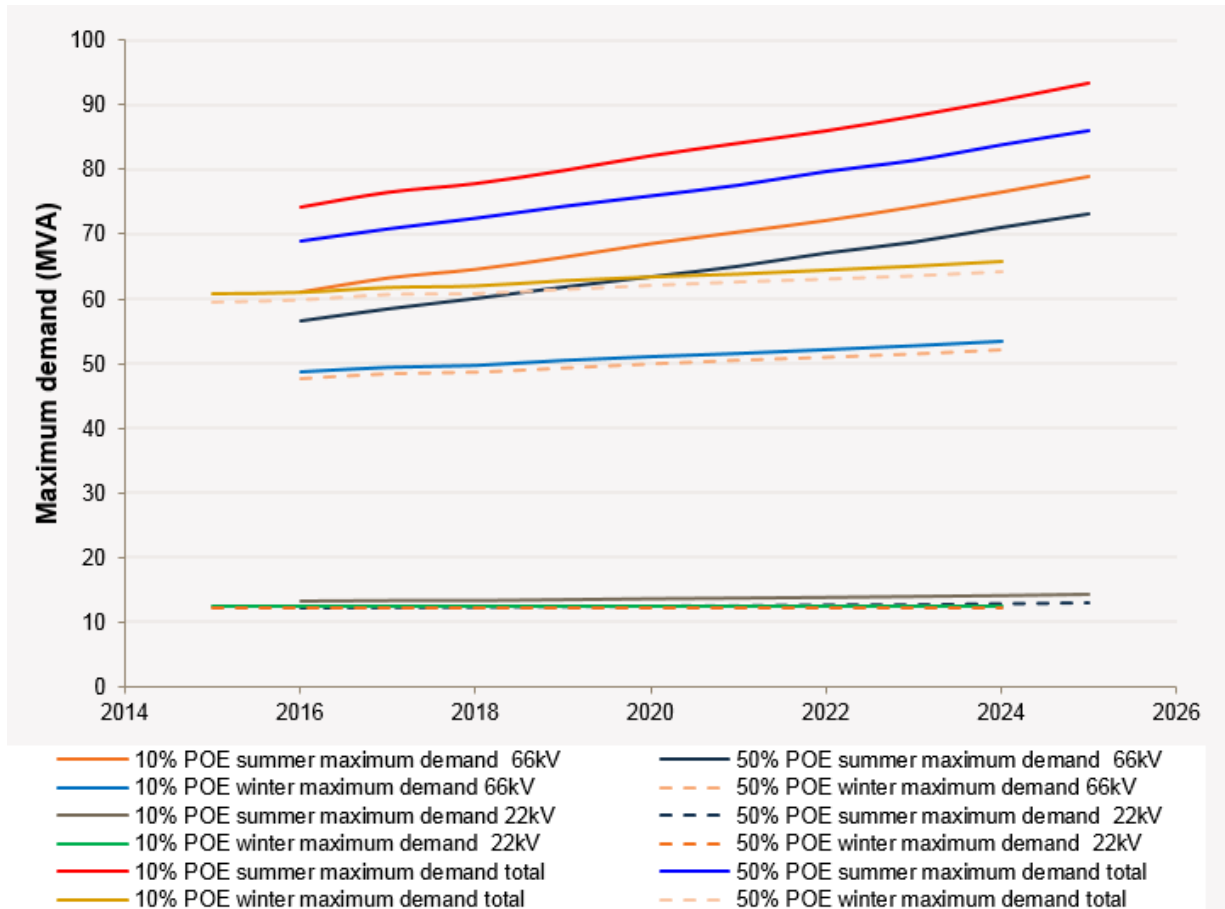

**AEMO’s assessment**

The existing three 235/66/22 kV 35 MVA transformers at Kerang 66 kV and 22 kV terminal station (KGTS) cover the local supply for Powercor customers in Kerang, Swan Hill, and Cohuna.

AEMO’s 2015 connection point forecasts show that 10% POE summer peak demand at Kerang 66 kV and 22 kV is projected to exceed the N-1 summer rating (88 MVA<sup>22</sup>) from 2023–24. Therefore, AEMO considers there is ongoing need for the existing 35 MVA 235/66/22 kV transformers.

Based on AEMO’s 2015 connection point forecasts, additional capacity may be needed to meet high demand growth at Kerang. AEMO considers transformer need is sensitive to 2024 summer peak demand forecasts at Kerang, which may vary in future years (affecting transformer loadings and requirements), and that therefore it is appropriate for AusNet Services and relevant DNSPs to review these demand forecasts and the associated need for additional capacity before committing to this project.

AEMO did not identify any other transmission alternatives (such as reconfiguration of existing assets) for supplying local load, and therefore considers:

- There is an ongoing need for the asset.
- Additional capacity may be required to the meet the future load forecasts.

<sup>22</sup> Victorian Electricity Distribution Business. 2015 Transmission Connection Planning Report. <https://www.powercor.com.au/media/2248/transmission-connection-planning-report-2015.pdf>. Viewed 6 May 2016.

Future forecast maximum demand in excess of N-1 rating at Kerang 66 kV and 22 kV terminal station may be addressed by operational or alternative strategies, such as:

- Load transfer schemes.
- Non-network solutions (for example, DSM initiatives, embedded generation, and/or battery storage).
- Spare transformer to replace a failed unit.
- Operation of the Overload Shedding Scheme for Connection Assets (OSSCA).<sup>23</sup>

### Possible replacement options

Possible replacement options in this case include:

- Like for like replacement with two new 35 MVA transformers.
- Replacement of the existing No. 2 and No. 3 transformers with two higher capacity transformers.
- There could also be potential for non-network solutions, if cost-effective.
- Refurbishment or rebuilding the existing transformers to extend their serviceable lives, if feasible and economic.

### Conclusion

AEMO's assessment shows there is an ongoing need for the Kerang No.2 and No.3 transformers, based on AEMO's 2015 connection point forecasts. Additional capacity may need to be considered to meet the forecast load growth in the Kerang area. There could be potential for optimising capacity of new transformers if a non-network solution is cost-effective. AEMO considers it is appropriate for Powercor Australia and AusNet Services to carry out ongoing investigations into the network needs for connection assets at Kerang before committing to this project. These investigations should include reviewing 2024 summer peak demand forecasts, as Kerang transformer needs are sensitive to these forecasts.

## A.1.5 Proposed major switchyard redevelopment projects

**Table 3 AusNet Services' proposed circuit breaker replacement projects**

Project	Year	Scope of work summary (transformer replacement is assessed separately)	Connection points	Status
Moorabool Terminal Station (MLTS) 500 kV & 220 kV circuit breaker replacements	2023	8 x 500 kV CBs 10 x 220 kV CBs	Shared Network	Planned
Loy Yang Power Station (LYPS) 500 kV circuit breaker replacements	2025	7 x 500 kV CBs	Loy Yang A, Loy Yang B, Valley Power stations & Shared Network	Planned
Rowville Terminal Station (ROTS) 220 kV circuit breaker replacements	2025	5 x 220 kV CBs	Shared Network	Planned
Brooklyn Terminal Station (BLTS) 220 kV circuit breaker replacements	2025	4 x 220 kV CBs	Shared Network	Planned
Jeeralang Terminal Station (JLTS) 220 kV circuit breaker replacements	2025	2 x 220 kV CBs	Shared Network	Planned

<sup>23</sup> If the N-1 station rating is exceeded during an outage of single 220/66 kV transformer, the OSSCA will operate to protect the connection assets from overloading by reducing the loads in blocks to within safe operating limits.



### Background

Table 3 shows five stations with two 500 kV and four 220 kV switchyards for which AusNet Services proposes major redevelopment. Each comprises multiple circuit breaker replacements. AusNet Services propose like for like replacement for each.

### Projected requirement

No owner of plant switched at Loy Yang Power Station (LYPS), itemised above, has declared an intention to disconnect. Similarly, no owner of Hazelwood (HWPS) or Jeeralang generation, utilising Jeeralang Terminal Station (JLTS) switching, has declared an intention to disconnect. Also, shared network loading forecasts indicate an ongoing need for shared network lines and station plant switched by the circuit breakers in Table 3.

There may be increasing commercial pressure for cessation of existing brown coal firing of generators connected to LYPS and HWPS, but cessation may result in new generation using these connections. There is a risk that replacement switchgear commissioned in 2025 may not be needed for a large part of its lifetime.

### AEMO’s assessment

Based on the information presently available, AEMO considers that there is ongoing need to switch the entities connected at the switchyards in Table 3.

AEMO notes that these replacements are proposed for seven to nine years in the future, and therefore considers that AusNet Services and AEMO should continue to monitor needs for this switching.

### Possible replacement options

No other options were identified.

### Conclusion

AEMO’s assessment shows there is an ongoing need to switch the entities connected at the switchyards in Table 3. Due to uncertainties around future generation and demand forecasts, AEMO considers it is appropriate for AusNet Services to carry out ongoing investigations into the network needs for the switchgear in Table 3 before committing to these projects.

## A.2 Transmission Lines

### A.2.1 Proposed transmission line component replacement projects

**Table 4 AusNet Services’ proposed transmission line component replacement projects**

Project	Year	Scope of work summary (transformer replacement is assessed separately)	Connection points	Status
Transmission ground wire replacement	2017	KTS-BLTS KTS-GTS 1, 3 ROTS-MTS SVTS-HTS 2 TTS-KTS 2 TTS-KTS 1	Shared Network	Committed
		CBTS-FTS66	Connection Asset	

Project	Year	Scope of work summary (transformer replacement is assessed separately)	Connection points	Status
Transmission line insulator replacement	2017	Insulators - 220 kV YPS-ROTS 5 YPS-ROTS 6 YPS-ROTS 7 YPS-ROTS 8 EPS-TTS 2L EPS-TTS 1R	Shared Network	Committed
Transmission line insulator replacement	2020	Insulators - 220 kV ROTS-TTS SMTS-TTS 1 MBTS-EPS 1 MBTS-EPS 2	Shared Network	Planned
Transmission ground wire replacement	2022	Ground wires - ROTS-RTS 1 ROTS-RTS 4 DDTS-SMTS2 HWPS-ROTS YPS-ROTS YPS-ROTS 5, 6	Shared Network	Planned
Transmission line structure, conductor and insulator replacement	2025	Towers - BETS-KGTS Insulators - 500 kV - MLTS-TRTS 1 MLTS-MOPS 1 330 kV - MSS-DDTS 1 220 kV - KTS-GTS 2 KTS-WMTS 1 KTS-WMTS 2 TTS-KTS 2N TTS-KTS 2S ROTS-MTS 3 ROTS-RTS 1 NPSD-FBTS FBTS-BLTS CBTS-TBTS 1 CBTS-TBTS 2	Shared Network	Planned
Transmission line insulator replacement	2025	66 kV - CBTS-FTS 1	Connection Asset	Planned

### Background

Table 4 shows proposed transmission line component replacement projects.

### Projected requirement

All lines proposed for component replacement are needed now. However, under modelled brown coal generation retirement scenarios there would not be a long-term need for some of these lines. There is a risk that replacement line work commissioned in 2025 may not be needed for a large part of its lifetime.



### **AEMO's assessment**

AEMO considers that the lines for which component replacements are proposed are needed now, and relies on AusNet Services' determination of the most economic means of safely keeping these lines in service now.

### **Possible replacement options**

No other options were identified.

### **Conclusion**

AEMO's assessment shows there is an ongoing need for the lines in Table 4, over at least the next ten years. Due to uncertainties around generation and demand forecasts, AEMO considers it is appropriate for AusNet Services to carry out ongoing investigations into the network needs for these lines before committing to these projects.

# MEASURES AND ABBREVIATIONS

## Units of measure

Abbreviation	Unit of measure
kV	Kilovolts
MW	Megawatts
MWh	Megawatt hours
MVA	Megavolt amperes
MVar	Megavolt amperes reactive

## Abbreviations

Abbreviation	Expanded name
AEMC	Australian Energy Market Commission
AER	Australian Energy Regulator
COAG	Council of Australian Governments
NCIPAP	Network Capability Incentive Parameter Action Plan
NTNDP	National Transmission Network Development Plan
NEM	National Electricity Market
NEO	National Electricity Objective
NEL	National Electricity Law
NTP	National Transmission Planner
TNSP	Transmission network service provider
USE	Unserved energy

## Victorian terminal and power stations

Abbreviation	Expanded name
<b>Terminal station</b>	
APD	Portland Aluminium Customer Substation
ATS	Altona Terminal Station
ARTS	Ararat Terminal Station
BATS	Ballarat Terminal Station
BLLY	Basslink Loy Yang Converter Station
BETS	Bendigo Terminal Station
BLTS	Brooklyn Terminal Station
BTS	Brunswick Terminal Station
CBTS	Cranbourne Terminal Station
DDTS	Dederang Terminal Station
DPTS	Deer Park Terminal Station
ELTS	Elaine Terminal Station
ERTS	East Rowville Terminal Station
FBTS	Fishermans Bend Terminal Station
FVTS	Fosterville Terminal Station
FTS	Frankston Terminal Station
GTS	Geelong Terminal Station

Abbreviation	Expanded name
GNTS	Glenrowan Terminal Station
HWTS	Hazelwood Terminal Station
HTS	Heatherton Terminal Station
HYTS	Heywood Terminal Station
HOTS	Horsham Terminal Station
JLA	Bluescope Steel Customer Substation (at Western Port)
JLTS	Jeeralang Terminal Station
KTS	Keilor Terminal Station
KGTS	Kerang Terminal Station
LY	Loy Yang Switching Station
MTS	Malvern Terminal Station
MLTS	Moorabool Terminal Station
MWTS	Morwell Terminal Station
MBTS	Mount Beauty Terminal Station
MLRC	Murraylink Converter Station (at Red Cliffs)
MSS	Murray Switching Station
PtH	Point Henry Customer Substation
RCTS	Red Cliffs Terminal Station
RTS	Richmond Terminal Station
RWTS	Ringwood Terminal Station
ROTS	Rowville Terminal Station
SHTS	Shepparton Terminal Station
SMTS	South Morang Terminal Station
SVTS	Springvale Terminal Station
SYTS	Sydenham Terminal Station
TATS	Tarneit Terminal Station
TRTS	Tarrone Terminal Station
TSTS	Templestowe Terminal Station
TGTS	Terang Terminal Station
TTS	Thomastown Terminal Station
TBTS	Tyabb Terminal Station
WBTS	Waubra Terminal Station
WETS	Wemen Terminal Station
WMTS	West Melbourne Terminal Station
WOTS	Wodonga Terminal Station
WDP	Wonthaggi Desalination Plant Customer Substation
<b>Power station</b>	
ARWF	Ararat Wind Farm
BDPS	Bairnsdale Power Station
BHWF	Bald Hills Wind Farm
BOPS	Bogong Power Station
CHWF	Challicum Hills Wind Farm
CLPS	Clover Power Station
DPS	Dartmouth Power Station
EPS	Eildon Power Station

Abbreviation	Expanded name
HPS	Hume Power Station
HWPS	Hazelwood Power Station
JLGS	Jeerelang Gas Station
LNGS	Laverton North Gas Station
LYPS	Loy Yang Power Station
MCWF	Macarthur Wind Farm
McKPS	McKay Creek Power Station
MPS	Morwell Power Station
MOPS	Mortlake Power Station
M1	Murray Power Station 1
M2	Murray Power Station 2
NPSD	Newport D Power Station
OWF	Oaklands Wind Farm
PTWF	Portland Wind Farm
SOPS	Somerton Power Station
VPGS (or LYGS)	Valley Power (or Loy Yang Gas) Station (also known as Valley Power Peaking Facility)
WBPS	Waubra Wind Farm
WKPS	West Kiewa Power Station
YPS	Yallourn Power Station
YWPS	Yallourn West Power Station
YWF	Yambuk Wind Farm

# GLOSSARY

This report uses many terms that have meanings defined in the National Electricity Rules. The Rules meanings are adopted unless otherwise specified.

Term	Definition
Annual planning report	An annual report providing forecasts of gas or electricity (or both) supply, capacity, and demand, and other planning information.
Augmentation	The process of upgrading the capacity or service potential of some part of a transmission (or a distribution) network.
Connection point	The point at which the transmission and distribution network meet.
Customer	A person who engages in the activity of purchasing electricity supplied through a transmission or distribution system to a connection point.
Demand-side participation (DSP)	The situation where customers vary their electricity consumption in response to a change in market conditions, such as the spot price.
Distribution network	A network that is not a transmission network.
Generation	The production of electrical power by converting another form of energy in a generating unit.
Load	A connection point or defined set of connection points at which electrical power is delivered to a person or to another network; or the amount of electrical power delivered at a defined instant at a connection point, or aggregated over a defined set of connection points.
Maximum demand	The highest amount of electrical power delivered, or forecast to be delivered, over a defined period (day, week, month, season, or year) either at a connection point, or simultaneously at a defined set of connection points.
National Electricity Law	The National Electricity Law (NEL) is a schedule to the National Electricity (South Australia) Act 1996, which is applied in other participating jurisdictions by application acts. The NEL sets out some of the key high-level elements of the electricity regulatory framework, such as the functions and powers of NEM institutions, including AEMO, the AEMC, and the AER.
National Electricity Market (NEM)	The wholesale exchange of electricity operated by AEMO under the National Electricity Rules (Rules).
National Electricity Rules (Rules)	The National Electricity Rules (Rules) describes the day-to-day operations of the NEM and the framework for network regulations. See also 'National Electricity Law'.
Network	The apparatus, equipment, plant and buildings used to convey, and control the conveyance of, electricity to customers (whether wholesale or retail) excluding any connection assets. In relation to a network service provider, a network owned, operated or controlled by that network service provider.
Network capability	The capability of the network or part of the network to transfer electricity from one location to another.
Non-network option	An option intended to relieve a limitation without modifying or installing network elements. Typically, non-network options involve demand-side participation (DSP) (including post contingent load relief) and new generation on the load side of the limitation.
N-1	A level of reliability where supply to customers is not affected when one network element is out of service.
Planning criteria	Criteria intended to enable the jurisdictional planning bodies (JPBs) to discharge their obligations under the Rules and relevant regional transmission planning standards.
Power system	The National Electricity Market's entire electricity infrastructure (including associated generation, transmission, and distribution networks) for the supply of electricity, operated as an integrated arrangement.
Power system security	The safe scheduling, operation, and control of the power system on a continuous basis in accordance with the principles set out in clause 4.2.6 (of the Rules).



Term	Definition
<b>Probability of exceedance (POE) maximum demand</b>	<p>The probability, as a percentage, that a maximum demand level will be met or exceeded (for example, due to weather conditions) in a particular period of time.</p> <p>For example, for a 10% POE maximum demand for any given season, there is a 10% probability that the corresponding 10% POE maximum demand forecast will be met or exceeded. This means that 10% POE projected maximum demand levels for a given season are expected to be met or exceeded, on average, 1 year in 10.</p>
<b>Primary plant</b>	<p>Equipment which is directly connected to the high voltage network. This includes circuit breakers, isolators, current transformers, voltage transformers, etc.</p>
<b>Reliability</b>	<p>The probability that plant, equipment, a system, or a device, will perform adequately for the period of time intended, under the operating conditions encountered. Also, the expression of a recognised degree of confidence in the certainty of an event or action occurring when expected.</p>
<b>Supply</b>	<p>The delivery of electricity.</p>
<b>Transmission network</b>	<p>A network within any National Electricity Market (NEM) participating jurisdiction operating at nominal voltages of 220 kV and above plus:</p> <p>(a) any part of a network operating at nominal voltages between 66 kV and 220 kV that operates in parallel to and provides support to the higher voltage transmission network,</p> <p>(b) any part of a network operating at nominal voltages between 66 kV and 220 kV that is not referred to in paragraph (a) but is deemed by the Australian Energy Regulator (AER) to be part of the transmission network.</p>
<b>Transmission system</b>	<p>A transmission network, together with the connection assets associated with the transmission network (such as transformers), which is connected to another transmission or distribution system.</p>
<b>Unserved energy (USE)</b>	<p>The amount of energy that cannot be supplied because there is insufficient generation capacity, demand-side participation (DSP), or network capability to meet demand.</p>